

Advantage PRO-MAX Pallet Truck with Scale (274720)

- Operation manual
- Parts book

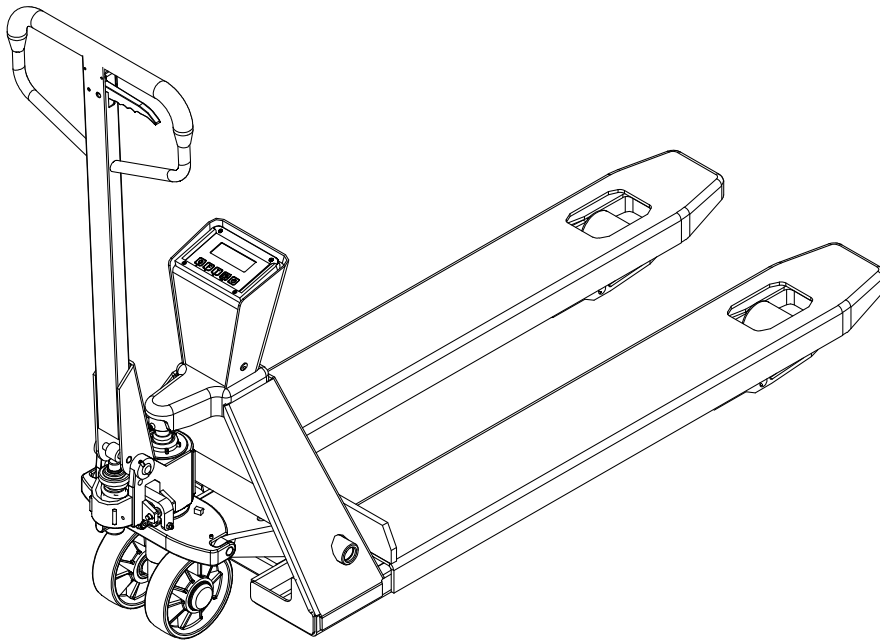

Thank you for selecting the Wesco Advantage PRO-MAX pallet truck with scale. Please read this operation manual carefully.

☆**Note:** The Advantage PRO-MAX hand pallet truck with scale is designed to weigh cargo in the warehouse. It is characterized by its stable lifting and lowering, easy operation and high reliability. The truck can be used as a material handling truck on the hard and flat floor indoor.

1. Technical parameter:

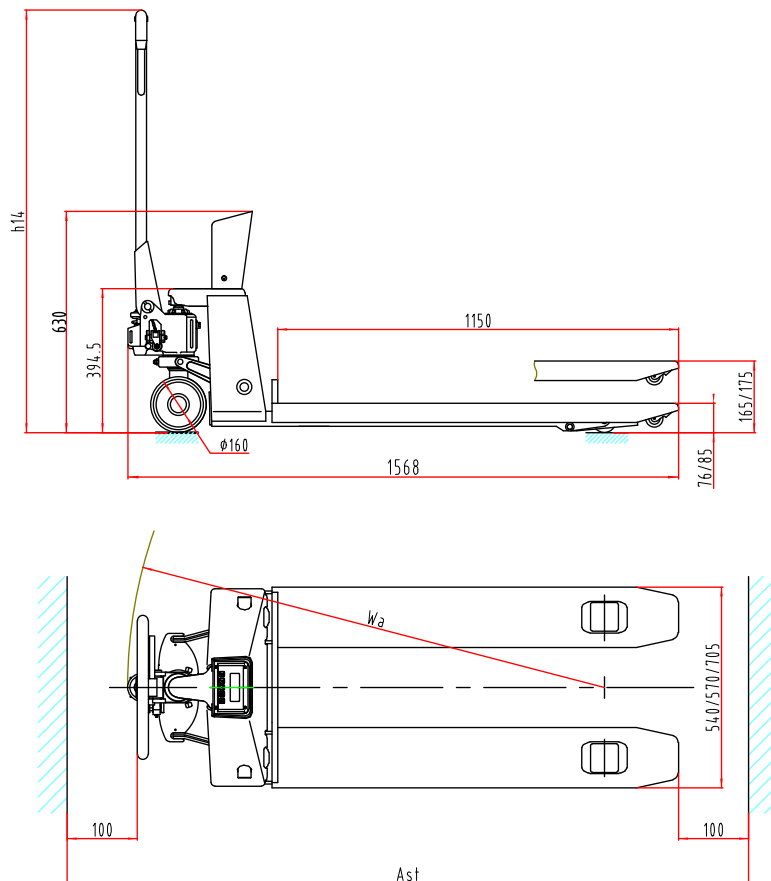

Rated capacity	kg	2000
Lowered fork height	mm	76/85
Wheel size, front	mm	165/175
Fork length	mm	1150
Fork overall width	mm	540/570/705
Wheel diameter	mm	Φ160
Fork wheel diameter	mm	Φ70
Power	V/Ah	4.8/4
Min. index value	kg	0.5
Weighing accuracy	kg	0.1%
Turning radius	mm	1368
Service weight	kg	115-130

2. Assembly

2.1 Handle assembly

2.1.1 Shown as Fig.1, remove elastic pin 1 from pin shaft 2, then pull out the pin shaft 2.

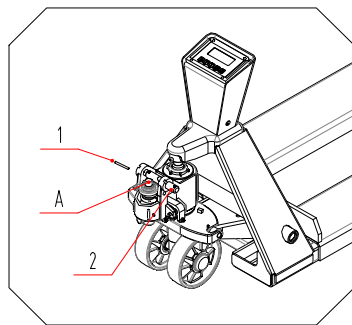

Fig. 1

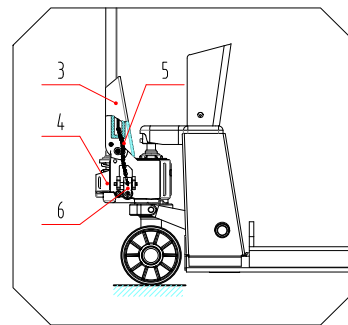

Fig. 2

- 2.1.2 Insert handle 3 into position A, and connect handle 3 and pump body 4 with pin shaft 2. Do not install the pin shaft 2 in the longitudinal direction to the bottom, leaving a gap for free rotation.
- 2.1.3 Turn the pin shaft 2 so that the axis of the large hole in the middle of the pin shaft is vertical, and pass the chain 5 on the handle through the hole in the middle of the pin shaft 2. See Fig 2.
- 2.1.4 Hang the screw nut at the end of chain 5 into the groove of lever plate 6. See Fig 2 and Fig 5.
- 2.1.5 Turn the pin 2 back to its original position, push it all the way to the bottom longitudinally, and then reset the elastic pin 1 through the pin 2.
- 2.1.6 As shown in Fig 3, pull the handle to the horizontal position, pull out the pin 7, and keep the pin 7 properly for use when replacing the handle next time.

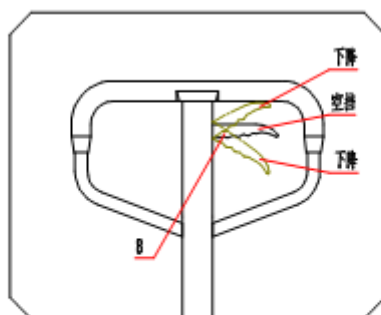

Fig. 4

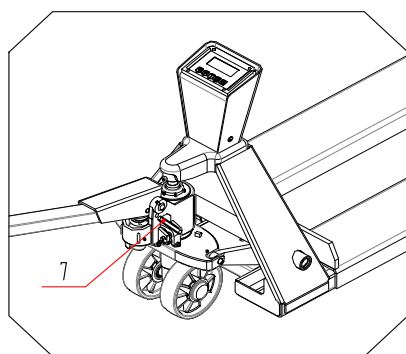

Fig. 3

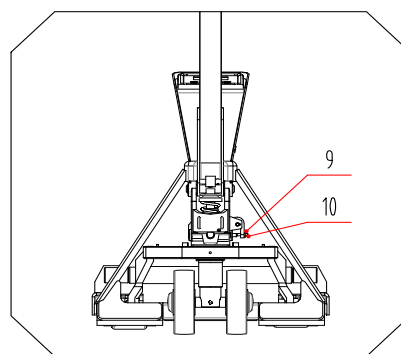

Fig. 5

- 2.1.7 Use the handle to shake it, and operate and control the different gears of knob 8 to see whether the car rises, neutral and falls normally. See Fig. 4.
- 2.1.8 The screw 9 in Fig. 5 is used to adjust the vehicle condition. When the truck body rises and then immediately descends, turn the screw 9 a little anticlockwise and try the truck again until it rises normally. If the truck body cannot be lowered after rising, turn the screw 9 clockwise a little and try again until it can be lowered normally. The outer hexagon nut 10 at the screw 9 plays a locking role. It should be loosened before adjustment and locked after adjustment.

2.2 Instrument assembly

- 2.2.1 See Fig. 6, place the scale frame in the direction and align it with the fixing hole.
- 2.2.2 Fix the screw 11 to the instrument box assembly as shown in Fig. 6.
- 2.2.3 Connect the sensor harness.

2.3 Instrument charge

- 2.3.1 The charging interface is located on the right side of the instrument box (12 of Fig. 6), which can be charged by connecting with the external charging line.

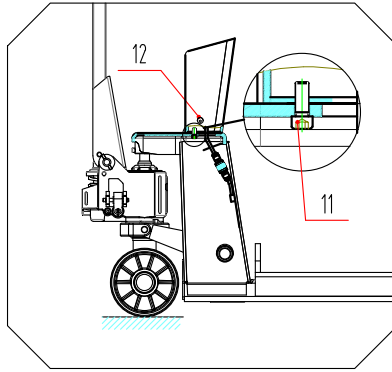

Fig. 6

3. Basic functions

3.1 Major parameters of the instrument





Accuracy level:	Meet level III standard
Display:	LCD display
Keyboard:	5 function keys
Zero Range:	±10% maximum capacity
Manual zero range:	±2% maximum capacity
Working temperature:	-10~+40°C
Storage temperature:	-20~+60°C

3.2 Battery

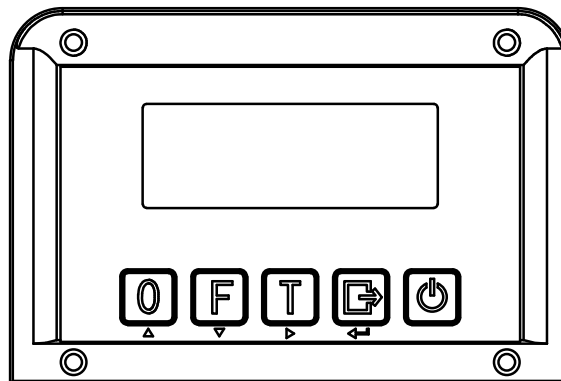
The instrument adopts 4.8V 4Ah lithium battery, which can be used continuously for more than 60 hours, stand-by for up to 300 hours and charge only for 5 hours.

3.3 Key description



Icon	Name	Description
	Zero key	Clear the instrument within the allowable range of zero setting; if it is out of the range of zero setting, it is the peeling action, and the weight of the article is the tare peeling, indicating the net weight zero.
	Unit key	Switch units between KG and LB.
	Accumulation key	1. Cumulative operation 2. View cumulative sum with function key
	Function key	1. Together with the ON/OFF key to enter calibration. 2. Long press to act printing. 3. View cumulative sum with accumulation key
	ON/OFF key	When the meter is turned off, press and hold for about 3 seconds to turn on; when it is turned on, press and hold for about 3 seconds to turn off.

3.4 Function description

3.4.1 ON/OFF



Press  3 seconds to conduct self-test; after finish self-testing, the instrument shows current weight.

Press  3 seconds to shut the instrument

3.4.2 Zero setting

When the zero setting range is exceeded, press  to show net weight. When the instrument is in dynamic display, that is, when the stable light is not on, the function de energized.

3.4.3 Extended display

Press  and  when the data is stable. The scale of instrument display is increased by 10 times automatically, and the user can get more accurate weight display. After 3 seconds, it will automatically return to the normal weighing state.

3.4.4 Print

When the data is stable, Press  1second, Output current weight from serial port.

3.4.4 Accumulation

Accumulate multiple weighing data.

3.4.4.1How to accumulate

When the data is zero, put the load on the scale, when the data becomes stable, press





to enter accumulation, it displays n001, then displays weight of current



load. Remove the load, returning to zero, put on the load, press again when data is stable, the instrument displays 002, then displays current weight. In this way, 999 cycles can be accumulated.

3.4.4.2 View cumulative sum and weight



Press first and then press to  without releasing  to display n***, the total cumulative times, and then the cumulative sum. The cumulative total is displayed as 8-bit data: the display format is to display the 4 bits of the high bit first, then the 4 bits of the low bit. For example, the 4 bits of the high bit are 0012, and the 4 bits of the low bit are 34.56. At this time, the total cumulative weight is 1234.56kg.

3.4.4.3 Exit accumulation

When the cumulative sum status meter displays low 4 bits, long press , the instrument shows "CLR n" meaning not clearing the cumulative sum record; press and

exit the cumulative function; to clear the cumulative sum, press  when it

shows " CLR n" to change to "CLR Y" . Press  to clear the cumulative sum record at the same time exit the cumulative function.

4. Loading method and rated load

4.1 the loading method is that the center of gravity of the heavy object is in the center of the fork, and the rated load must be reduced in case of off load. The rated load capacity is shown on the label.

4.2 as shown in Fig. four, when the goods need to be weighed or moved, the handle 8 should be in the down position to make the fork drop to the proper position, insert the fork into the tray, and then make the handle 8 in the up position, and shake the handle to make the fork rise.

4.3 when moving the loading keep the knob 8 in the neutral position.

5 Hydraulic oil

5.1 The hydraulic oil required for the oil pump is about 250ml (or 0.25kg). According to ISO oil standard, when the ambient temperature is - 5 ~ 40 °C, 32 # 3 oil is used, and when the ambient temperature is - 35 ~ 5 °C, low temperature working oil is used.

5.2 Disposal of waste oil: it shall be handled properly in accordance with relevant laws and shall not be dumped casually.

6. Common problems and troubleshooting of the instrument

6.1 Common problems and troubleshooting

No	Fault	Cause analysis	Trouble shooting
1	Display UUUUU	<ol style="list-style-type: none">1. the current weight value is greater than the overload range of the maximum scale2. the signal wire of the sensor is not connected or wrongly connected3. sensor failure	<ol style="list-style-type: none">1. Reduce the scale.2. Check the sensor wiring.3. Check the sensor: it can measure the input resistance and output resistance of the sensor to judge whether it is good or not.
2	Display nnnnn	<ol style="list-style-type: none">1. scale body debugging is not good2. wrong connection of sensor signal wire3. sensor failure	<ol style="list-style-type: none">1. Check whether the scale platform is countered or collided.2. Check the sensor wiring.3. Check the sensor: it can measure the input resistance and output resistance of the sensor to judge whether it is good or not.
3	ERR1	During calibration, the added weight is not entered or the entered weight exceeds the maximum scale.	Enter the weight correctly.
4	ERR2	During the calibration process, too few weights are added.	The added weight shall be at least 10% of the maximum weight, and 60% - 80% of the maximum weight is recommended.
5	ERR3	During calibration, the input signal is a negative value.	<ol style="list-style-type: none">1. Check whether the wiring is correct;2. Check whether the sensor is damaged;3. Recalibrate and replace the main board if there is still an error.
6	ERR4	During calibration, the signal is not stable.	After confirming that the added weight and platform are stable, start to calibrate.

7	ERR5	EEPROM check error.	Replace PCB board.
8	ERR6	Out of zero range.	Remove the objects on the scale before operation.
9	ERRAD	Ad chip failure	Replace the motherboard.

6.2 Common problems and troubleshooting

No	Fault	Cause analysis	Elimination method
1	Insufficient lift	Insufficient hydraulic oil	Add proper filtered working oil
2	Return not in place	<ol style="list-style-type: none"> 1. Too much hydraulic oil filling 2. The rotating part is deformed and stuck 3. The plunger and guide rod screw sleeve are stuck. 	<ol style="list-style-type: none"> 1. Remove proper working oil 2. Replace parts
3	Fork does not drop after rising	<ol style="list-style-type: none"> 1. The unloading device is abnormal 2. Deformation and damage of parts 	<ol style="list-style-type: none"> 1. Readjust the unloading device. See 4.2 2. Replace the deformed and damaged parts
4	Hydraulic oil leakage	<ol style="list-style-type: none"> 1. Oil seal failure 2. The surface of some parts is slightly damaged or worn 3. Loose connection 	<ol style="list-style-type: none"> 1. Replace the oil seal 2. Replace the damaged parts 3. Retighten the loose parts
5	Fork does not rise	<ol style="list-style-type: none"> 1. The working oil viscosity is too large, or the working oil is not injected 2. Impurities in oil 3. The unloading device is abnormal 	<ol style="list-style-type: none"> 1. Replace oil 2. Remove the impurities in the oil circuit and renew the working oil 3. Readjust the unloading device, see 4.2
6	When the handle is shaken, the fork rises and then immediately descends. The handle has a large rebound phenomenon, or the fork rises and then descends obviously.	Valve stuck by sundries	Open the valve, take out and clean the parts, and then replace them

7. Working environment

This scale truck is suitable for general industrial and commercial environment. The working temperature is required to be within the range of $-10\text{ }^{\circ}\text{C} \sim +40\text{ }^{\circ}\text{C}$, the relative humidity is $\leq 90\%$ RH, and the road surface is required to be flat. It is not suitable for places with explosive substances.

8. Warning

- 8.1 Read the instructions before operating the scale truck, and master the scale performance.
- 8.2 When the truck is controlled to descend by the pinch hand, it shall be raised a little bit first to make the truck body descend slowly. It is not allowed to pull the pinch hand violently. The rapid descent will cause damage to the truck and goods of the electronic scale!
- 8.3 Do not shake the handle in the form of rapidity and high frequency!
- 8.4 Do not load the heavy object on the fork rapidly!
- 8.5 Do not overload use, overload will not work properly!
- 8.6 The center of gravity of the goods shall be in the middle of the two forks, and the off loaded goods will make the electronic scale carrier lose balance!
- 8.7 Do not use this scale truck for non-pallet goods!
- 8.8 Do not leave the goods on the fork for a long time!
- 8.9 When the scale truck is not working, keep the fork in the lowest position and turn off the power!
- 8.10 It is strictly prohibited to carry people, or walk on the fork! Do not put any part of the body under heavy objects!
- 8.11 It shall be used on flat and hard ground. Do not use on sloping ground!
- 8.12 Do not expose the truck to the sun or rain!
- 8.13 Do not operate unspecified parts!
- 8.14 Do not attempt to repair without training!
- 8.15 If the battery is damaged or the use is over, it must be sent to the recycling station and treatment station. Do not throw it around!
- 8.16 This scale is not suitable for trade settlement.

9. Maintenance

- 9.1 Carry out routine inspection every day, eliminate abnormal phenomena in time, and do not use the car with faults, so as to extend the service life. Add lubricating oil to each rotating joint every three months, pay special attention to the wheel and shaft not to be entangled by yarn and other debris, and keep all wheels rotating easily.
- 9.2 To ensure clear display and service life of the instrument, the instrument should not be used in direct sunlight.
- 9.3 Instruments and sensors shall be reliably connected, and the system shall be well grounded and far away from electric field and magnetic field.
- 9.4 Do not use the instrument outdoors in thunderstorm, and it is better to turn off the power supply of the instrument.
- 9.5 When plugging in or out any interface connector of the instrument, please turn off the power supply first.
- 9.6 It should not be used in places with serious dust and vibration, and avoid using in humid environment.
- 9.7 Use soft cotton cloth and neutral detergent to scrub the instrument shell to keep the instrument clean.
- 9.8 There is a battery icon in the lower right corner of the instrument. If the battery icon flashes when the battery voltage is too low, please plug in the charger in time to charge the battery. The battery bar icon of the meter flashes when charging.
- 9.9 Take out the dry battery when it is not used for a long time.

10. Packing list

Packing list

Consignee:
Contact no.:

Ex-factory No.:
Ex-factory date:

No.	Product	Qty	N.W.(kg)	Dimension (L×W×H)	Remark
1	Hand pallet truck with scale	1			The whole truck
2	Accessory bag	1			Technical documents, accessories and spare parts are included

Note:1. The following documents are in the technical document bag

1. Operation manual 1 copy
2. Parts book 1 copy
3. Qualified certification 1 copy
4. Packing list 1copy

2. Accessories and spare parts

No.	Name	Use position	Specification	Qty	Remark
1	Elastic pin	Handle	5x35	1 个	

Consignor: