

276061

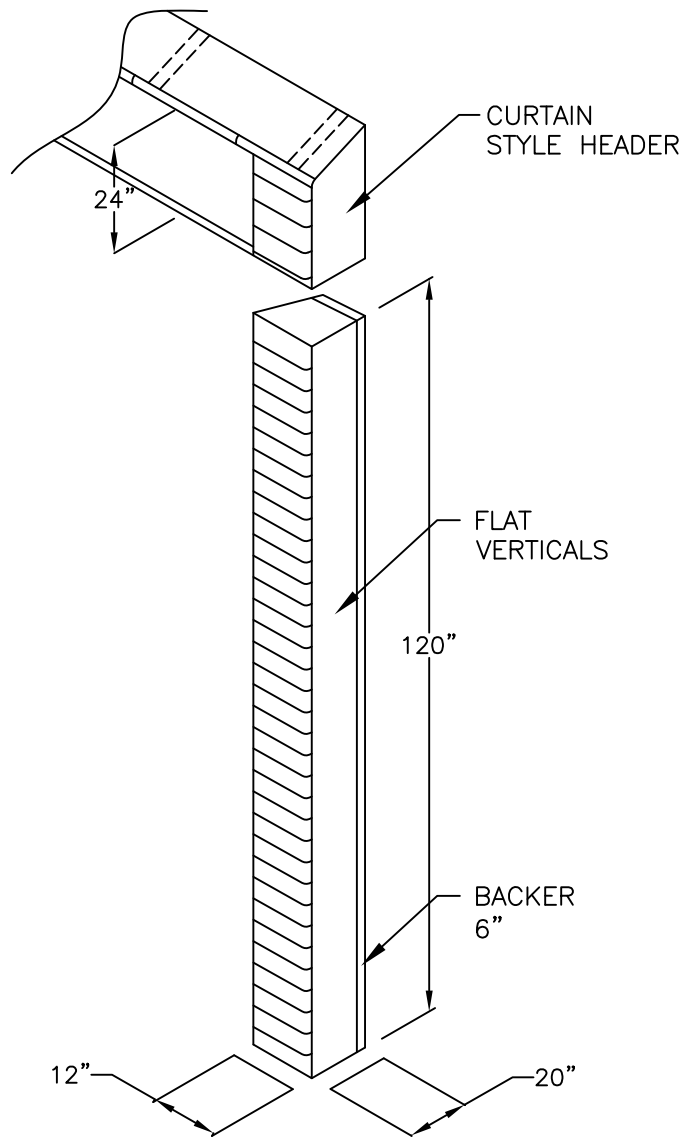

REPLACEMENT PARTS			
ITEM	PART NO.	DESCRIPTION	QTY.
1	276310	VERTICAL FOAM PAD, LEFT (10'H 20"P)	1
2	276311	VERTICAL FOAM PAD, RIGHT (10'H 20"P)	1
3	276315	HORIZONTAL FOAM PAD (10'H 20"P)	1
4	276319	HARDWARE KIT	1
5	276318	WEAR PLEATS (10'H)	2

**Wesco Dock Seals**

- 40 oz high-tear-abrasion-resistant fabric.
- Double lock stitched seams.
- Kiln dried superior grade back lumber.
- 99% Memory Foam core for extended life.
- Fixed head pad provides maximum seal.
- Condensation drainage system.
- Full height yellow guide strips.
- Galvanized mounting hardware included.

**Specs**

Door Width: 96" (8')  
 Door Height: 120" (10')  
 Projection: 20"  
 Weight: 300 lbs

THIS DRAWING IN ALL PARTICULARS IS WESCO INDUSTRIAL PRODUCTS, LLC PROPERTY. ALL RIGHTS OF DESIGN, INVENTION OR USE OF ARE RESERVED.

PRINT ISSUED

JUN-26-2020

WESCO MANUFACTURING  
ENGINEERING DEPARTMENT

BS

APP

06-26-20  
RELEASED FOR  
PRODUCTION

ECN & DATE

REVISIONS

A

REV.

**WESCO INDUSTRIAL PRODUCTS, LLC**

NORTH WALES

PENNA. 19454

PART NAME

DS-96120-20-P  
DOCK SEAL

DRAWN:

CHECKED:

APP. ENGR.

SCALE:

TOLERANCE UNLESS OTHERWISE SPECIFIED

FRACTION 3 PLACE DECIMAL 2 PLACE DECIMAL

± 1/64 ± .005 ± .01

ANGULAR ± 1-1/2° SHEET 1 OF 1

BREAK ALL SHARP EDGES AND REMOVE ALL BURRS

**A-276061**

REV

A