

210239

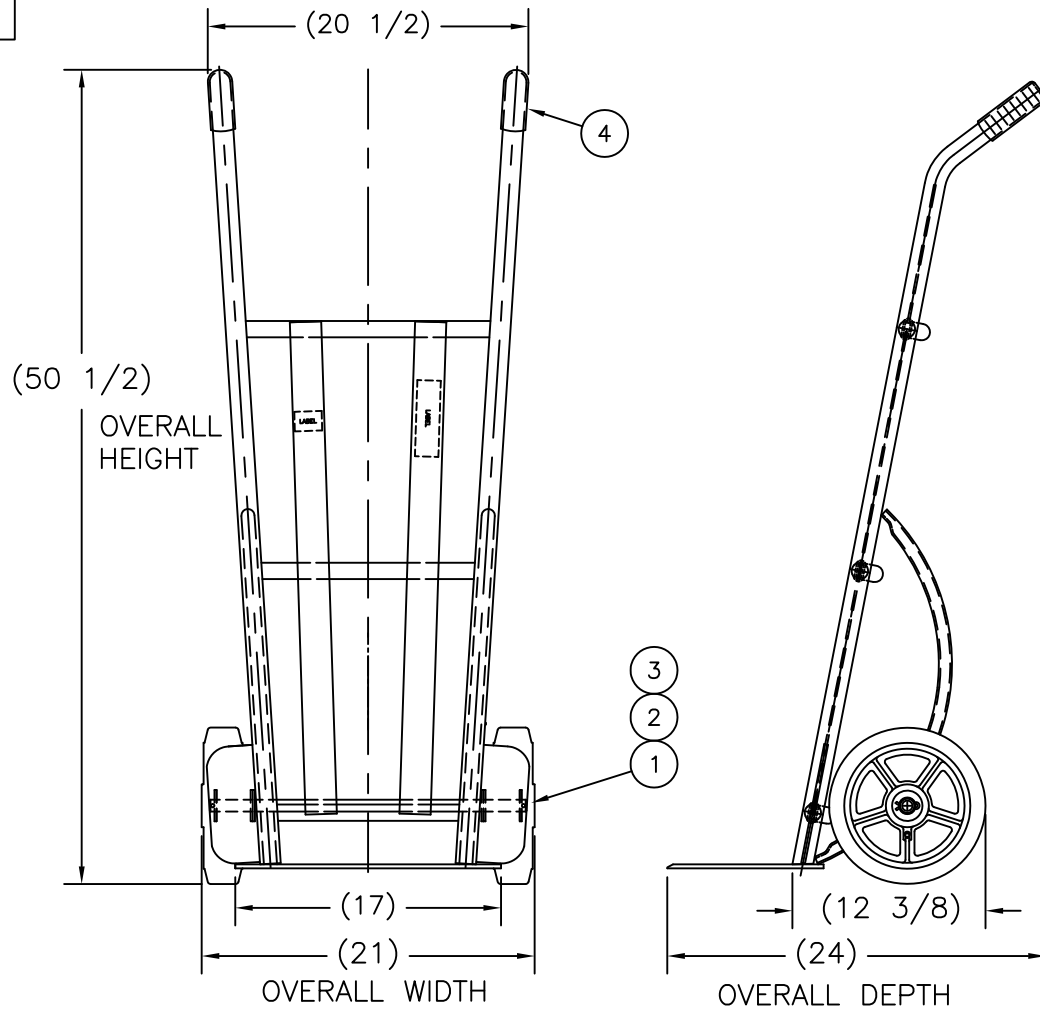

REPLACEMENT PARTS LIST

ITEM	PART NO.	DESCRIPTION	QTY.
1	150596	WHEEL: "BT" 10 x 2.5	2
2	108204	WASHER: FLAT, 3/4 SAE	2
3	108218	PIN: COTTER 3/16 X 1-1/2"	2
4	108433	HANDGRIP: YELLOW	2
* 5	108304	BAG: POLY 28 X 52	1

P/N 210239

\* NOT SHOWN

Model: TM-BT  
 Capacity: 1000  
 Weight: 67 lbs  
 Wheel: BT-1, 10" x 2.5"  
 Hub: Cast Iron  
 Type: Moldon Rubber  
 Box: No

HEAVY DUTY WAREHOUSE TRUCKS

- 5 year weld guarantee.
- Large 10" deep x 16.5" wide x .25" thick tapered nose plate.
- 1" heavy duty sch-40 pipe frame.
- Wheels guards standard.
- Dual handle design.
- Kick out four wheel model -TM4W or standard two wheel model.
- 3.5" moldon rubber swivel casters on four wheel kick out trucks.

PRINT ISSUED

JUL 10 2007

WESCO MANUFACTURING  
 ENGINEERING DEPARTMENT

REV. ECN & DATE REVISIONS APP	WESCO INDUSTRIAL PRODUCTS INC.		NORTH WALES PENNA. 19454	
	PART NAME		DRAWN: DAS 9-19-95	
	TM-BT		CHECKED: EGK 9-20-95	
	TOLERANCE UNLESS OTHERWISE SPECIFIED		APP. ENGR.	
FRACTION		3 PLACE DECIMAL	2 PLACE DECIMAL	SCALE: 10" = 1"
± 1/64		± .005	± .01	
ANGULAR ± 1-1/2"		SHEET 1 OF 1		B- 210239
BREAK ALL SHARP EDGES AND REMOVE ALL BURRS				REV

