

VERTICAL/HORIZONTAL STRAPPING CART - STRAP-VH

APPROX WEIGHT: 143.19 lbs.
 DOES NOT INCLUDE WEIGHT OF POWER OR PACKAGING!!!

*** ANY ADDITIONS, DELETIONS, OR OMISSIONS MUST BE CORRECTED ON THIS DRAWING AS THIS DRAWING WILL BE CONSIDERED ALL INCLUSIVE ***

ALL GRAPHICS PROVIDED ARE FOR REFERENCE ONLY. IF CERTAIN DIMENSIONS ARE CRITICAL PLEASE VERIFY THOSE DIMENSIONS WITH YOUR SALESPERSON

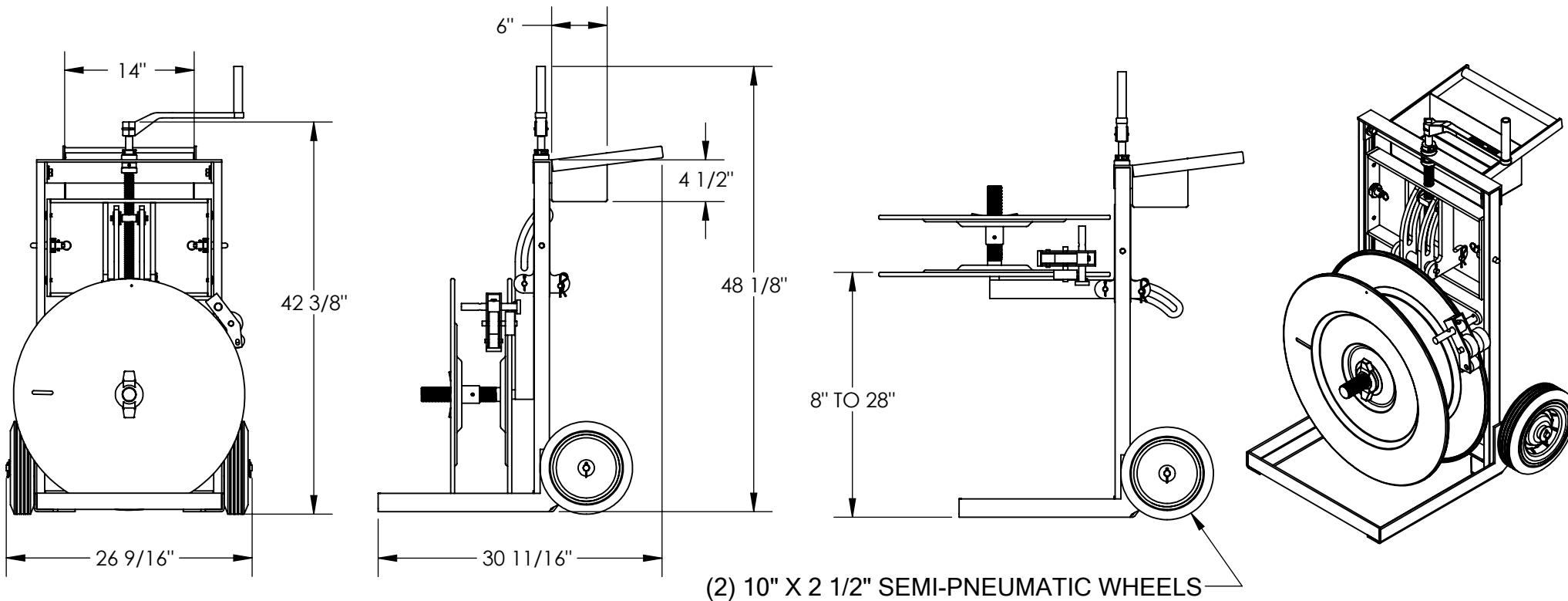

STANDARD FEATURES

- MODEL NUMBER IS STRAP-VH
- OVERALL WIDTH IS 26 9/16"
- OVERALL LENGTH IS 30 11/16"
- OVERALL HEIGHT IS 48 1/8"
- STRAP MAX. RAISED HEIGHT IS 28"
- STRAP MAX. LOWERD HEIGHT IS 8"
- EQUIPMENT TRAY MEASURES 14" X 6" X 4 1/2"
- EQUIPPED WITH (2) 10" X 2 1/2" SEMI-PNEUMATIC WHEELS

DIMENSION TOLERANCE ± 1/2"

A P P R O V A L

I, THE UNDERSIGNED, AGREE THAT THE PRODUCT AS REPRESENTED SATISFIES DESIGN AND DIMENSION REQUIREMENTS. I ALSO ACKNOWLEDGE MY DUTY TO CONFIRM PRODUCT AND INSTALLATION COMPLIANCE WITH ALL APPLICABLE FEDERAL, STATE AND LOCAL REGULATIONS AND STANDARDS.

ANY MODIFIED UNITS ARE NON-RETURNABLE

As drawn As marked

Signed: _____ Date: _____

Printed Name: _____

LEAD TIME WILL START UPON RECEIPT OF SIGNED APPROVAL DRAWING

SPECIAL FEATURES

NONE

FOR INTERNAL USE ONLY PROJECT SIGN OFF	
SALES	
ENG.	
FAB.	
POWER	

DISTRIBUTOR'S NAME:		P.O.#
VESTIL MANUFACTURING		X
DRAWN BY: DY	DATE: 10/25/10	W.O.#
REFERENCE: X	SCALE: 1:16	X
QUOTED LEAD TIME: X	QUOTE #	FILE NAME:
	X	45-007-001