

MANUAL PALLET PROBE STRAPPING CART - STRAP-P2

APPROX WEIGHT: 79 lbs.
 DOES NOT INCLUDE WEIGHT OF POWER OR PACKAGING!!!

*** ANY ADDITIONS, DELETIONS, OR OMISSIONS MUST BE CORRECTED ON THIS DRAWING AS THIS DRAWING WILL BE CONSIDERED ALL INCLUSIVE ***

ALL GRAPHICS PROVIDED ARE FOR REFERENCE ONLY. IF CERTAIN DIMENSIONS ARE CRITICAL PLEASE VERIFY THOSE DIMENSIONS WITH YOUR SALESPERSON

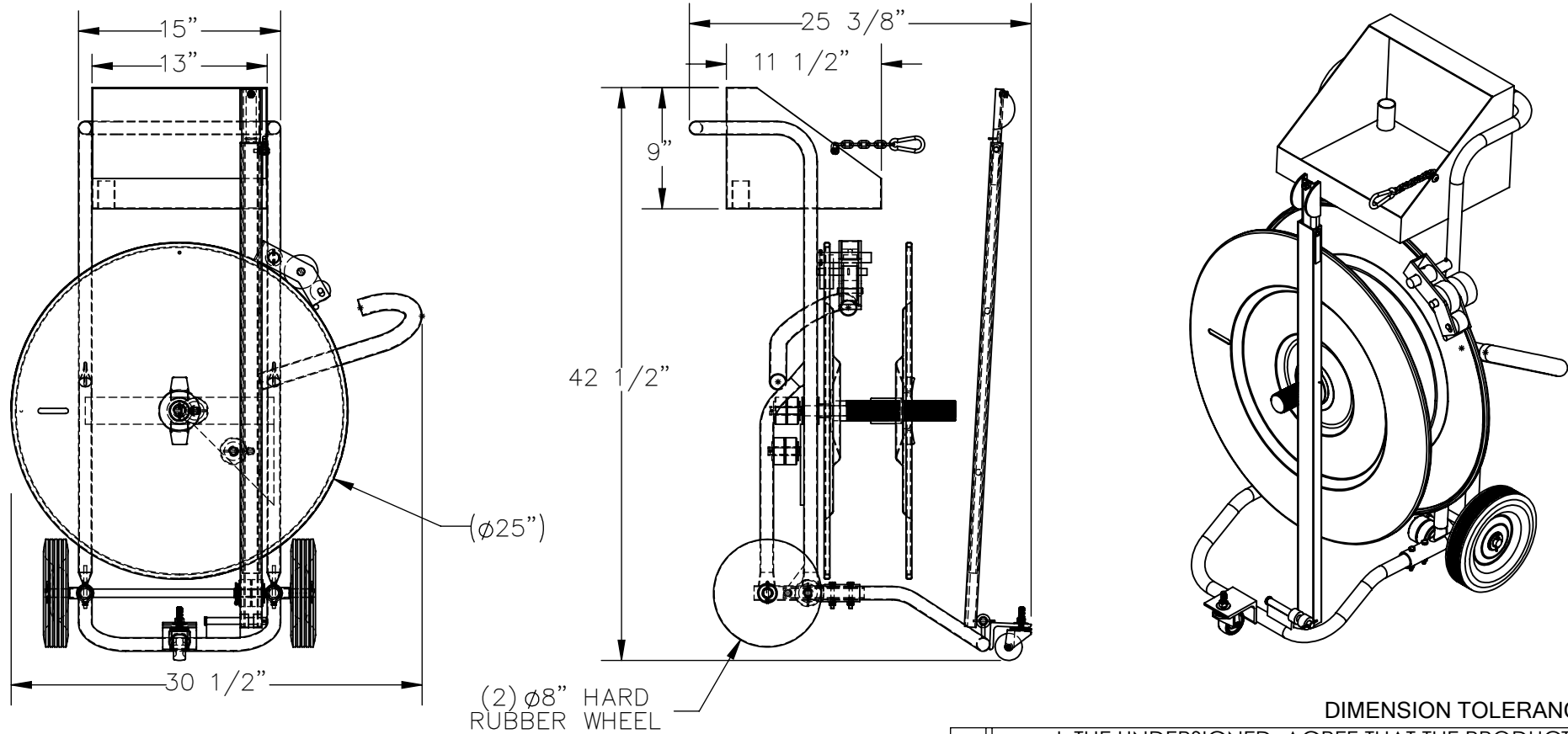

DIMENSION TOLERANCE $\pm 1/4''$

STANDARD FEATURES

- MODEL NUMBER IS STRAP-P2
- OVERALL WIDTH IS $30 \frac{1}{2}''$
- USABLE WIDTH IS $25''$
- OVERALL LENGTH IS $25 \frac{3}{8}''$
- OVERALL HEIGHT IS $42 \frac{1}{2}''$
- EQUIPMENT TRAY MEASURES $13'' \times 11 \frac{1}{2}'' \times 9''$
- TOUGH BAKED IN POWDER COATED BLUE AND YELLOW FINISH
- 8" HARD RUBBER WHEEL

SPECIAL FEATURES

NONE

APPROVAL

I, THE UNDERSIGNED, AGREE THAT THE PRODUCT AS REPRESENTED SATISFIES DESIGN AND DIMENSION REQUIREMENTS. I ALSO ACKNOWLEDGE MY DUTY TO CONFIRM PRODUCT AND INSTALLATION COMPLIANCE WITH ALL APPLICABLE FEDERAL, STATE AND LOCAL REGULATIONS AND STANDARDS.

ANY MODIFIED UNITS ARE NON-RETURNABLE

[] As drawn [] As marked

Signed: _____ Date: _____

Printed Name: _____

LEAD TIME WILL START UPON RECEIPT OF SIGNED APPROVAL DRAWING

FOR INTERNAL USE ONLY PROJECT SIGN OFF	
SALES	
ENG.	
FAB.	
POWER	

DISTRIBUTOR'S NAME:		P.O.#
VESTIL MANUFACTURING		X
DRAWN BY: CRH		W.O.#
DATE: 11/1/2018		X
REFERENCE: X	SCALE: 1:12	SALES: X
QUOTED LEAD TIME: X	QUOTE # X	FILE NAME:
		45-007-023