

# PORTABLE STEEL HOPPER - P-HOP-1

APPROX WEIGHT: 431.88 lbs.  
DOES NOT INCLUDE WEIGHT OF POWER OR PACKAGING!!!

\*\*\* ANY ADDITIONS, DELETIONS, OR OMISSIONS MUST BE CORRECTED ON THIS DRAWING AS THIS DRAWING WILL BE CONSIDERED ALL INCLUSIVE \*\*\*

ALL GRAPHICS PROVIDED ARE FOR REFERENCE ONLY. IF CERTAIN DIMENSIONS ARE CRITICAL PLEASE VERIFY THOSE DIMENSIONS WITH YOUR SALESPERSON

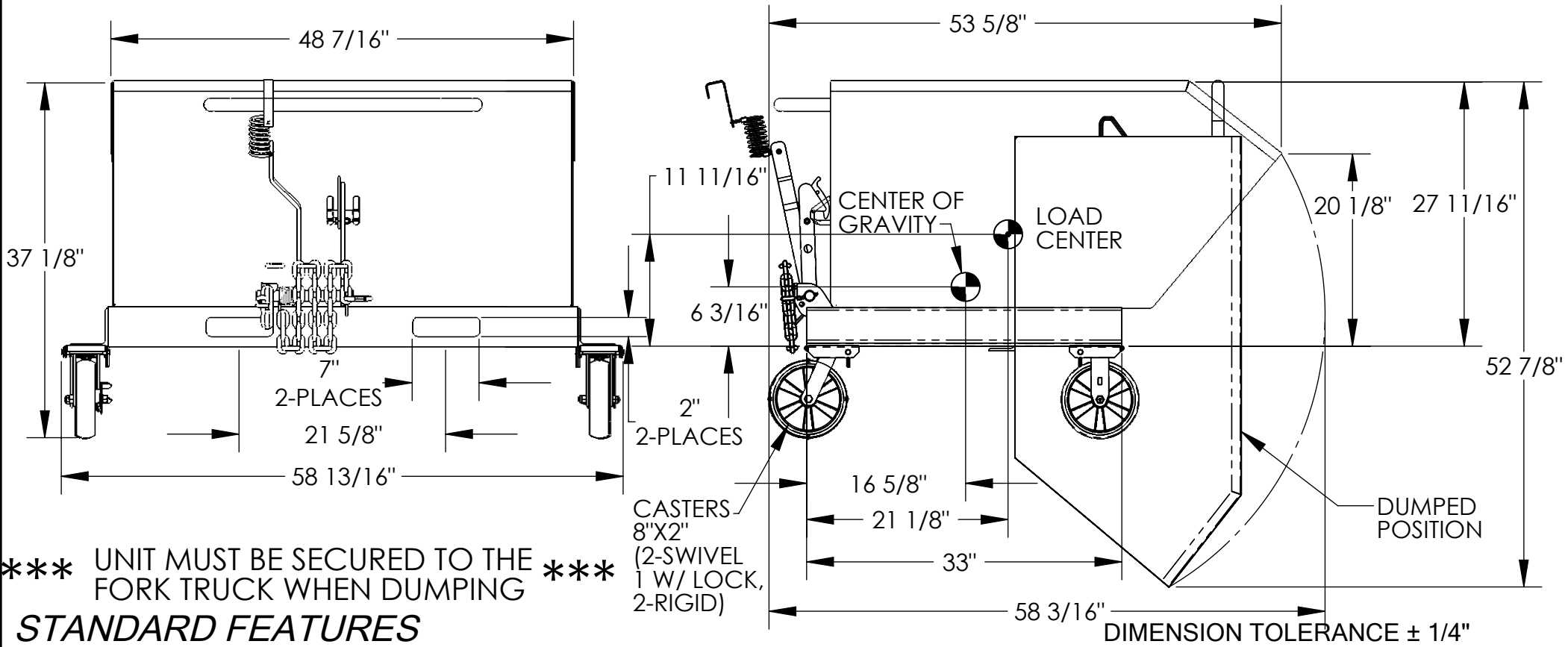

\*\*\* UNIT MUST BE SECURED TO THE FORK TRUCK WHEN DUMPING \*\*\*

## STANDARD FEATURES

- MODEL NUMBER: P-HOP-1
- CAPACITY: 2,000 LBS.
- VOLUME: 1 CU. YD.
- USABLE WORK ENVELOPE: 58 13/16" X 58 3/16" X 52 7/8"
- DUMP ANGLE: 90°
- OVERALL WIDTH: 58 13/16"
- OVERALL LENGTH: 53 5/8"
- OVERALL HEIGHT: 37 1/8"
- FORK POCKETS: 7" WIDE X 2" HIGH
- CASTERS: 8"X2" (2-SWIVEL 1 W/ LOCK, 2-RIGID)
- TOUGH BAKED IN POWDER COATED BLUE FINISH

## SPECIAL FEATURES

NONE

NEVER EXCEED LOAD CENTER RATING PER FORK TRUCK MANUFACTURER'S GUIDELINES. DO NOT USE THIS FORK TRUCK ATTACHMENT IF LOAD WILL EXCEED FORK TRUCK MANUFACTURER'S LOAD CENTER RATING.

I, THE UNDERSIGNED, AGREE THAT THE PRODUCT AS REPRESENTED SATISFIES DESIGN AND DIMENSION REQUIREMENTS. I ALSO ACKNOWLEDGE MY DUTY TO CONFIRM PRODUCT AND INSTALLATION COMPLIANCE WITH ALL APPLICABLE FEDERAL, STATE AND LOCAL REGULATIONS AND STANDARDS.

**ANY MODIFIED UNITS ARE NON-RETURNABLE**

[ ] As drawn [ ] As marked

Signed: \_\_\_\_\_ Date: \_\_\_\_\_

Printed Name: \_\_\_\_\_

LEAD TIME WILL START UPON RECEIPT OF SIGNED APPROVAL DRAWING

DISTRIBUTOR'S NAME: VESTIL MANUFACTURING

P.O.# X

W.O.# X

SALES: X

FILE NAME: 37-007-001

DRAWN BY: W. STALEY DATE: 9/18/08

REFERENCE: X SCALE: 1:15

QUOTED LEAD TIME: X QUOTE # X

FOR INTERNAL USE ONLY PROJECT SIGN OFF	
SALES	
ENG.	
FAB.	
POWER	

DIMENSION TOLERANCE ± 1/4"