

BULK BAG LIFTER - BBL-4

APPROX WEIGHT: 91.00 lbs.
DOES NOT INCLUDE WEIGHT OF POWER OR PACKAGING!!!

ANY ADDITIONS, DELETIONS, OR OMISSIONS MUST BE CORRECTED ON THIS DRAWING AS THIS DRAWING WILL BE CONSIDERED ALL INCLUSIVE

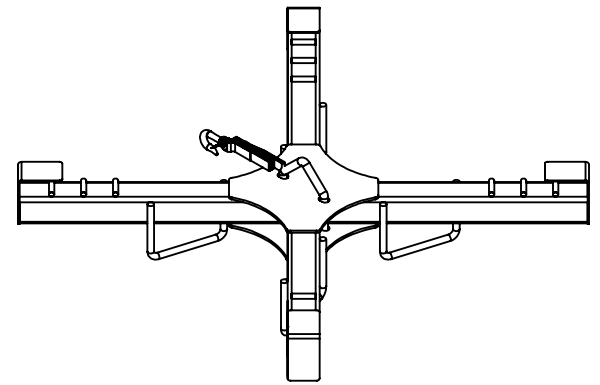
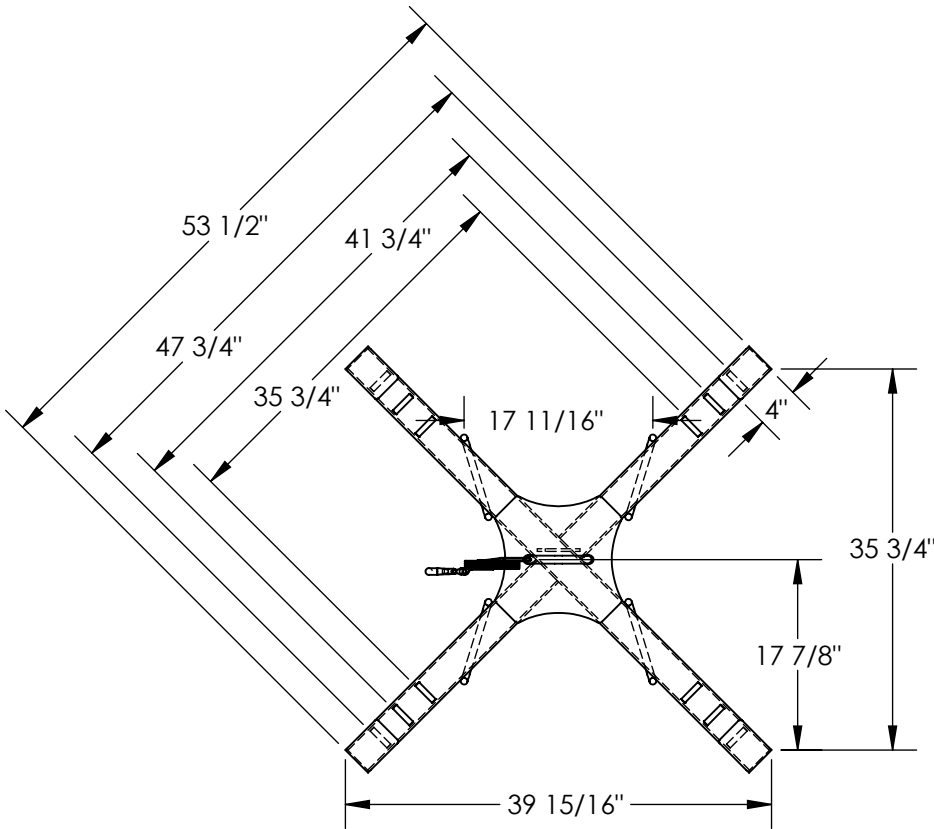

APPROX. WEIGHT / LOST LOAD = 91 LBS.
CAPACITY = 4,000 # EVENLY DISTRIBUTED
NEVER EXCEED LOAD CENTER RATING PER
FORK TRUCK MANUFACTURER'S GUIDELINES.
EFFECTIVE THICKNESS WILL VARY DEPENDING
ON APPLICATION & TYPE OF FORK TRUCK

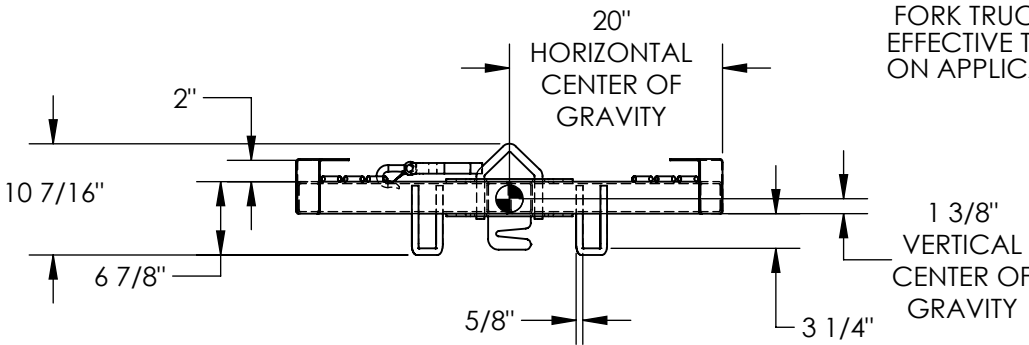

ALL GRAPHICS PROVIDED ARE FOR REFERENCE ONLY. IF CERTAIN DIMENSIONS ARE CRITICAL PLEASE VERIFY THOSE DIMENSIONS WITH YOUR SALESPERSON

FOR INTERNAL USE ONLY PROJECT SIGN OFF	
SALES	
ENG.	
FAB.	
POWER	

STANDARD FEATURES

- MODEL NUMBER IS BBL-4
- CAPACITY IS 4,000 LBS
- OVERALL WIDTH IS 53 1/2"
- USABLE WIDTH IS UP TO 47 3/4"
DEPENDING ON BAG STRAPS
- OVERALL LENGTH IS 39 15/16"
- USABLE LENGTH IS 35 3/4"
- OVERALL HEIGHT IS 10 7/16"
- BAG LINER HOOK
- INCLUDES 48 1/2"L FORK TRUCK
RESTRAINT STRAP
- TOUGH BAKED IN POWDERCOATED
BLUE FINISH

SPECIAL FEATURES

NONE

DIMENSION TOLERANCE ± 1/4"

A P P R O V A L	I, THE UNDERSIGNED, AGREE THAT THE PRODUCT AS REPRESENTED SATISFIES DESIGN AND DIMENSION REQUIREMENTS. I ALSO ACKNOWLEDGE MY DUTY TO CONFIRM PRODUCT AND INSTALLATION COMPLIANCE WITH ALL APPLICABLE FEDERAL, STATE AND LOCAL REGULATIONS AND STANDARDS.	
	ANY MODIFIED UNITS ARE NON-RETURNABLE	
	[] As drawn [] As marked	
	Signed: _____ Date: _____	
Printed Name: _____		
<i>LEAD TIME WILL START UPON RECEIPT OF SIGNED APPROVAL DRAWING</i>		

DISTRIBUTOR'S NAME:		P.O.#
VESTIL MANUFACTURING		X
		W.O.#
DRAWN BY: RAL		X
DATE: 06/17/2014		SALES: X
REFERENCE: X	SCALE: 1:18	FILE NAME:
QUOTED LEAD TIME: X	QUOTE # X	47-007-011