

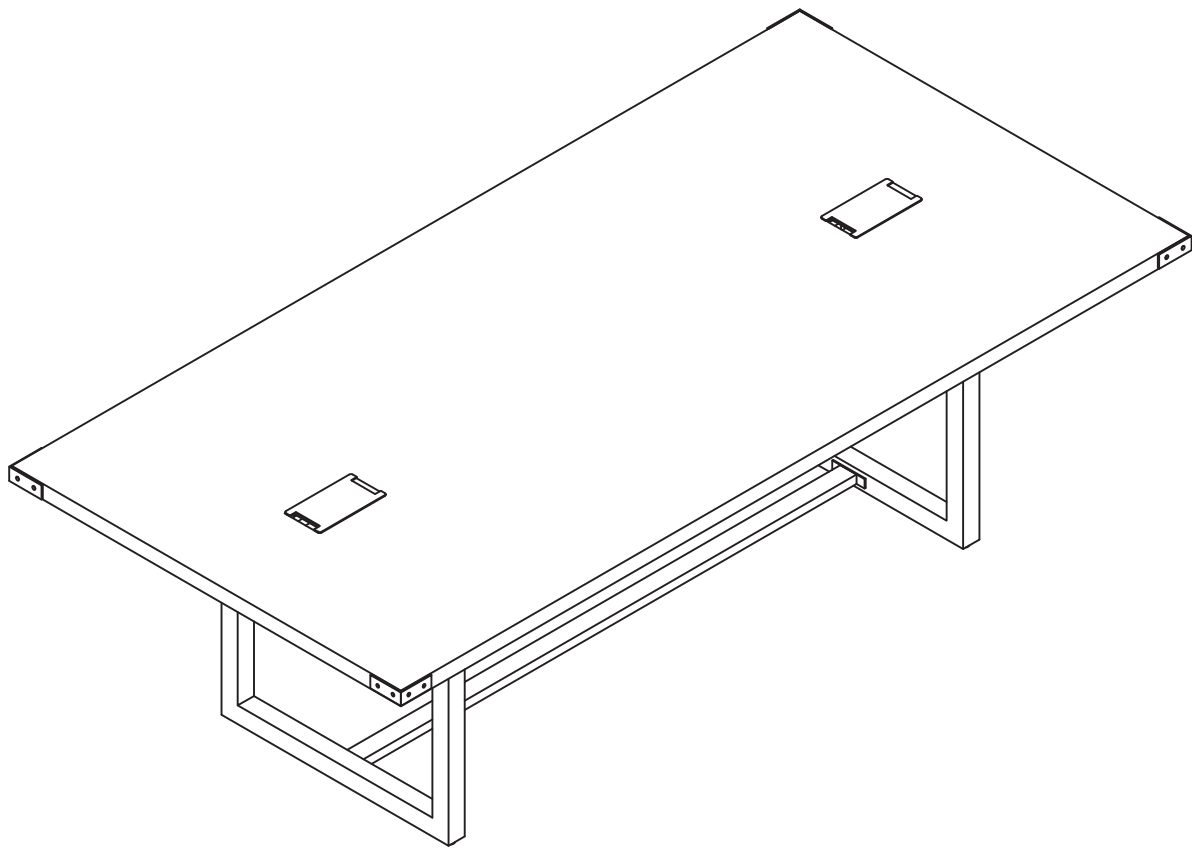













Mirella Series
96" Sitting Conference Table
Model No. MRCS8

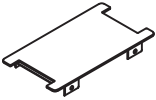

For questions or concerns, please call 1-888-971-6225 available
Monday-Friday 7:30 AM to 5:00 PM (Central Time)
(English-speaking operators)

PARTS LIST

| Name | Part | Qty. | Spare Qty |
|------|---|------|-----------|
| A |  Leg | 2 | |
| B |  Frame | 4 | |
| C |  Foot Rest | 1 | |
| D |  100*100*38*4mm | 4 | |
| E |  Stand-off Ø20*76 | 2 | |
| F |  Leveler | 2 | |
| G |  870mm | 1 | |

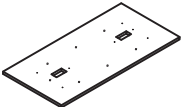
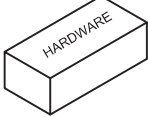
| Name | Part | Qty. | Spare Qty |
|------|--|------|-----------|
| H |  Grommet | 2 | |
| I |  M6*35mm | 12 | 1 |
| J |  M6*15mm | 12 | 1 |
| K |  M4*14mm | 16 | 1 |
| L |  M4.2*16mm | 8 | 1 |
| M |  Top Panel | 1 | |
| |  MRCS8HB | | |

Items with HB are in hardware box.

IMPORTANT!

Review ALL instructions before beginning assembly. These instructions are provided to avoid problems that may occur from improper assembly or installation. SAFCO and/or its distributor are not responsible for failure resulting from improper assembly or installation of this product. Moreover, all warranties are void for failure to follow these assembly instructions.

- 1 Use Screw (J) to connect Leg (A), Frame (B) and Foot Rest (C) together;

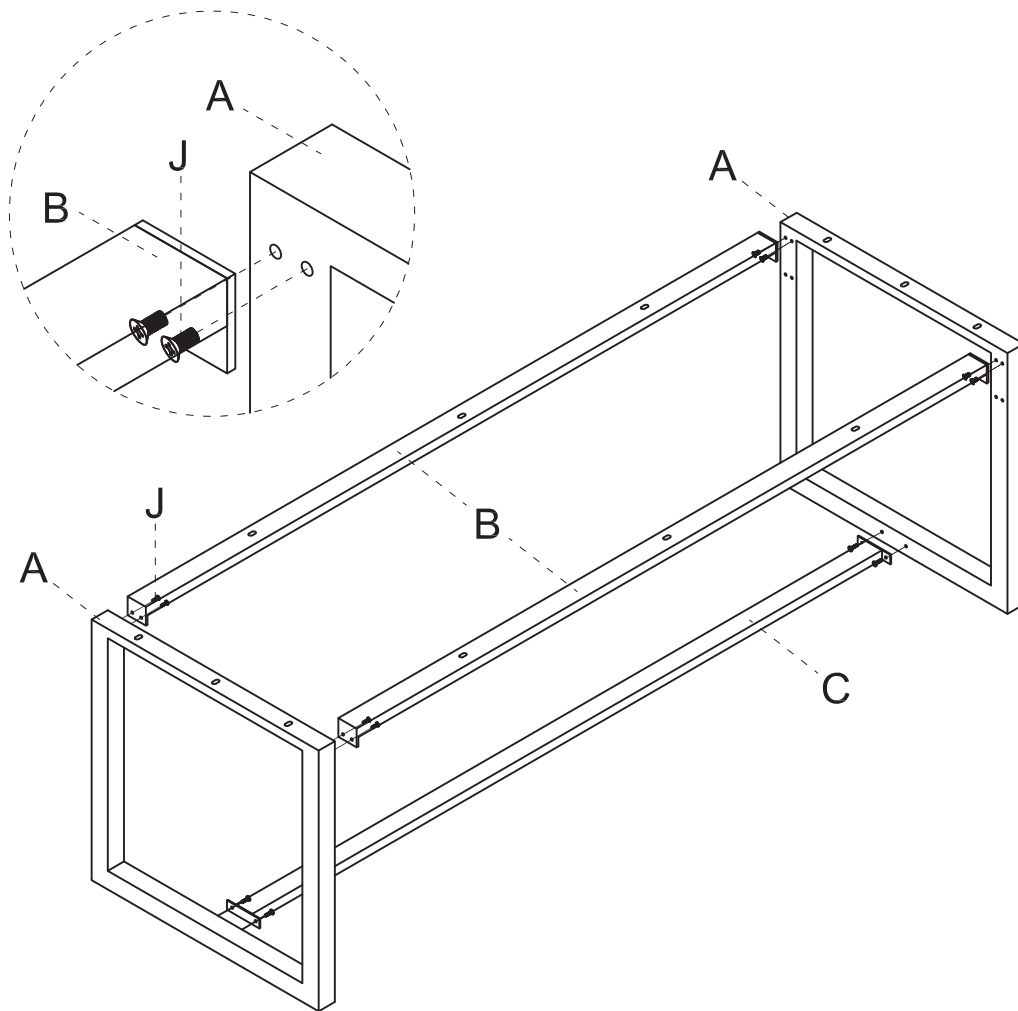

- ② Install Stand-off (E) on Top Panel (M), Use the Leveler (F) to connect the Wire Management Tray (G) with the Stand-off (E);

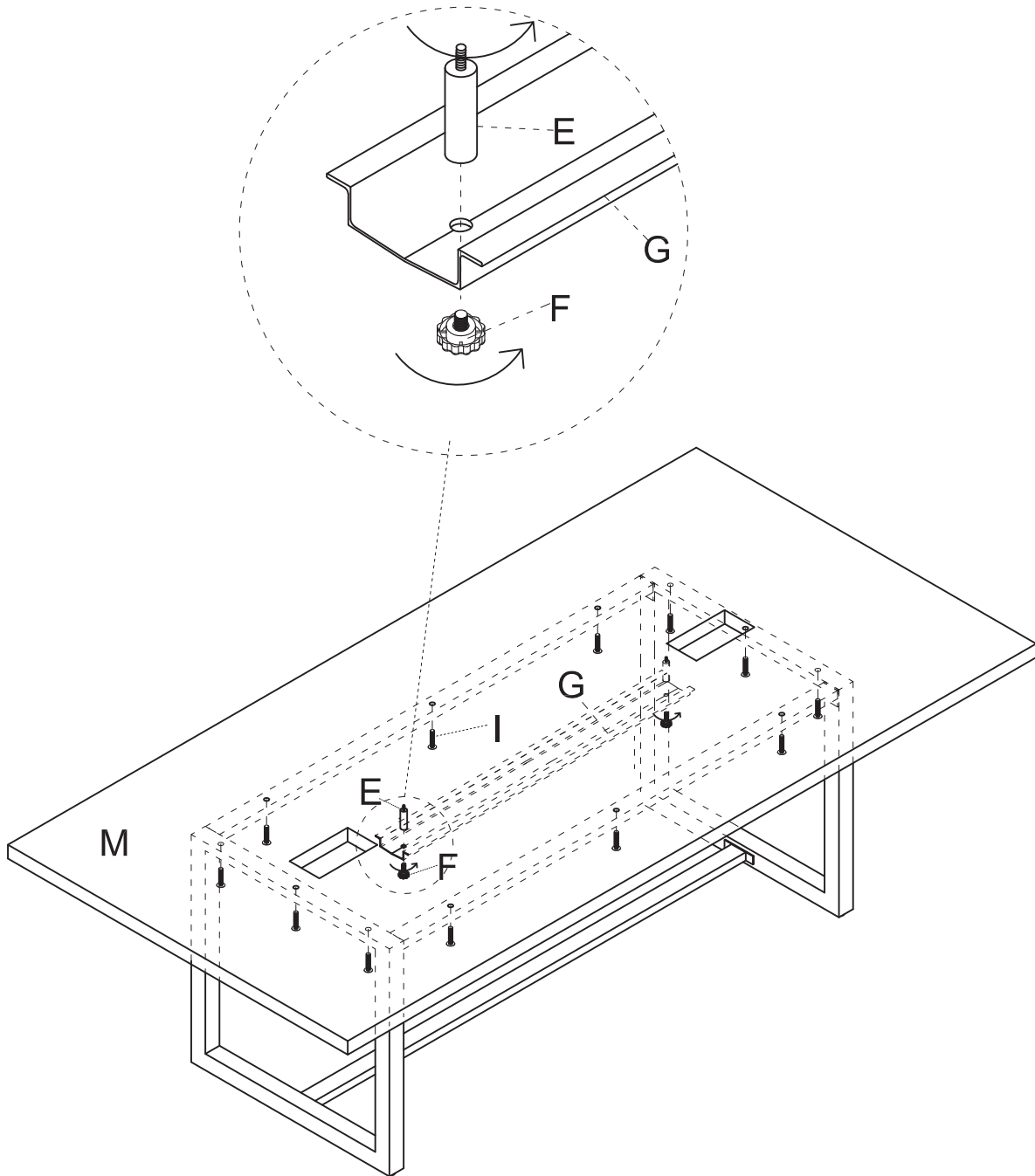

3 Use Screw (L) to connect Leg (A) and Frame (B);

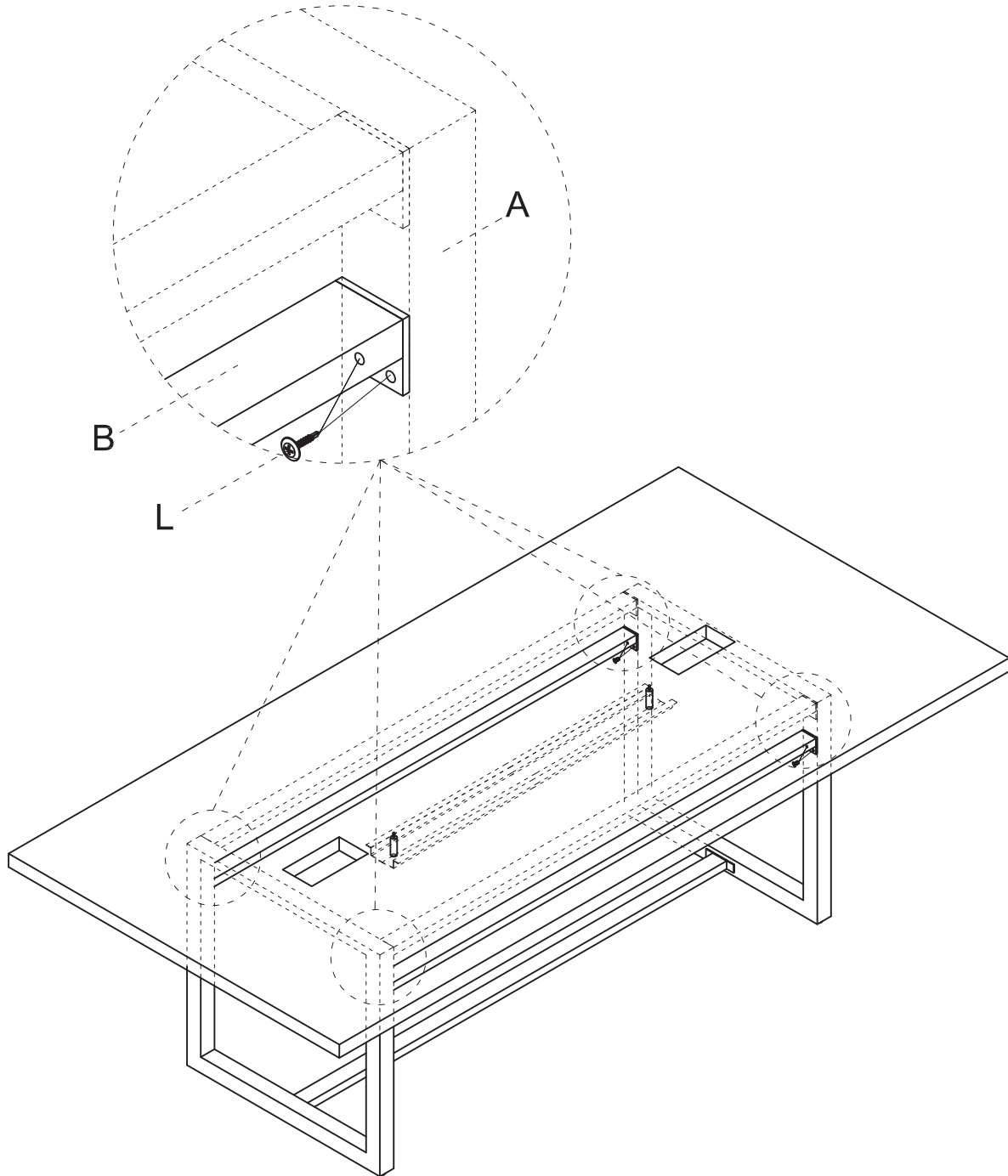

- ④ Use Screw (K) to connect L Bracket (D) to the Top Conner; then put the Grommet (H) to the Top (M).

