

NB Series

SETUP AND OPERATION MANUAL

FOR NB430, NB440, NB470 & NB480



NB Series

Setup and Operation Manual

For NB430, NB440, NB470 & NB480

Document Number: NB430_440_470_480_00_D
Revision Date: March, 2018

Release Date: September, 2016

COPYRIGHT

All copyrights to this document are owned by Newcastle Systems, Inc. No part of the contents of this document may be reproduced or transmitted in any form or by any means without the prior written consent of Newcastle Systems, Inc.

NOTICE

Newcastle Systems, Inc. shall not be liable for errors contained herein. Newcastle Systems, Inc. shall not be liable for any damages whatsoever, including, without limitation, damages for loss of business profits, business interruption, loss of business information, or other pecuniary loss arising out of the use of this documentation even if Newcastle Systems, Inc. has been made aware of the possibility of such damages.

Information contained in this document is subject to change without notice. While every effort is made to ensure that the information is accurate as of the publication date, users are reminded to update their use of this document with documents published by Newcastle Systems, Inc. subsequent to this date. Updates may be available at www.newcastlesys.com or by contacting Newcastle Systems, Inc.

Copyright © 2018 by Newcastle Systems, Inc.
ALL RIGHTS RESERVED
Printed in U.S.A.

Newcastle Systems, Inc.
73 Ward Hill Avenue
Haverhill, MA 01835

(781) 935-3450
www.newcastlesys.com

Table of Contents

About This Manual

Symbols and Conventions	v
Newcastle Systems Technical Support	v

The NB Series

Standard Contents	1
Optional Accessories	1
Tools Required	1
Setting up the NB Series	2
One Battery Setup for NB430	3
Two Battery Setup for NB440, NB470 & NB480	5
Testing the Battery Function	7
Tips for Proper Cart Operation	8
Troubleshooting Tips	8
Frequently Asked Questions	9

Index

About This Manual

Symbols and Conventions

Symbols are used in this manual and on the product itself to ensure correct usage, to prevent danger to the user and others and to prevent property damage. The symbols are defined below. It is important that you read these descriptions and fully understand them.



Caution

This symbol indicates information that, if ignored, could result in personal injury or harm to the equipment due to incorrect handling.



Warning

This symbol indicates information that, if ignored, could result in death, serious physical injury or destruction of property due to incorrect handling.



Indicates important procedures

Note: Indicates important related information, reminders and recommendations

Italics Used for emphasis, for indicating the first occurrence of a new term and for book titles

1. Numbered list - Used when the order of the items is important

- Bulleted list - Used when items are of equal importance, but the order is unimportant

Newcastle Systems Technical Support

You can reach Technical Support by telephone. Dial (781) 935-3450, then select 3 for technical support.

When requesting assistance, please be ready to provide the following information:

- Your name and telephone number
- Product model and serial number
- Brief description of the problem and list of symptoms
- Steps you have already taken to try to resolve the problem

If the Product is Damaged

If any portion of the unit is damaged, forward an immediate request to the delivering carrier to perform an inspection of the product and to prepare a damage report. Save the container and all packing materials until the contents are verified.

Also report the damage, along with the model and serial numbers, to Newcastle Systems Customer Service at (781) 935-3450 so that action can be initiated to either repair or replace the damaged items. Do not return any items to Newcastle Systems until you obtain instructions from Customer Service.

Upon receipt of this information, Newcastle Systems will provide service instructions, or a return authorization number and shipping information.

The NB Series

Standard Contents

Each cart will come with the following standard contents:

- Cart (assembled)
- Battery and hardware
- Trash can holder and green can

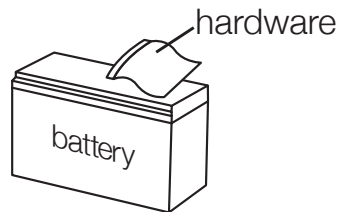
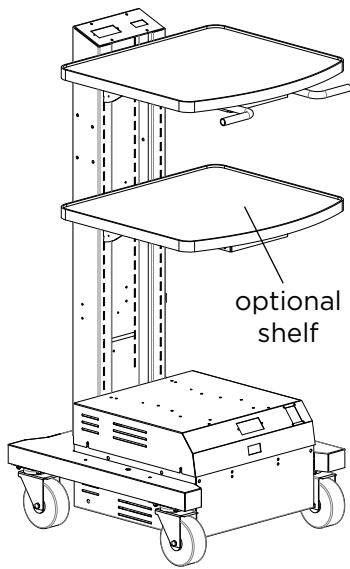

One or two batteries,
depending on model
purchased.

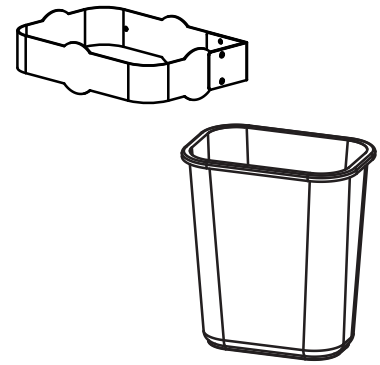

Optional Accessories

Any optional accessories that were ordered with the cart will either be installed on the cart or shipped separately in a box with the cart.

Note: Some accessories may be placed in the power cabinet for shipping purposes.

Tools Required

One 10 mm open end or socket wrench

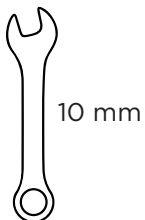

Setting up the NB Series

1. Open the power box by loosening the (4) thumbscrews.

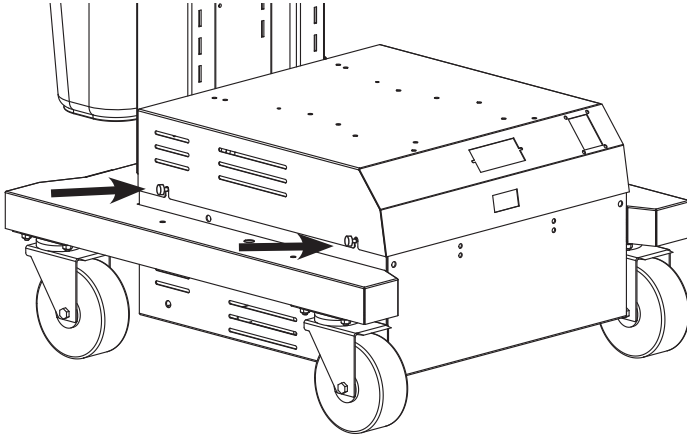

2. Next, remove the power box cover.

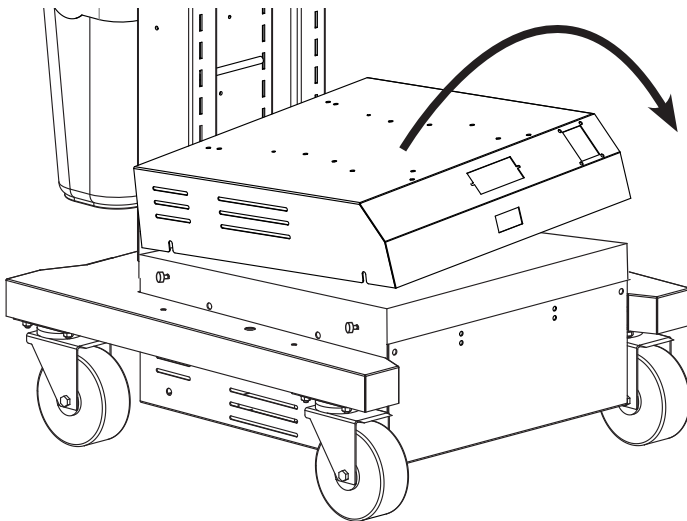

Once the cover has been removed from the power box, proceed to the appropriate section on battery installation according to the number of batteries your cart has.

- For one battery installation, see [“One Battery Setup for NB430”](#) on page 3.
- For two battery installation, see [“Two Battery Setup for NB440, NB470 & NB480”](#) on page 5.

One Battery Setup for NB430

Battery Wire Connections Overview

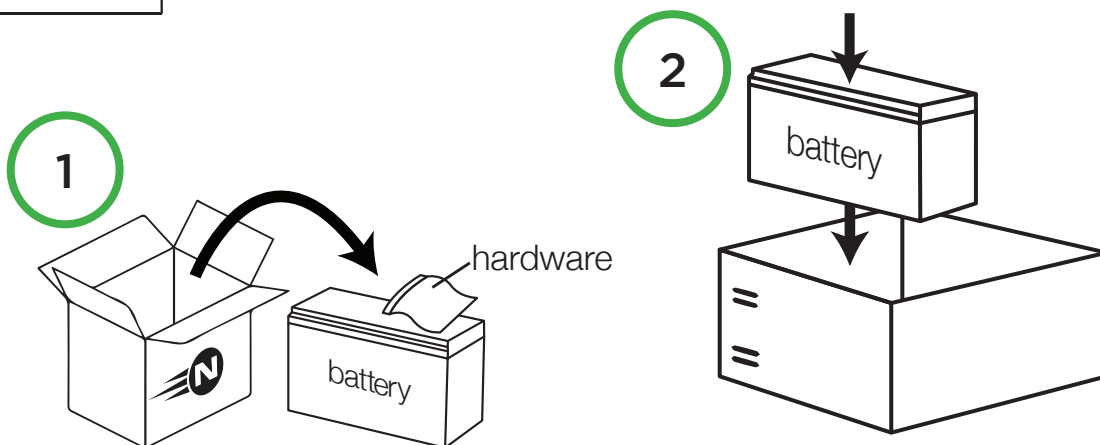
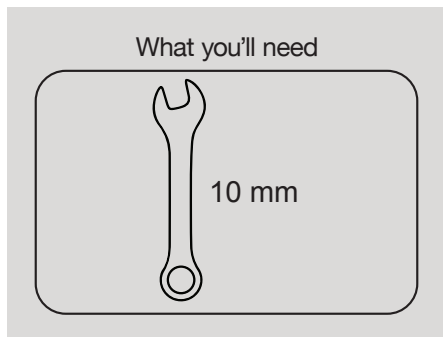
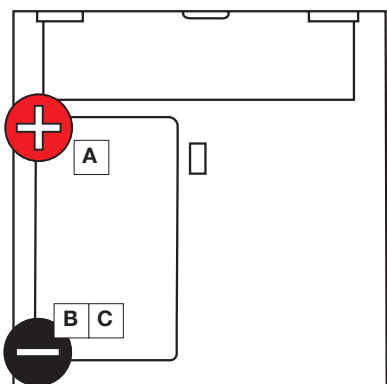

Hardware

bolts

lock washers

flat washers

Wire Connections

A B C

red black black

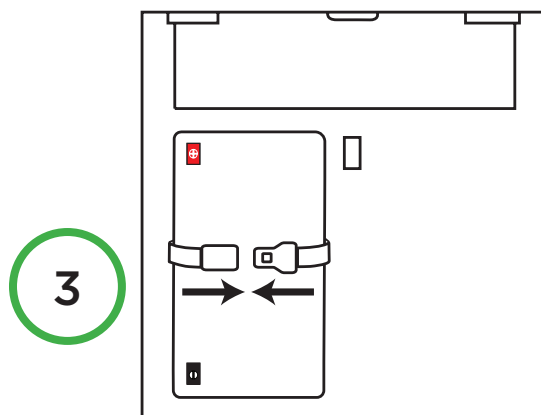

*** Tighten bolts with 10 mm wrench**
Sparkling is normal during initial connection.

**** Pull rubber boot over tightened terminal**

After performing step 5, proceed to "Testing the Battery Function" on page 7.

4

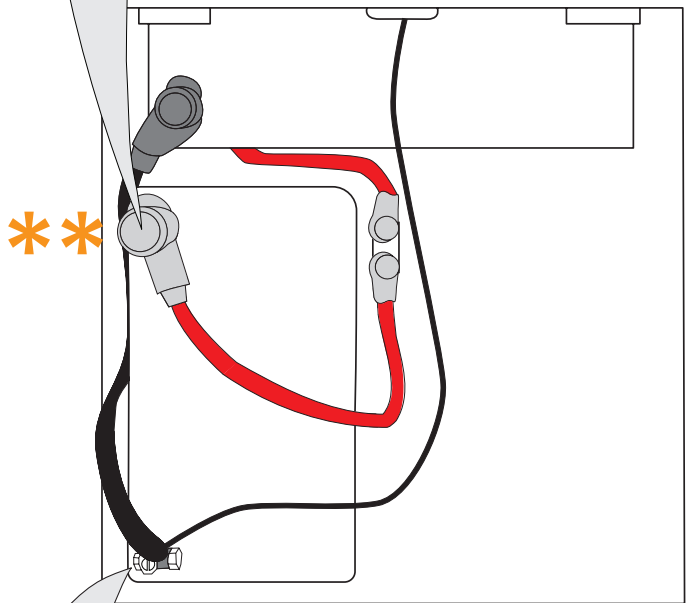
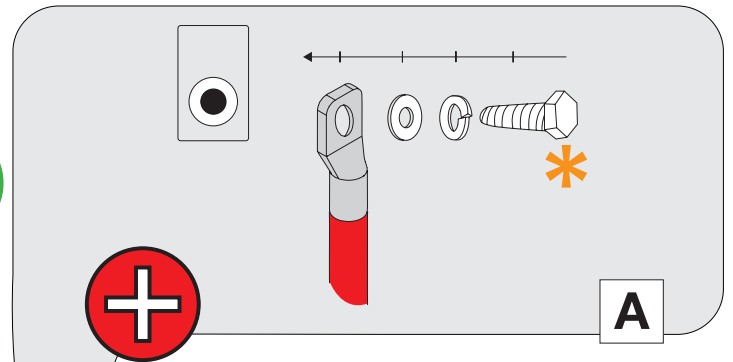

5

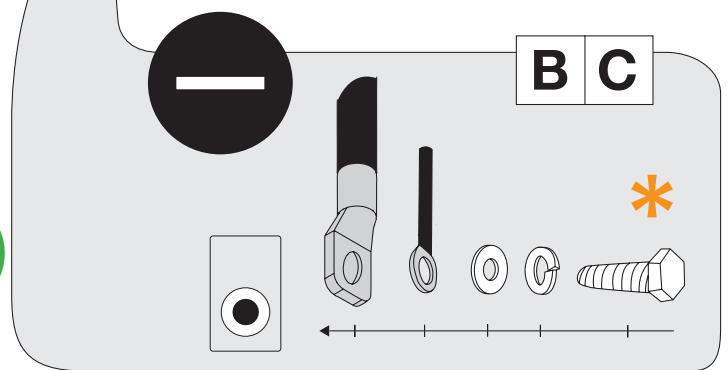

Hardware

bolts
lock washers
flat washers

Wire Connections

A **B** **C**

red **black** **black**

Two Battery Setup for NB440, NB470 & NB480

Battery Wire Connections Overview

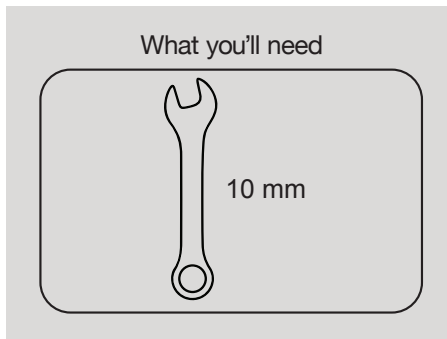
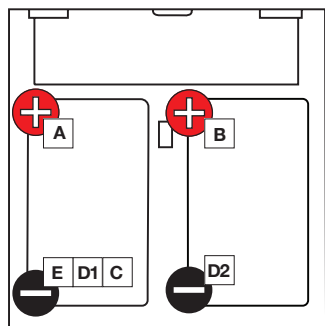

Hardware

Wire Connections

A B C

red red black

D1 D2

black

E

black

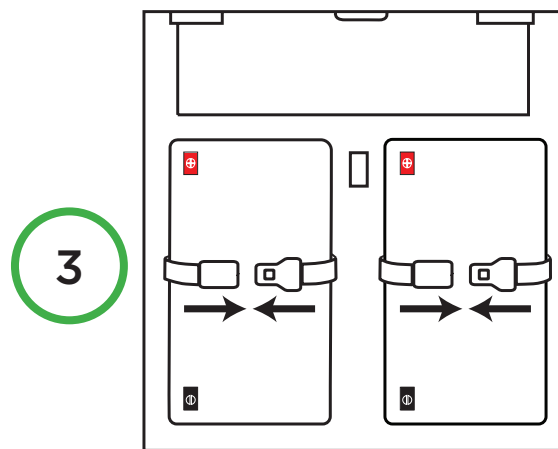
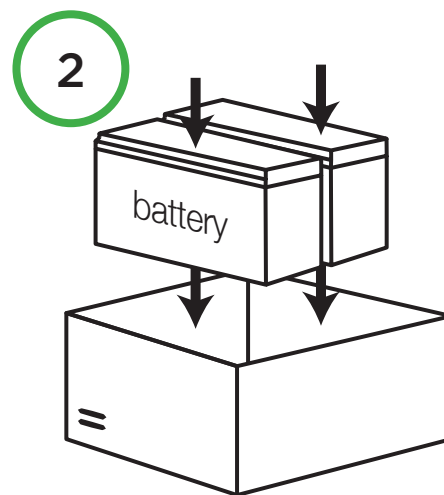
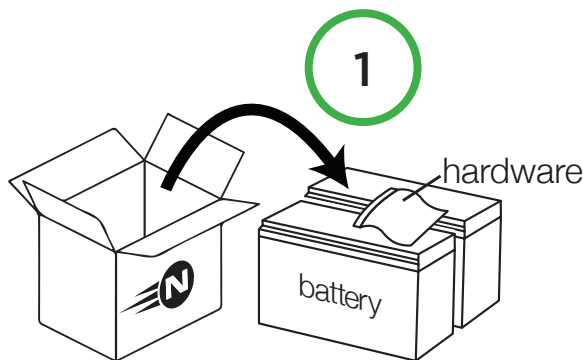

*** Tighten bolts with 10 mm wrench**
Sparkling is normal during initial connection.

**** Pull rubber boot over tightened terminal**

Hardware

bolts
lock washers
flat washers

Wire Connections

A B C
red red black

D1 D2
black black

E
black

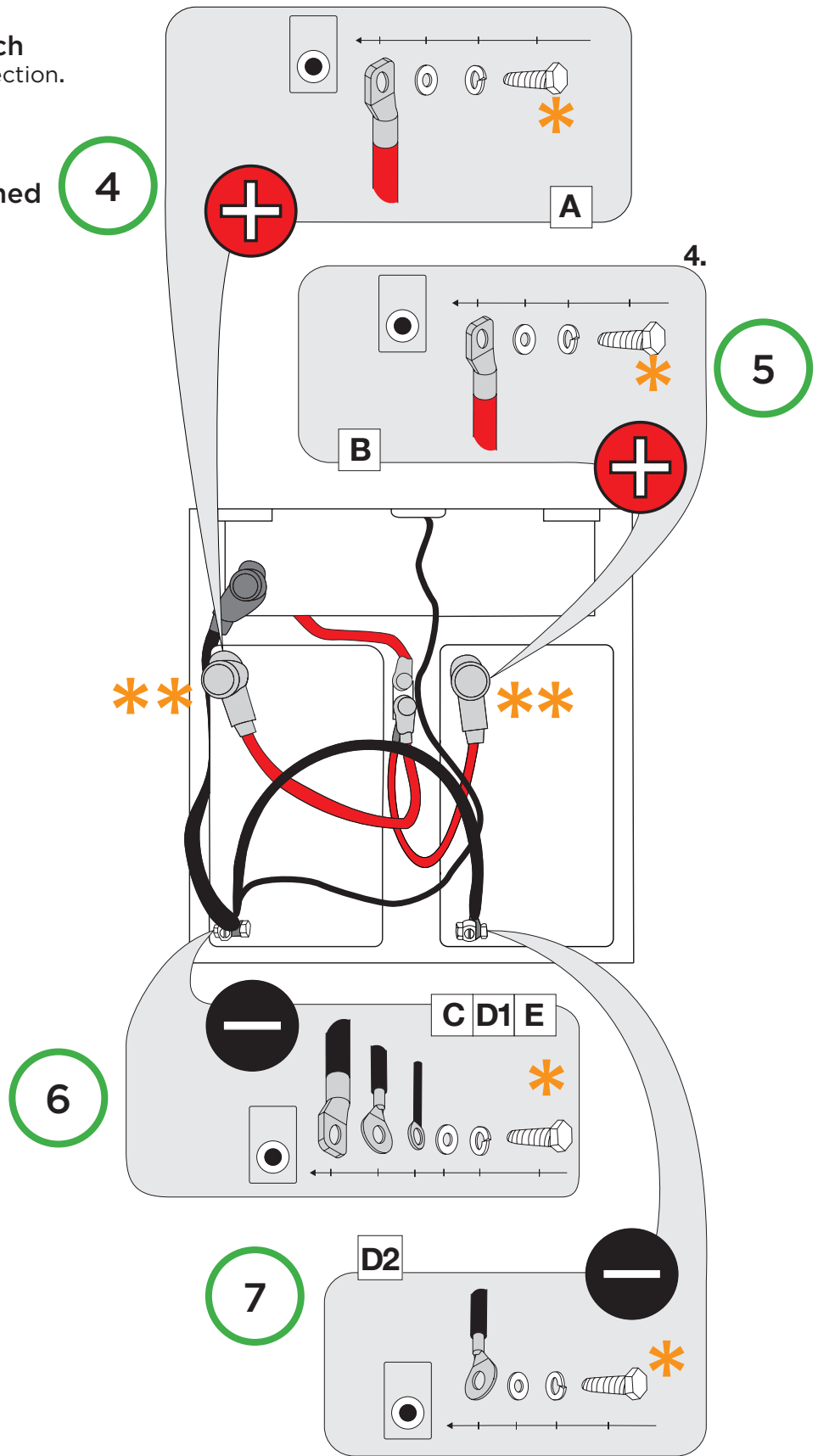

Testing the Battery Function

Make sure all fittings are tight and that the battery is strapped down in the cabinet. Test the unit before replacing the power box cover.

1. Turn the unit on by pressing the green power button.

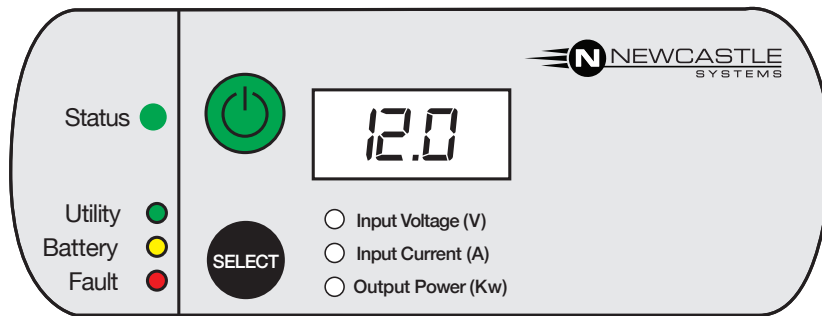

2. Turn the power strip on. The light should turn red.

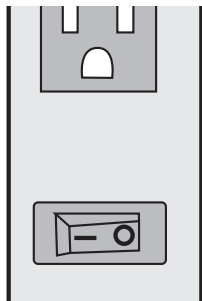

3. Place the power box cover on and tighten the thumb screws..

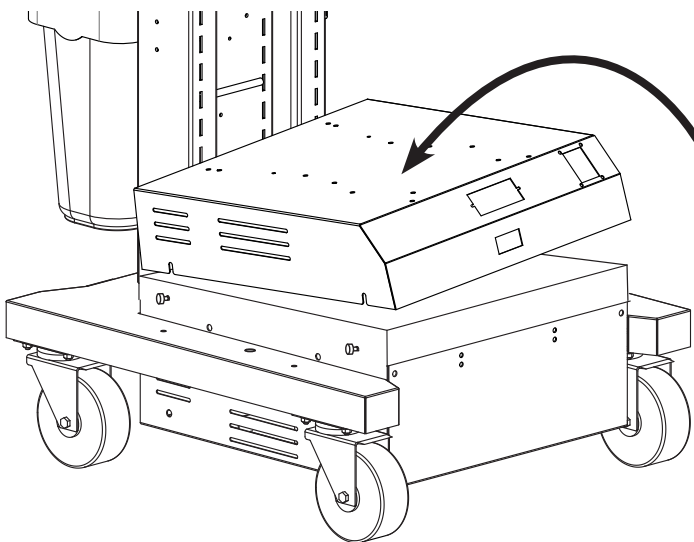

Tips for Proper Cart Operation

- Charge your battery before using it to ensure it is fully charged. Simply plug the charger cord (located on the side of the unit) into a standard wall outlet.
- Monitor the battery status meter on the cart.

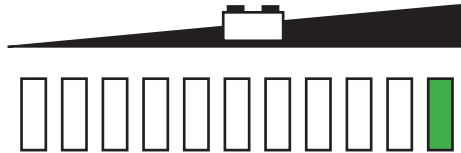

Battery Light Meter Indicators

Voltage	11.2	11.4	11.5	11.7	11.8	12.0	12.1	12.3	12.4	12.6
Light #	1	2	3	4	5	6	7	8	9	10
Color	Red Blinks	Red Blinks	Yellow	Yellow	Yellow	Green	Green	Green	Green	Green

- Batteries should not be discharged below 11.5 volts because this will shorten the life of the battery.
- Batteries *should not* be stored in a discharged state. They should be charged as soon as possible after each use (otherwise it can void the warranty). If a battery is left in a discharged state for a period of time, it may no longer take a charge.
- Avoid exposing battery to heat, service life is shortened at ambient temperatures above 85F.
- When powering equipment on the cart, it's okay to have the charger plugged in if necessary. In this case, the AC power will pass through the charger and power your equipment directly.
- When the cart is not in use, the system charger can be plugged into a wall outlet to ensure the battery remains in its optimal state. Turn the unit to the OFF position.

Troubleshooting Tips

Is your cart displaying an error code? Here's what those mean:

ERROR	CONDITION	MODE	SUGGESTED ACTION
E01	Low battery voltage shutdown, depends on settings	Inverting	<ul style="list-style-type: none"> • Check battery status meter and recharge if necessary • Check that cables are connected properly • Make sure that cables are secured tightly
E02	High battery voltage shutdown, greater than 15.5v	Inverting	<ul style="list-style-type: none"> • Check for external charging sources, such as an over voltage alternator - disconnect if necessary
E03	AC output overload shutdown	Inverting	<ul style="list-style-type: none"> • Reduce the amount of loads connected • Check the appliances for high-surge ratings and disconnect if necessary
E04	Over temperature shutdown	Inverting	<ul style="list-style-type: none"> • Reduce the amount of loads connected • Check for proper ventilation • Check for ambient temperature and move to a cooler location when possible

Frequently Asked Questions

QUESTION	ANSWER
<p>What does ABS/BUL or FUL mean?</p>	<ul style="list-style-type: none"> • These are normal codes you should see every charging cycle BUL = Bulk mode ABS = Absorption mode FUL = Full
<p>What are my inverter/charger settings?</p>	<ul style="list-style-type: none"> • While plugged in and charging, press the “select” button to view your current settings • Recommended settings: NB430/440: IN1, 20A, AL1, SDL NB470: IN1, 40A, AL1, SDL NB480: IN1, 35A, AL1, Ag
<p>Why is my unit not charging?</p>	<ul style="list-style-type: none"> • Loose connections. Ensure that all wiring is correct and tight • Check that charger is not set to a low setting • Batteries may be old and depleted
<p>Where do the LED battery meters plug in?</p>	<p>Red #1 - fuse to slot 1 (top right) Black - battery to slot 2 (top left) Red #2 - slot 1 to slot 4 (bottom right)</p>
<p>How old are my batteries?</p>	<ul style="list-style-type: none"> • Located on the top center of your battery there is a date code • It is a five digit code followed by one or two letters • The first two digits are the month and the last digit is the year (ex: 11243 would indicate the batteries are from November 2013)

Index

A

Accessories 1

B

Battery 8

Age 9

Light Meter 8

C

Caution v

Contents, Standard 1

Conventions v

Customer Service v

D

Damaged Unit v

E

Error Codes 8

I

Inverter/Charger Settings 9

L

Light Meter 8

O

One Battery Setup 3

S

Settings, Inverter/Charger 9

Setup

One Battery 3

Two Battery 5

Symbols v

T

Technical Support v

Testing the Battery 7

Tips for Proper Operation 8

Tools Required 1

Troubleshooting Tips 8

Two Battery Setup 5

W

Warning v

