

PALLET DOLLY FLOOR BRAKE INSTRUCTIONS

Item	Description	Qty.	Part Number
Pallet Dolly Floor Brake Kit <i>(includes all items below)</i>			33491
A	Floor lock bracket weldment	1	33490
B	Hex head cap screw - 5/16"-18 x 2" long	2	80015
C	Hex lock nut - 5/16"-18	6	80676
D	Backing plate for floor lock mount	1	33485
E	Pan head recess screw - 5/16"-18 x 1" long	4	80313
F	Flat washer for 5/16" bolt	4	80701
G	Floor lock	1	33051

TOOLS REQUIRED

- (1) 1/2" SOCKET WRENCH
- (1) 1/2" OPEN END WRENCH
- (1) #3 PHILLIPS SCREWDRIVER
- Ø 5/16" (.312) DRILL BIT
- (1) DRILL MOTOR
- (1) PAINT PEN OR PUNCH

Step 1

[Paint pen or punch; Ø 5/16" (.312) drill bit and drill motor]

Use the bracket weldment (A) as a template; place against the frame end of the pallet dolly against either side of the frame weld plate, as shown. Mark holes in the weldment on the frame. Drill holes where marked.

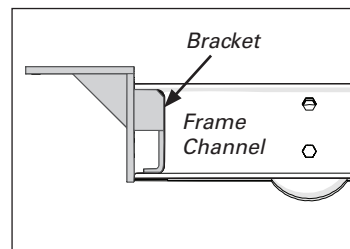
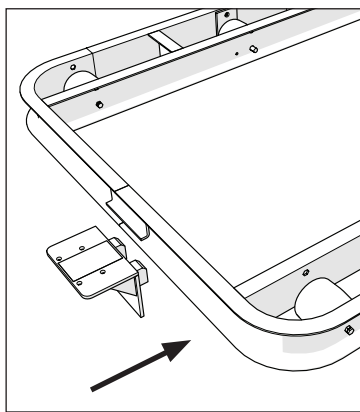

Make sure that the bracket is snug inside the frame channel before marking holes.

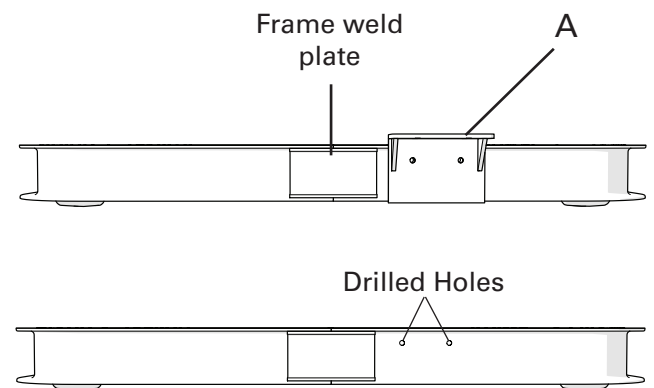

Front View

Step 2

(1/2" wrenches)

Attach the bracket weldment to the pallet dolly frame using the hex head screws (B), backing plate (D) and lock nuts (C).

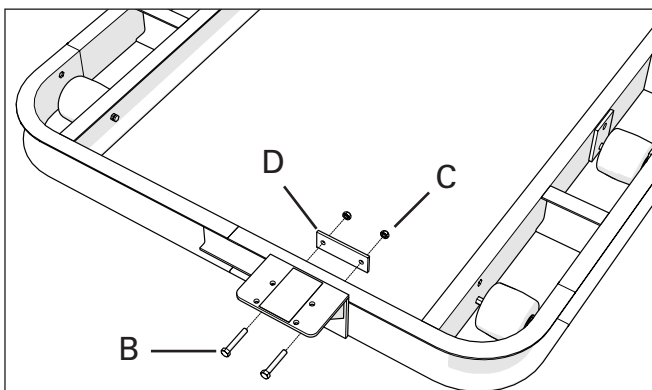

Step 3

(1/2" wrench, #3 screwdriver)

Attach the floor brake (G) to the bracket weldment using the pan head screws (E), washers (F) and lock nuts (C).

