

TILT MASTER STRADDLE - TMS-40-AC

APPROX WEIGHT: 953 lbs.
DOES NOT INCLUDE WEIGHT OF POWER OR PACKAGING!!!

*** ANY ADDITIONS, DELETIONS, OR OMISSIONS MUST BE CORRECTED ON THIS DRAWING AS THIS DRAWING WILL BE CONSIDERED ALL INCLUSIVE ***

ALL GRAPHICS PROVIDED ARE FOR REFERENCE ONLY. IF CERTAIN DIMENSIONS ARE CRITICAL PLEASE VERIFY THOSE DIMENSIONS WITH YOUR SALESPERSON

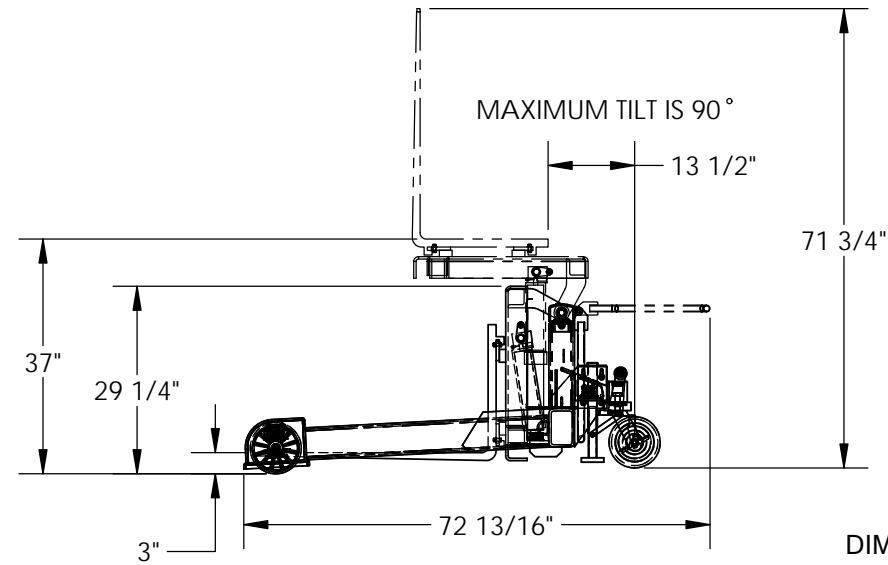
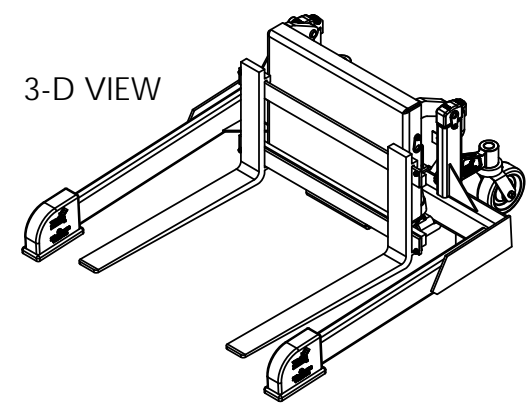
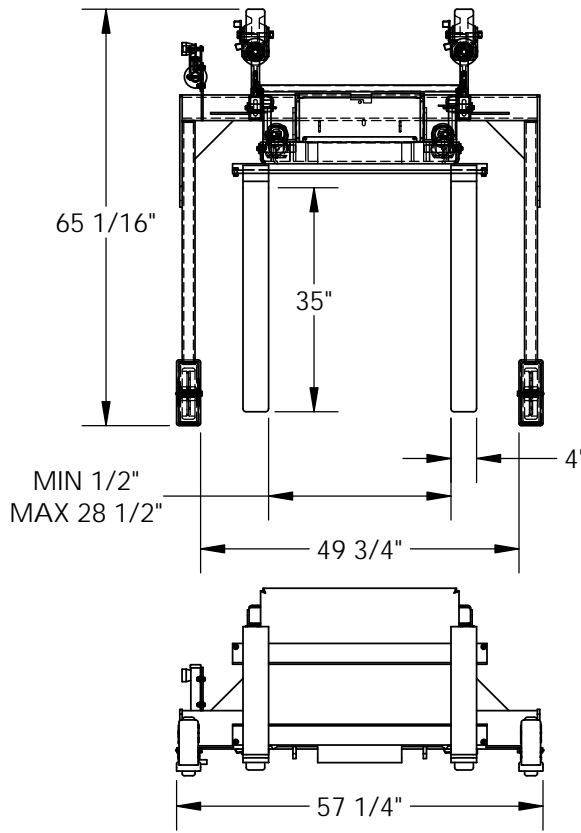

FOR INTERNAL USE ONLY PROJECT SIGN OFF	
SALES	
ENG.	
FAB.	
POWER	

DIMENSION TOLERANCE ± 1/4"

STANDARD FEATURES

- MODEL NUMBER IS TMS-40-AC
- CAPACITY IS 4,000 lbs
- FORK ADJUSTMENT IS 1/2" TO 28 1/2" I.D.
- OPERATOR REACH IS 13 1/2"
- STRADDLE I.D. IS 49 3/4"
- FORK WIDTH IS 4"
- USABLE FORK LENGTH IS 35"
- OVERALL WIDTH IS 57 1/4"
- OVERALL LENGTH IS 72 13/16"
- OVERALL HEIGHT IS 29 1/4"
- LOWERED FORK HEIGHT IS 3"
- ROTATED HEIGHT IS 37"
- INCLUDES FLOOR LOCK
- 115 VOLT AC POWERED

SPECIAL FEATURES

NONE

PLEASE CIRCLE SPECIFICATIONS:

POWER	<input checked="" type="checkbox"/> AC	* <input type="checkbox"/> DC	* <input type="checkbox"/> AIR/OIL	
MOTOR VOLTAGE	<input checked="" type="checkbox"/> 115	<input type="checkbox"/> 208	<input type="checkbox"/> 230	<input type="checkbox"/> 460
DEDICATED CIRCUIT REQUIRED				
MOTOR PHASE	<input checked="" type="checkbox"/> SINGLE	<input type="checkbox"/> THREE		
CONTROL	<input checked="" type="checkbox"/> HAND	* <input type="checkbox"/> FOOT		
~ ALL BATTERY CHARGERS ARE 115V AC ~				
* BATTERY CHRG.	<input type="checkbox"/> REMOTE	<input type="checkbox"/> ON-BOARD		
* CHRG. INDICATOR	<input type="checkbox"/> YES	<input type="checkbox"/> NO		

* AVAILABLE AT ADDITIONAL COST

APPROVAL

I, THE UNDERSIGNED, AGREE THAT THE PRODUCT AS REPRESENTED SATISFIES DESIGN AND DIMENSION REQUIREMENTS. I ALSO ACKNOWLEDGE MY DUTY TO CONFIRM PRODUCT AND INSTALLATION COMPLIANCE WITH ALL APPLICABLE FEDERAL, STATE AND LOCAL REGULATIONS AND STANDARDS.

ANY MODIFIED UNITS ARE NON-RETURNABLE

[] As drawn [] As marked

Signed: _____ Date: _____

Printed Name: _____

LEAD TIME WILL START UPON RECEIPT OF SIGNED APPROVAL DRAWING

DISTRIBUTOR'S NAME:		P.O.#
VESTIL MANUFACTURING		X
DRAWN BY: M. WILSON		W.O.#
DATE: 1/29/2013		X
REFERENCE: X	SCALE: 1:30	SALES: X
QUOTED LEAD TIME: X	QUOTE #	FILE NAME:
	X	38-007-028