



Vestil Manufacturing Corp.
 2999 North Wayne Street, P.O. Box 507, Angola, IN 46703
 Telephone: (260) 665-7586 -or- Toll Free (800) 348-0868
 Fax: (260) 665-1339
 Web: www.vestilmfg.com e-mail: info@vestil.com

SLR-UM Hoist Rigging Storage Rack

Instruction Manual



Shown with caster kit.

Receiving instructions:

After delivery, remove the packaging from the product. Inspect the product closely to determine whether it sustained damage during transport. If damage is discovered, record a complete description of it on the bill of lading. If the product is undamaged, discard the packaging.

NOTE: The end-user is solely responsible for confirming that product design, use, and maintenance comply with laws, regulations, codes, and mandatory standards applied where the product is used.

Replacement Parts and Technical Assistance:

For answers to questions not addressed in these instructions and to order replacement parts, labels, and accessories, call our Technical Service and Parts Department at (260) 665-7586. The department can also be contacted online at http://www.vestilmfg.com/parts_info.htm.

Table of Contents

Signal Words.....	2
Hazards.....	2
Bills of Materials.....	3
Specifications.....	4
Assembling the Rack.....	4, 5, 6
Using the Rack.....	7
Record of Satisfactory Condition.....	7
Inspections & Maintenance.....	7, 8
Labeling Diagram.....	8
Hook Lock Option SLR-LS.....	9
Limited Warranty.....	10

Signal Words:

This manual uses SIGNAL WORDS to indicate the likelihood of personal injuries, as well as the probable seriousness of those injuries, if the product is misused in the ways described. Other signal words call attention to uses of the product likely cause property damage. The signal words used appear below along with the meaning of each word:



Identifies a hazardous situation which, if not avoided, WILL result in DEATH or SERIOUS INJURY. Use of this signal word is limited to the most extreme situations.



Identifies a hazardous situation which, if not avoided, COULD result in DEATH or SERIOUS INJURY.



Indicates a hazardous situation which, if not avoided, COULD result in MINOR or MODERATE injury.



Identifies practices likely to result in product/property damage, such as operation that might damage the crane.

Hazards:

Vestil strives to identify all foreseeable hazards associated with the use of its products. However, material handling is dangerous and no manual can address every possible risk. The most effective means for avoiding injury is for the end user to apply sound judgment whenever using this device.



Serious personal injuries could result if this product is assembled or used improperly.

- **Read and understand the entire manual before assembling, using or servicing the ladder.**
- DO NOT apply weight that exceeds the capacity of your unit. The configuration of the rack determines its capacity:
 - If caster kit is installed, overall rack capacity = 1,200 lb. (545.5kg).
 - If adjustable feet are installed, overall rack capacity = 2,000 lb. (909.1kg).
 - If the unit is anchored to a floor, overall rack capacity = 2,000 lb. (909.1kg)
 Load the lower beam first. Apply no more than *half* of the overall rack capacity to each beam.
- Uniformly distribute the total load applied to the rack.
- Regardless of rack configuration (casters; adjustable feet; or anchored to the floor), the capacity of each double hook is always 150 lb. (68.2 kg).
- Inspect the rack as instructed in the [Inspections & Maintenance](#) section on pages 7 & 8. DO NOT continue to use the rack if it is not in *original condition*. See [Record of Satisfactory Condition](#) on p. 7. If repairs are necessary, DO NOT use the product until it is fully restored to normal condition. ONLY use manufacturer-approved replacement parts.
- Evenly distribute loads on both sides of the rack. Loading only one side of the rack applies a twisting force to the beams and could cause the rack to tip.
- ONLY use this rack on even, level surfaces. If the adjustable feet are installed, make sure that the beams are level. Adjust the feet as necessary to level the rack.
- DO NOT remove or obscure a label. Every label must be in *original condition*, readable and undamaged. See [Labeling Diagram](#) on p. 8.
- DO NOT climb, or ride on, the rack.
- DO NOT modify the rack in any way. **Unapproved modifications automatically void the [Limited Warranty](#) (p. 10) and might make the rack unsafe to use.**

Bills of Materials (31-006-282 and 31-514-258)

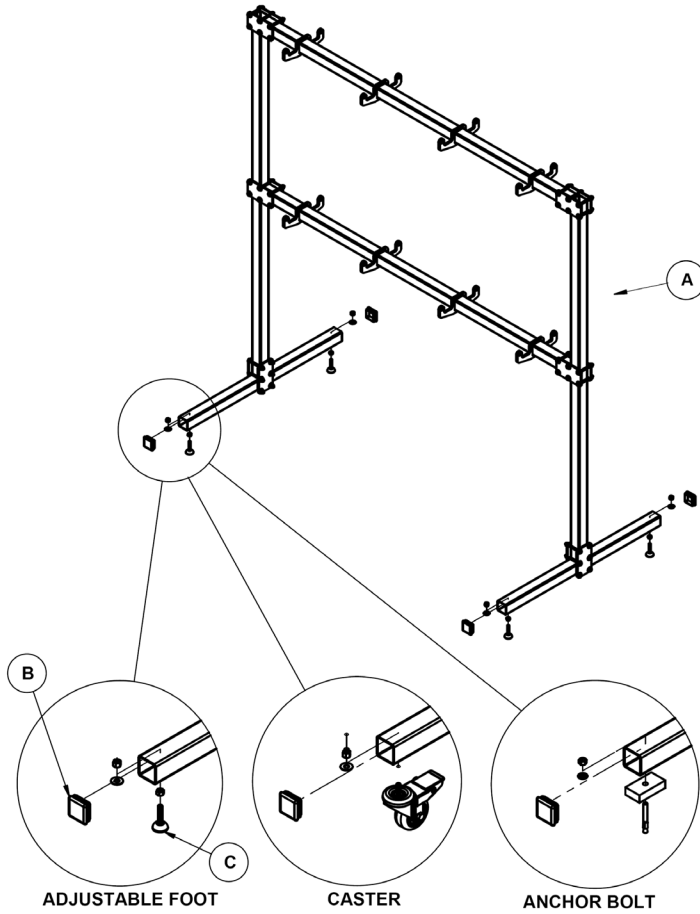

Item	Part no.	Description	Qty.
A	31-514-258	Subassembly, frame	1
B	31-024-014	Cap, square, ribbed inserts	4
C	34-154-007	Adjustable mounting feet, replacement kit	1

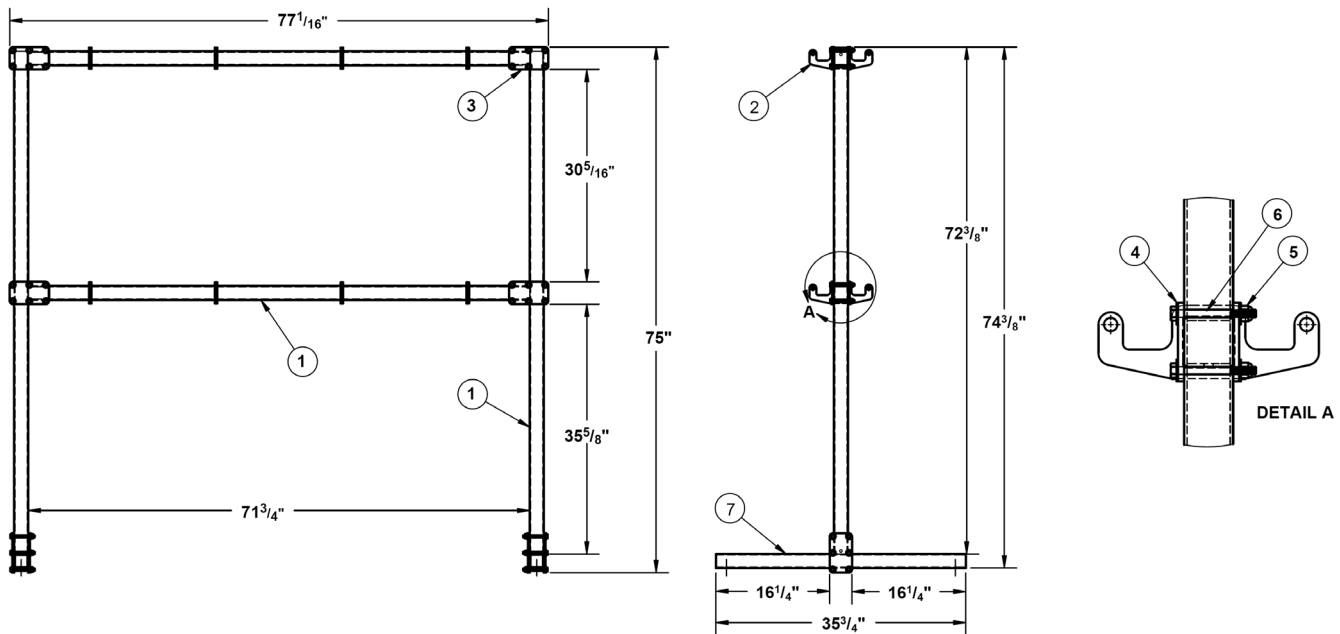

Item	Part no.	Description	Qty.	Item	Part no.	Description	Qty.
1	31-014-428	Frame, rail	4	5	37021	5/16"-18 lock nut, z-finish	36
2	31-014-430	Frame, hook, double-sided	8	6	11066	5/16"-18x3 1/4" bolt, z-plated	36
3	31-016-062	Bracket, frame	12	7	31-014-427	Frame, foot rail	2
4	33006	5/16" flat washer, z-plated, USS	72				

Specifications:

Dimensions, capacity and net weight are provided in the following diagrams and table.

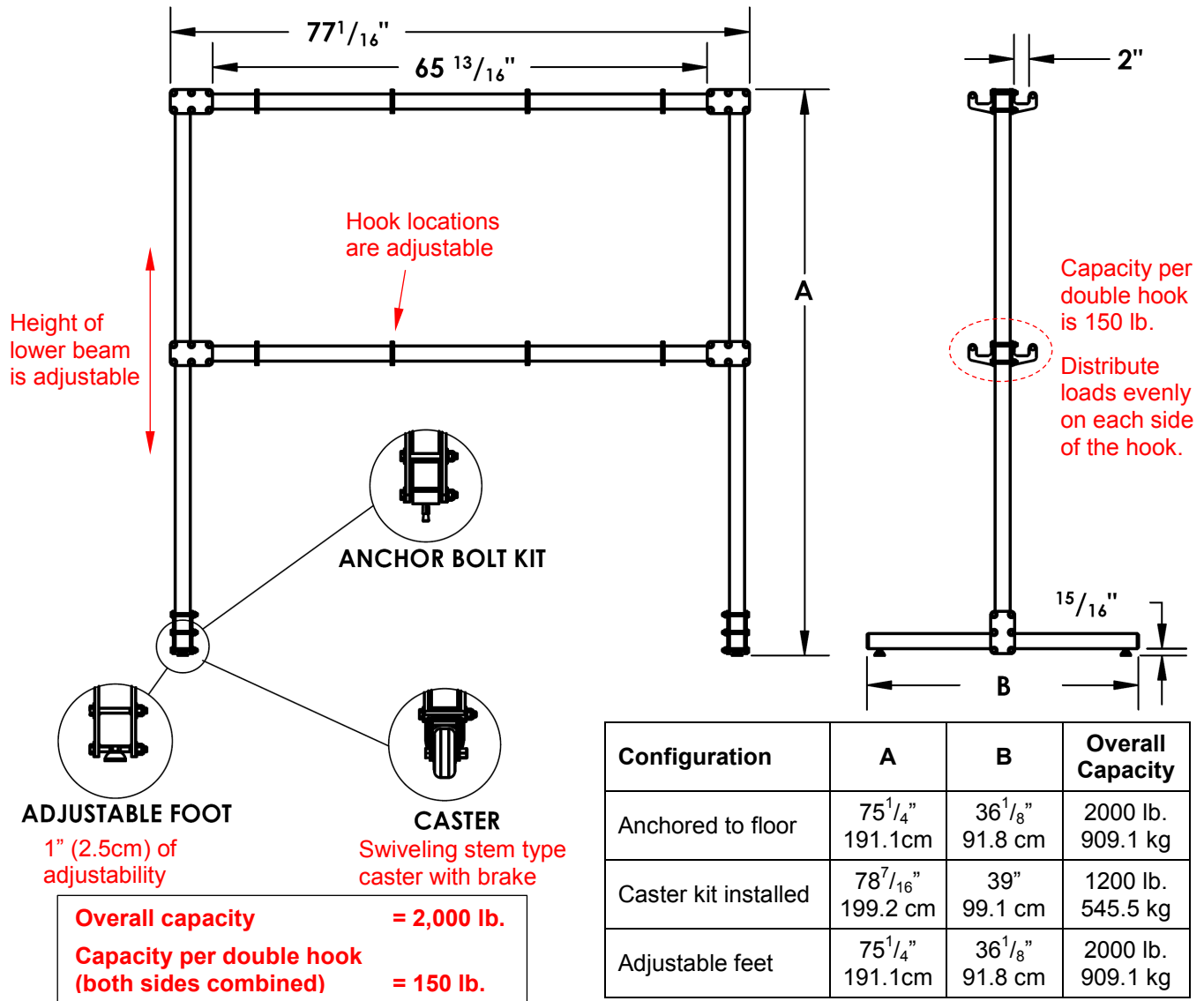

Assembling the rack:

Assembly requires manipulation of heavy components and is best accomplished by 2 or more persons working together. Numbers and letters in parentheses () correspond to item numbers in the diagrams on p. 3.

- Loosely fasten pairs of rail brackets (3) with ⁵/₁₆" hardware: bolts (6), washers (4), and lock nuts (5). Each pair of brackets requires 6 bolts, 12 washers, and 6 lock nuts. Put a washer onto each bolt. Feed the bolt through matching holes in the 2 brackets. Put another washer on the end of the bolt followed by a lock washer. Assemble all 6 pairs of brackets in this manner.

NOTE: If you ordered the hook lock option, **SLR-LS**, see [Hook Lock Option SLR-LS on p. 9](#). Only assemble 5 pairs of brackets as shown in this diagram. The remaining pair of brackets must be assembled as shown in [Step 1 on p. 9](#).

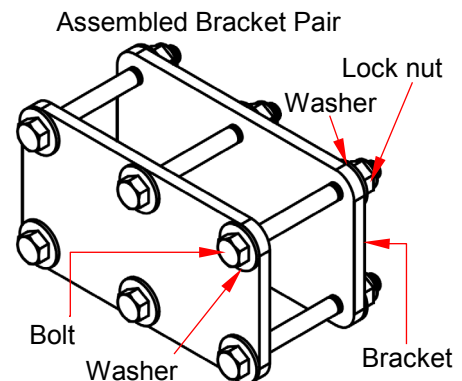

2. There are 4 rails (1) that are about 6ft. (183cm) long. Select 2 of them. Slide 2 bracket pairs onto each rail as shown in the diagram. These rail assemblies form the sides of the rack.
NOTE: If you are installing rack lock option SLR-LS, the bracket pair at the middle of one rail (circled) should be the assembly made in [Step 1 on p. 9](#).

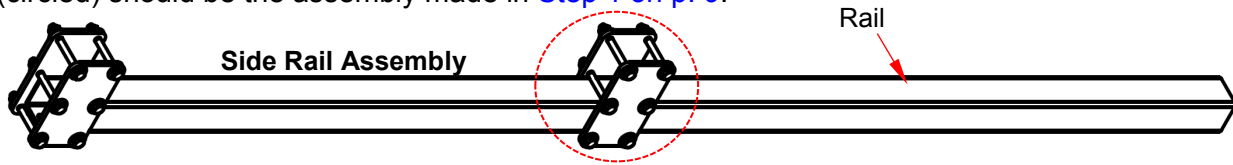

3. Assemble 2 foot rail assemblies. There are 2 foot rails (7) that are approximately 3ft. long. Each foot rail has two holes in one side. Orient the foot rails with holes down. Slide a bracket pair to the center of each foot rail. Attach the desired support feature (adjustable feet; casters; or anchor bolts) to both ends of each foot rail by inserting the features through the holes and securing them with $\frac{3}{8}$ " hardware. Cover the ends of the foot rails with square caps (B). Use a rubber mallet to tap the caps into place.

Foot Rail Assembly

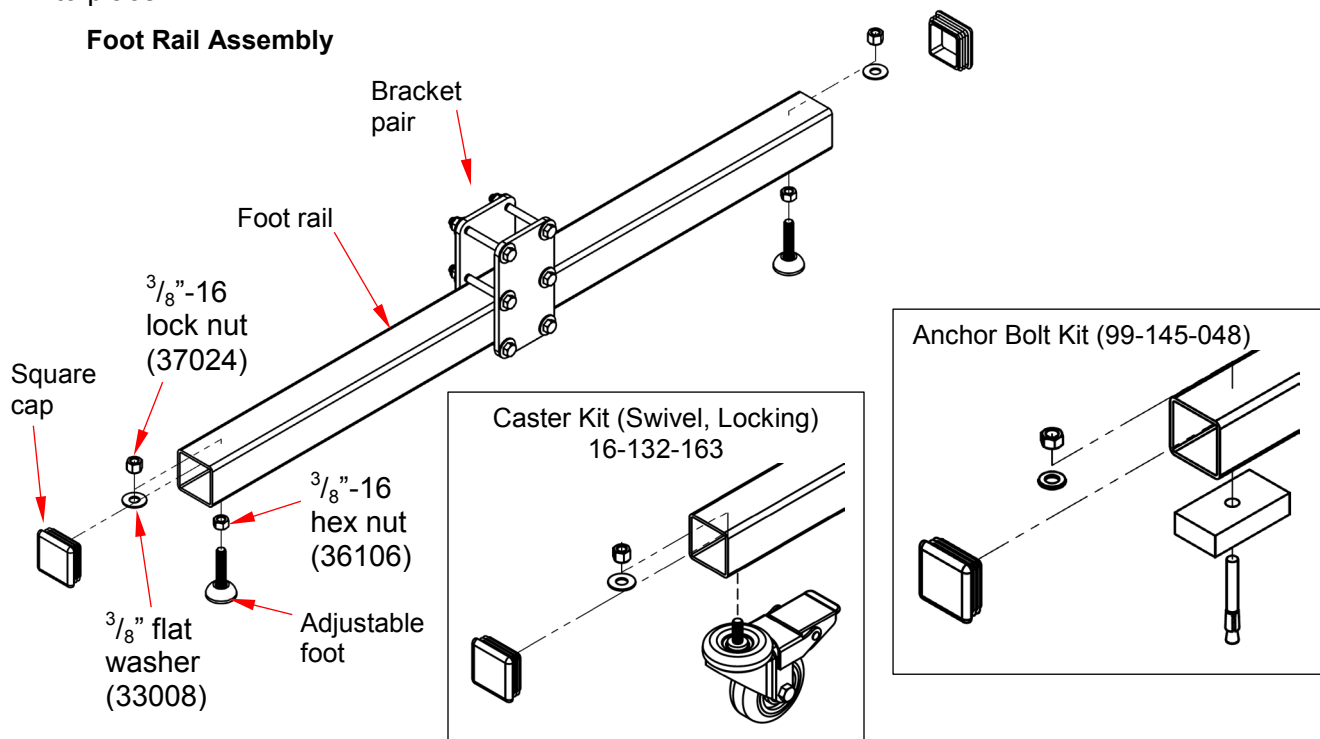

4. Assemble 2 cross rails. There are a total of 4 rails. Bracket pairs were put on the first 2 rails in step 2 (above). Slide 4 double-sided hooks (2) onto both of the remaining rails.
NOTE: If you are installing rack lock option SLR-LS, you must also complete [Step 4 on p. 9](#).

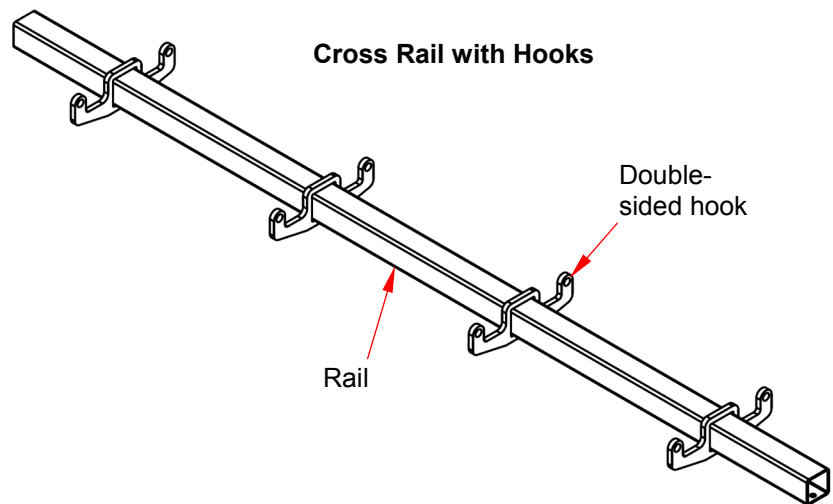

5. Attach the cross rails to the side rail assemblies. Insert the ends of the cross rails into the open ends of the bracket pairs on the side rails. Adjust the locations of the brackets as desired. Brackets should be adjusted to the same locations on both side rails. Tighten all bracket fasteners (bolts and nuts). Brackets should not be able to slide and cross rails must be securely clamped in the brackets.

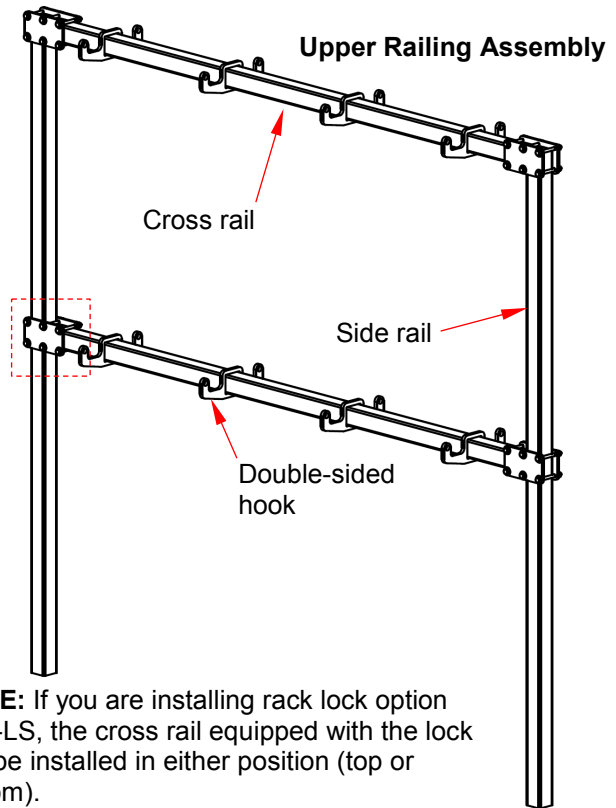
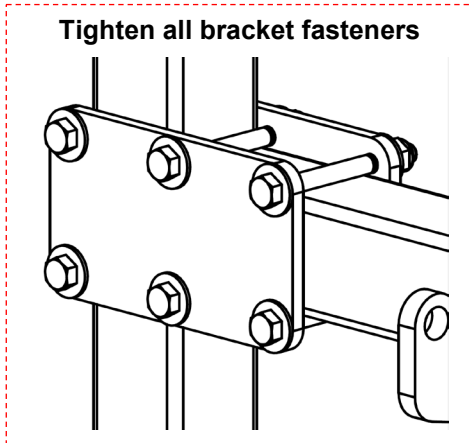

NOTE: If you are installing rack lock option SLR-LS, the cross rail equipped with the lock can be installed in either position (top or bottom).

6. Attach the upper railing assembly completed in step 5, to the foot rail assemblies from step 3. Make sure that brackets are located at the centers of the foot rails. Insert the lower ends of the side rails into the foot rail brackets. Tighten the bracket fasteners.

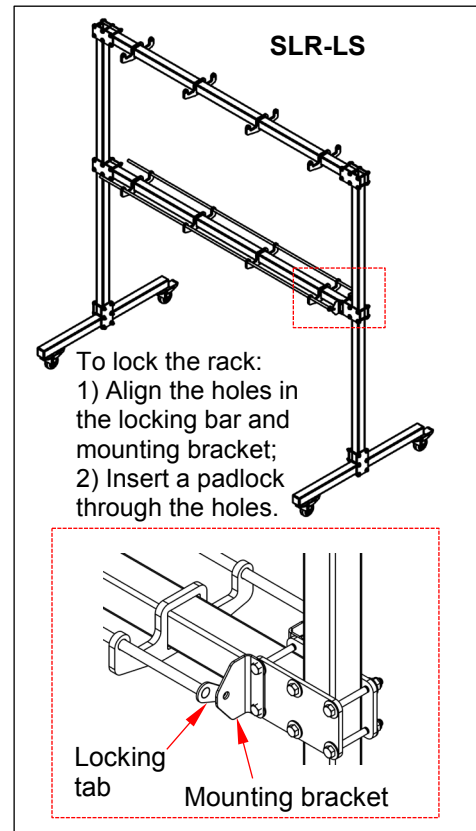
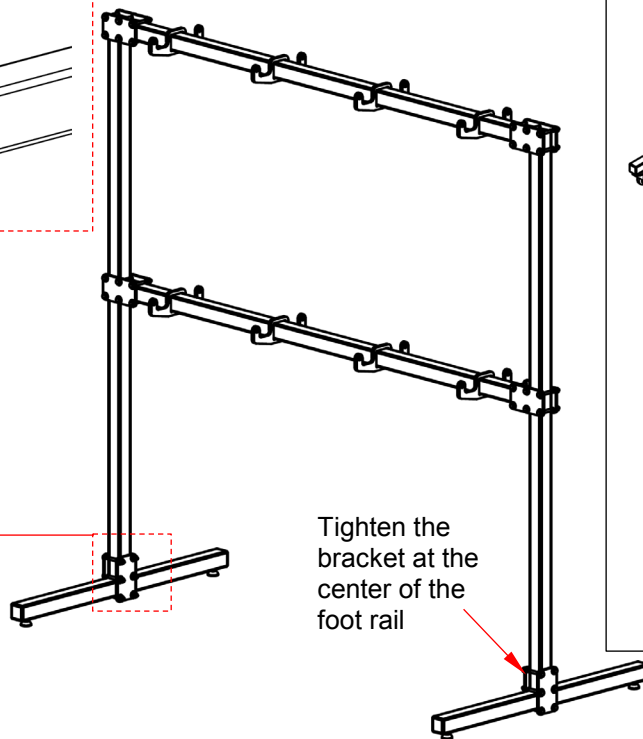
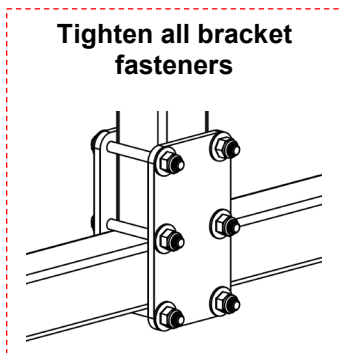

Using the Rack:

Review the capacity information provided in Specifications on p. 4. Weight applied to the cross rails must be evenly distributed across their entire lengths as well as on both sides. Move the hooks so that they are equally spaced from the center of each cross rail. Apply loads to the hooks on the lower cross rail first. Begin with the hooks closest to the center of the cross rails. Apply equal weight to each side of the double-sided hooks.

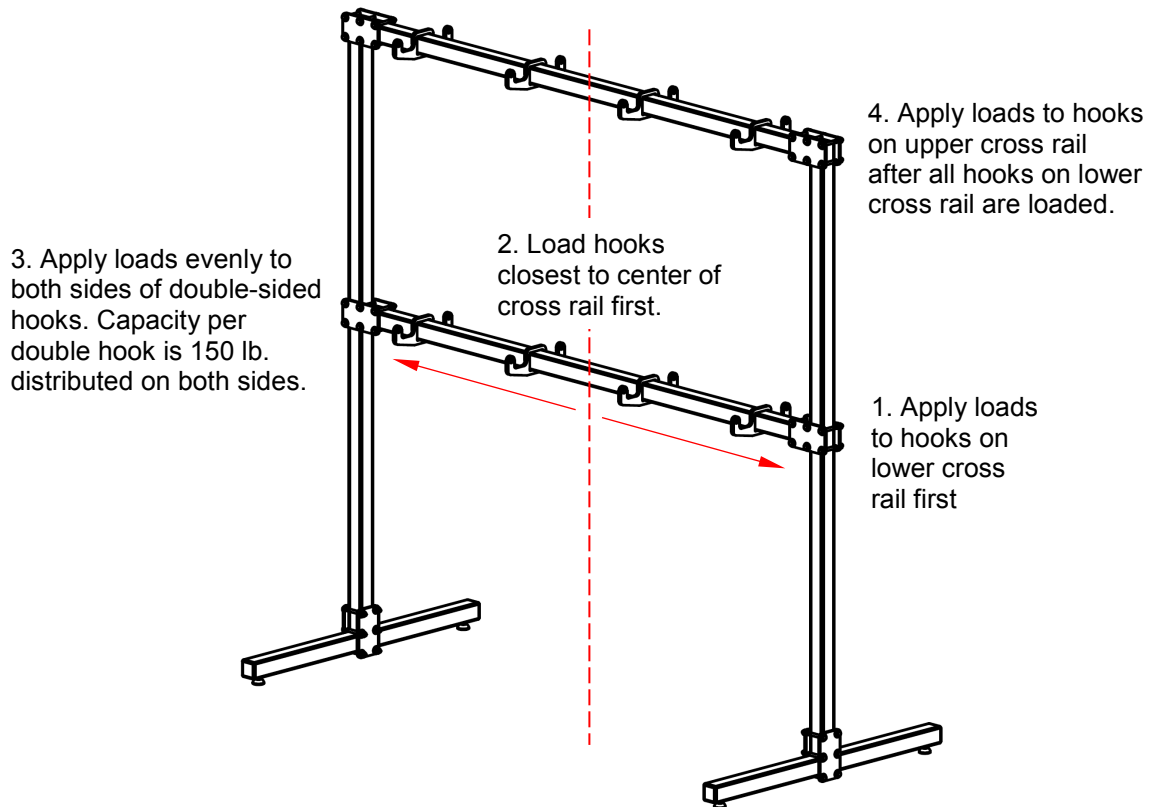

Record of Satisfactory Condition (the “Record”):

Before putting the rack into regular service, make a record that describes its appearance. Thoroughly photograph the assembled unit. Photograph each bracket pair and hook on both sides. Include pictures of all labels applied to the product. This record provides documentation of the rack in satisfactory condition. When performing an inspection described in *Inspections & Maintenance*, compare your findings to this record. If a part is not in satisfactory condition, replace it. Purely cosmetic changes, e.g. damaged finish, do not constitute changes from satisfactory condition. However, touchup paint should be applied to all areas where the finish is damaged as soon as the damage occurs. Contact *Technical Service* to order replacement parts.

Inspections & Maintenance:

Inspect the rack at least once per month. Compare your observations to the *Record*. Replace all parts that are not in satisfactory condition.

1. Hardware/fasteners: Examine all nuts, bolts and washers. Tighten loose connections.
2. Hooks: Inspect every hook for cracks, bends, warps, etc.
3. Side Rails and Cross Rails: Look for cracks, warps, and bends. Remove rust and corrosion. Apply touchup paint wherever the finish is damaged.
4. Bracket pairs: make sure that all bracket pairs solidly clamp to their rails. Examine the material around bolt holes for cracks, thinning regions, elongations, rust, and corrosion. Remove all rust and corrosion. Periodically adjust the locations of the brackets that clamp cross rails to side rails to prevent rust accumulation.

5. Foot rail assemblies: closely inspect the support feature (adjustable feet, casters, or anchors) connections to the foot rails. Tighten loose connections. Examine the material around the holes in the foot rails for cracks, bends, warps, etc. Holes should not be elongated. Both rails should be square and straight. Examine the rails for bends, cracks, and severe rusting and corrosion. Remove rust and corrosion. Apply touchup paint wherever the finish is damaged.
6. Entire/assembled rack: The rack should be level, plumb, and square.
7. Labels: Every label shown in the *Labeling Diagram* (below) must be in place, undamaged, and easily readable.

Labeling diagram:

Each unit should be labeled as shown in the diagram. However, label content and location are subject to change so your product might not be labeled exactly as shown. Compare this diagram to your *Record of Satisfactory Condition*. If there are differences between actual labeling and this diagram, adapt the diagram to reflect actual labeling. Replace all labels that are damaged, missing, or not easily readable (e.g. faded). To order replacement labels or to inquire whether your unit is properly labeled, contact the technical service and parts department online at http://www.vestilmfg.com/parts_info.htm or by calling (260) 665-7586 and asking for the Parts Department.

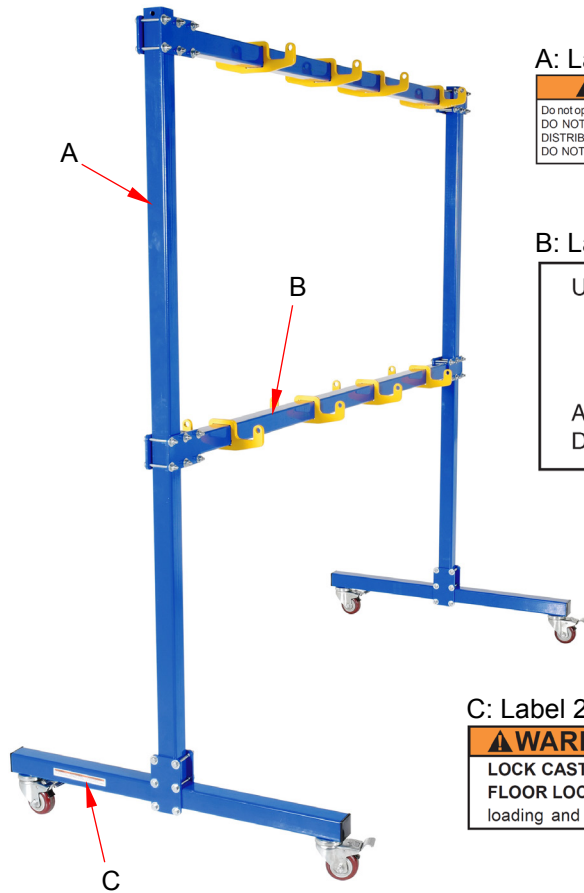

A: Label 658

⚠ WARNING	⚠ ADVERTENCIA	⚠ AVERTISSEMENT
Do not operate or move with unstable loads DO NOT LOAD beyond rated capacity DISTRIBUTE LOAD EVENLY DO NOT sit or ride	No use a mueva con cargas inestables No cargue mas de la capacidad tasada DISTRIBUYA LA CARGA A NIVEL NO SE SIENTE o vaya en el carro	Ne pas utiliser avec une charge instable NE PAS CHARGER au-delà du débit nominale DISTRIBUER la charge régulièrement NE PAS VOUS ASSEoir OU VOUS PROMENER sur le chariot

B: Label 1061

Uniform capacity of rack varies with configuration	1061
Caster kit installed:	1,200 lb. (545.5 kg)
Adjustable feet installed:	2,000 lb. (909.1 kg)
Anchored to floor with bolt kit:	2,000 lb. (909.1 kg)
Capacity per (yellow) hook pair:	150 lb. (68.2 kg)
ALWAYS evenly distribute loads between hook pairs. Distribute loads evenly across each beam. Load bottom beam first.	

C: Label 212

⚠ WARNING	⚠ ADVERTENCIA	⚠ AVERTISSEMENT
LOCK CASTER and/or FLOOR LOCK when loading and unloading	La RUEDECILLA de la CERRADURA y/o el PISO CIERRAN al cargar y descargar	LOCK CASTER et/ou SOL LOCK lors du chargement et de déchargement

Hook Lock Option SLR-LS:

If you ordered the hook lock option, Step 1 and 4 of the assembly instructions on pages 4-6 are slightly different. Complete the following steps along with the installation instructions on pages 4-6. Numbers in parentheses () correspond to item numbers in the diagrams on p. 3. Letters in parentheses correspond to items in the exploded view and bill of materials below.

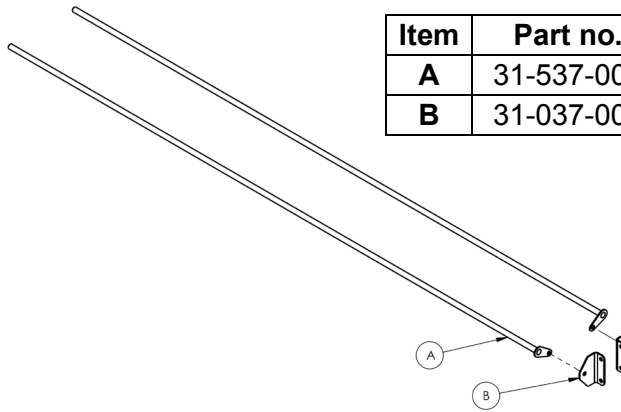

Item	Part no.	Description	Qty.
A	31-537-001	Weldment, lock bar	2
B	31-037-005	Lock, mounting bracket	2

Step 1: Five pairs of rail brackets were assembled in Step 1 on p. 4. To install the rack lock option, the last pair of rail brackets must be assembled with mounting brackets. Loosely fasten the rail brackets (3) with ⁵/₁₆" hardware: bolts (6), washers (4), and lock nuts (5).

Hardware required: 6 bolts, 12 washers, and 6 lock nuts.

- Put a washer onto 4 bolts. Feed the bolts through matching holes in the 2 brackets. Put another washer on the end of each bolt followed by a lock nut.
- Align flat washers with the remaining holes.
- Align the bolt holes in the mounting brackets with the washers.
- Insert bolts through the holes. Apply lock nuts to the ends of the bolts.

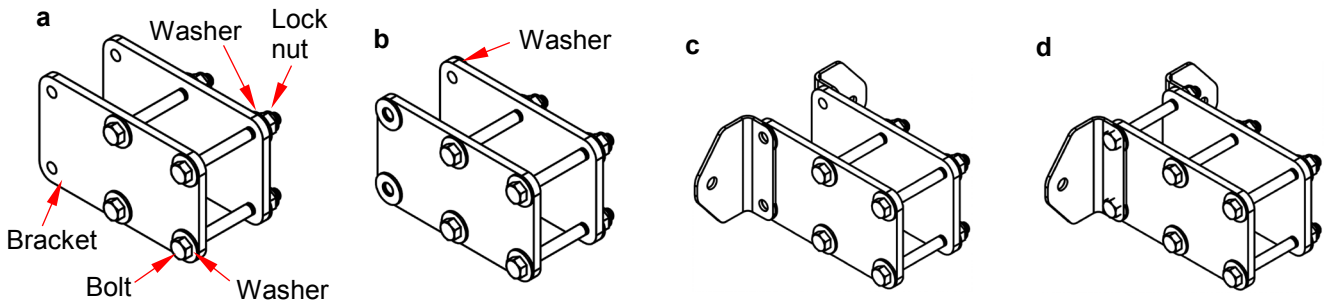

Step 4: Slide the lock bars through the holes in the double-sided hooks. Be sure that the locking tabs of both lock bars are on the same end of the rail.

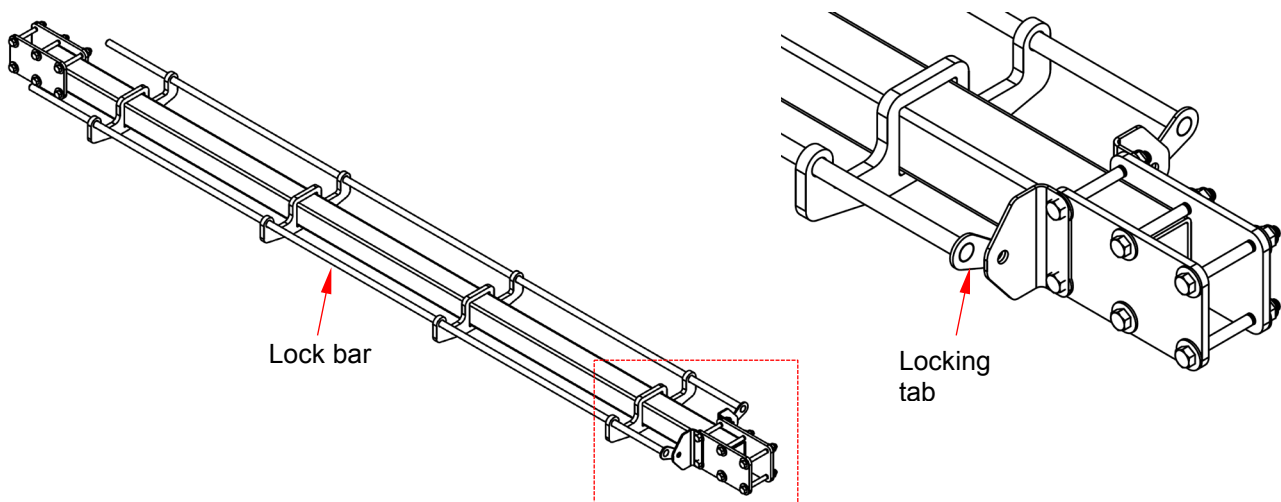

LIMITED WARRANTY

Vestil Manufacturing Corporation (“Vestil”) warrants this product to be free of defects in material and workmanship during the warranty period. Our warranty obligation is to provide a replacement for a defective, original part covered by the warranty after we receive a proper request from the Warrantee (you) for warranty service.

Who may request service?

Only a warrantee may request service. You are a warrantee if you purchased the product from Vestil or from an authorized distributor AND Vestil has been fully paid.

Definition of “original part”?

An original part is a part used to make the product as shipped to the Warrantee.

What is a “proper request”?

A request for warranty service is proper if Vestil receives: 1) a photocopy of the Customer Invoice that displays the shipping date; AND 2) a written request for warranty service including your name and phone number. Send requests by one of the following methods:

<u>US Mail</u>	<u>Fax</u>	<u>Email</u>
Vestil Manufacturing Corporation 2999 North Wayne Street, PO Box 507 Angola, IN 46703	(260) 665-1339 <u>Phone</u> (260) 665-7586	info@vestil.com Enter “Warranty service request” in subject field.

In the written request, list the parts believed to be defective and include the address where replacements should be delivered. After Vestil receives your request for warranty service, an authorized representative will contact you to determine whether your claim is covered by the warranty. Before providing warranty service, Vestil will require you to send the entire product, or just the defective part (or parts), to its facility in Angola, IN.

What is covered under the warranty?

The warranty covers defects in the following original, dynamic parts: motors, hydraulic pumps, motor controllers, and cylinders. It also covers defects in original parts that wear under normal usage conditions (“wearing parts”), such as bearings, hoses, wheels, seals, brushes, and batteries.

How long is the warranty period?

The warranty period for original dynamic components is 90 days. For wearing parts, the warranty period is 90 days. Both warranty periods begin on the date Vestil ships the product to the Warrantee. If the product was purchased from an authorized distributor, the periods begin when the distributor ships the product. Vestil may, at its sole discretion, extend a warranty period for products shipped from authorized distributors by up to 30 days to account for shipping time.

If a defective part is covered by the warranty, what will Vestil do to correct the problem?

Vestil will provide an appropriate replacement for any *covered* part. An authorized representative of Vestil will contact you to discuss your claim.

What is not covered by the warranty?

The Warrantee (you) is responsible for paying labor costs and freight costs to return the product to Vestil for warranty service.

Events that automatically void this Limited Warranty.

- Misuse;
- Negligent assembly, installation, operation or repair;
- Installation/use in corrosive environments;
- Inadequate or improper maintenance;
- Damage sustained during shipping;
- Collisions or other accidents that damage the product;
- Unauthorized modifications: Do not modify the product IN ANY WAY without first receiving written authorization from Vestil.

Do any other warranties apply to the product?

Vestil Manufacturing Corp. makes no other express warranties. All implied warranties are disclaimed to the extent allowed by law. Any implied warranty not disclaimed is limited in scope to the terms of this Limited Warranty. Vestil makes no warranty or representation that this product complies with any state or local design, performance, or safety code or standard. Noncompliance with any such code or standard is not a defect in material or workmanship.

