

OPERATION & SERVICE MANUAL

S SERIES STACKER WITH POWER DRIVE & POWER LIFT



Vestil Manufacturing Corp.

2999 North Wayne St., Angola, IN 46703

Ph: 260-665-7586 . Fax: 260-665-1339

E-mail: Sales@vestil.com

Website: www.vestil.com

CONTENTS

General	3
Specification	4
Receiving instructions	5
Safety Notes	6
Product description	7
Designated use	7
Signs on the Stacker	8
Removing From the Pallet	9
Operation	10
Operation	11
Operating elements	11
Safety elements	12
Driving, braking and horn.....	13
Lifting and lowering	14
Traveling	15
Lifting the load.....	16
Maintenance and repair	17
Trouble shooting	17-21
Changing batteries	22-23
Changing motor controller	24-30
Belly switch trouble shoot	31-48
Maintenance daily/before use, monthly, annually	49
Maintenance and care of the load chains	50
Chain inspections	51
Temporary lay-up	52
Warranty	53
Parts List	54-60

Introduction

Read and follow the instructions contained in this operating manual.

Only trained, well-informed personnel, who have been instructed in accordance with this operation manual, may use or work on the stacker.

Liability or guarantee is waived if:

- The instructions in this operating manual are not observed.
- The high-lift stacking truck is operated, cleaned or maintained incorrectly.
- Alterations to the functions are carried out without the consent of manufacturer.
- Original spare parts are not used.

Safety instructions

This chapter informs the user about residual dangers relating to the correct use of the products. It contains generally valid safety instructions which must be observed.

Safety instructions relating to specific actions or situations are listed prior to the respective action and/or description of the situation in the chapter.

Principles

This product complies with state-of-the-art technical standards and recognized safety regulations, but there are still dangers which may occur which must be considered.

Only operate the product in a perfect condition and observing the information contained in the operating manual.

The operator is responsible for integrating the product with as little risk as possible into his working environment. This obligation continues through every phase of the products lifespan, beginning at the planning stage. Residual dangers are to be minimized.

Only trained, competent personnel who have been instructed using the operating manual and the product are permitted to work with the truck.

The operating manual must be understood (responsibility, checking)

Declaration:

I have read this manual and, in particular, have taken note of the caution.

Name	Date	Signature

Stacker, Motorized, Electric, Cap 2000 Lbs

Powered drive / powered lift pallet stacker truck. Raise, lower and maneuver loads quickly and easily. An easy-to-operate thumb-wheel allows infinite forward and reverse travel speeds of 3.8 mph unloaded / 3.1 mph loaded. Fingertip raise and lower buttons, horn and a safety-reverse control-button are conveniently located. An electromagnetic disc brake with automatic dead-man feature activates when the user releases the handle. Two, 12 volt, 70 amp-hour batteries, integral charger, charge-level indicator and emergency disconnect are included. Features 24 volt DC 0.7 KW drive and 2.0 KW lift motors. Out-rigger wheels keep the stacker stable when turning. The rigid frame features perimeter toe-skirting. Protective mesh on the operator side of mast is powder-coated black allowing see-through visibility. A proprietary DC motor controller prevents unsafe starts when the safety-reverse button is inadvertently struck. Adjustable forks are forged-metal, fixed forks are formed-metal, all have a 55" turning radius. Rolls smoothly on polyurethane steer and load wheels. Deep cycle batteries typically provide eight (8) hours of service on one full charge.

		S-62-FF	S-62-AA	S-62-FA	S-118-FF	S-118-AA
Capacity		2000 lbs.	2000 lbs.	2000 lbs.	2000 lbs.	2000 lbs.
Fork Lift Height		62"	62"	62"	118"	118"
Fork Dimension		42x5.9x2 3/8"	42x4x1-1/4"	42x5.9x2 3/8"	42x5.9x2 3/8"	42x5.9x2 3/8"
Overall fork width		26-3/4"	26-3/4"	26-3/4"	26-3/4"	26-3/4"
Ground Clearance		1"	1"	1"	1"	1"
Lowered Fork H.		3-3/8"	2-1/8"	2-9/16"	3-3/8"	2-1/8"
H. Overall Extended		81-7/8"	82-11/16"	81-7/8"	81-7/8"	82-11/16"
Head Dimension		26-1/2x30x29-3/4"	26-1/2x30x29-3/4"	26-1/2x30x29-3/4"	26-1/2x30x29-3/4"	26-1/2x30x29-3/4"
Loading Center		23-5/8"	23-5/8"	23-5/8"	23-5/8"	23-5/8"
Wheel Base		44-11/16"	45-7/16"	44-11/16"	44-11/16"	45-7/16"
Turning Radius		55"	55"	55"	55"	55"
Support Wheel		Φ4x2"	Φ4x2"	Φ4x2"	Φ4x2"	Φ4x2"
Front Wheel		Φ3-1/8x3-3/8"	Φ2.9x4"	Φ3-1/8x3-3/8"	Φ3-1/8x3-3/8"	Φ2.9x4"
Drive Wheel		Φ10x3-1/8"	Φ10x3-1/8"	Φ10x3-1/8"	Φ10x3-1/8"	Φ10x3-1/8"
Overall Size		68x30x82	69x46-3/16x82-11/16"	68x46x82	68x30x82	69x46-3/16x82-11/16"
Lift	Load	3.23"/s	3.23"/s	2.95"/s	5.9"/s	5.9"/s
Speed	Unload	5.46"/s	5.46"/s	5.9"/s	7.86"/s	7.86"/s
Lower Speed	Load	2.4"/s	2.4"/s	4"/s	3.93"/s	3.93"/s
	Unload	2"/s	2.48"/s	2"/s	3.57"/s	3.57"/s
Travel Speed	Load	3.1 m/h	3.1 m/h	3.1 m/h	3.1 m/h	3.1 m/h
	Unload	3.8 m/h	3.8 m/h	3.8 m/h	3.8 m/h	3.8 m/h
Drive Motor		24V/700W	24V/700W	24V/700W	24V/700W	24V/700W
Lift Motor		24V/2.0KW	24V/2.0KW	24V/2.0KW	24V/2.0KW	24V/2.0KW
Controller		1207A-4102	1207A-4102	1207A-4102	1207A-4102	1207A-4102
Battery		2x12V/70Ah	2x12V/70Ah	2x12V/70Ah	2x12V/70Ah	2x12V/70Ah
Battery Charger		DC 24V/6A	DC 24V/6A	DC 24V/6A	DC 24V/6A	DC 24V/6A
Weight		950 lbs.	990 lbs.	970 lbs.	1091 lbs.	1131 lbs.
Min Width of Aisle		35-1/2"	52"	52"	52"	52"

Note: The load capacity is based on the situation when the center of the gravity is located at the center of length of forks. When the center of gravity of goods is out of the center of forks, the load capacity will be lessened compared to the center.

Receiving Instructions

Every unit is thoroughly tested and inspected prior to shipment. However, it is possible that the unit may incur damage during transit. If you see damage when unloading, make a note of it on the SHIPPER RECEIVER.

Remove all packing & strapping material, inspect for damage. IF DAMAGE IS EVIDENT, FILE A CLAIM WITH THE CARRIER IMMEDIATELY! Also, check fork size, type of power unit, etc., to see that the unit is correct for the intended application.

Warnings & Safety Instructions

Insure that all employees understand and follow the following instructions

- Read and understand the owner's manual before using or servicing the stacker.
- Do not use the stacker if any damage or unusual noise is observed.
- Improper use of this lift truck could result in injury and damage to load or equipment.
- Always watch the stacker and any load on it carefully when it is being used or moved.
- DO NOT load beyond rated capacity.
- DISTRIBUTE load evenly.
- Avoid sudden stops or quick turns to prevent accidental tipping of the load.
- Load must be centered and evenly distributed on the forks.
- Park the truck on level surfaces and not in the way of other products
- When parked, lower the load fork completely.
- When parked, push E-switch push-button down.
- Do not perform any modifications to the stacker without the manufacturer's approval. Failure to receive authorization for changes to the equipment could void the warranty.
- Do not use brake fluid or jack oil in the hydraulic system. If oil is needed, use an anti-wear hydraulic oil with a viscosity grade of 150 SUS at 100°F, (ISO 32 @ 40°C), or a non-synthetic transmission fluid.
- Use only replacement parts either supplied or approved by the manufacturer.

Safety notes

Symbols and pictures

In addition to the text and illustrations, this operating manual contains various symbols which should draw attention to the safety requirements.











They generally have the following appearance:

Signal wording	Explanation
DANGER	Warning of an imminent danger! Non-observance cause death or serious injury
WARNING	Warning of a possibly incoming dangerous situation. Non-observance may cause death or serious injury.
CAUTION	Warning of a possibly incoming dangerous situation. May also be used for warnings of major damage to property.

Other definitions:

DIRECTION	Marks recommendations for use and other useful information. Does not warn of dangerous situations.
IMPORTANT	Warns of a harmful situation. Non-observance may cause damage to material.

USE SYMBOLS & PICTURES

	Possible danger to file and limb or machine!		Do not step onto when load is raised!
	Danger of crushing!		It is forbidden to ride on the truck!
	Do not reach into running motor!		Suspension points for transport of truck!
	Wear safety shoes		Important
	Wear helmet		Suspended warning! load

Product description

Designated use

- ❖ The stacker is designated for lifting, lowering and transportation of loads according to the specifications of the identification plate.
- ❖ The stacker is to be used on hard level surfaces.
 - To move the stacker between buildings, warehouses etc
 - The gradient of the slope must not be more than 10%
 - Make sure load is not loose or unstable.
 - Do not pick up loads on tips or forks or edge of platform.
 - Do not overload.
 - The road surfacing must be solid and have a good grip.
- ❖ Travel routes must offer sufficient load-bearing capacity for the loaded truck.
- ❖ The stacker is not suitable for continuous use in cool-houses!

Ambient conditions				
Temperature	From To	14 113	° F ° F	
Degree of humidity		≤70	%	
Permitted floor incline				
• Loaded		Max. 0.5	%	
• Unloaded ¹		Max. 2.0	%	
Dimensions and weights				
Mass (dead weight)	m	1058/1653	lbs	



WARNING!

The user is responsible for determining the actual load bearing capacity of a high-lift stacking truck. This can depend on the user, the condition of both the floor and the high-lift stacking truck and the regularity of the maintenance intervals.

Product description

Signs on the truck



Removing from the pallet



CAREFUL

To pick up the unit only use overhead hoist, or forklift with sufficient carrying capacity & take into consideration the center of gravity of the unit. Use top crossmember to lift the equipment. Be careful of the stacker swinging once fully lifted off the pallet or skid. Remove the pallet or skid from below the lift & lower the stacker on the ground.

Refer to the identification plate for the weight of stacker.



Lifting belt specification— Use polyester lifting sling or nylon sling and hoist with a minimum of 2,000 lb. capacity.



DANGER

When unloading the truck, all personnel should be cleared from the area.

OPERATION

Visually inspect stacker for damaged and worn parts, before stacker is taken into operation. Authorized person should read and understand all instructions

The lifting truck is ready for immediate use once the packaging has been removed.

- ◆ The battery is full and charged.
- ◆ The hydraulic tank is full.
- ◆ The driving gear is filled with oil filling for approx. 200 operation hours.
- ◆ The steering roller and the running rollers are equipped with bearings which do not require maintenance; all mast rollers are also free from maintenance.



Caution!

Pedestrian controlled industrial trucks may only be operated by persons who have been satisfactorily instructed in operating the truck and have proved their ability to operate the truck to the responsible representative of the operating company.

The first driving attempts should take place on level and spacious surfaces.

Recommendation:

The operator who is to maneuver the truck and is to control the lifting mechanism should be allowed to practice, when unloaded, until they can safely operate these functions. Only then should they undertake the loading, transporting and unloading of load.

Operation

Operating elements

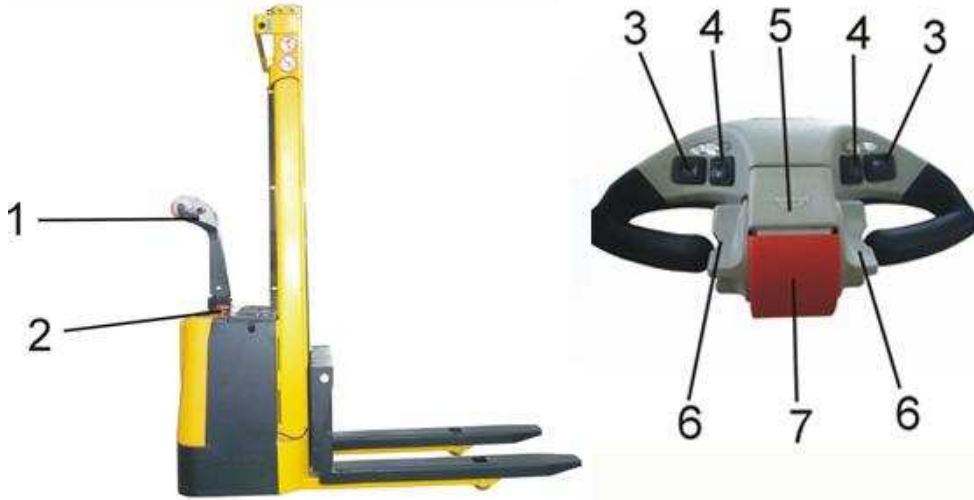

Operating elements

- 1.Handle
- 2.Emergency Stop
- 3.Lift up
- 4.Low down
- 5.Horn
- 6.Forward / backward switch
- 7.Back-run safety device button
- 8.Key switch
- 9.Power metre



Operation



Safety elements:

If the red panic button at the tiller head is actuated, this switches over briefly to reverse motion and then stops the truck movement.



If travel or lift movements cannot be stopped with the operating elements, hitting the emergency stop switch will interrupt the entire power supply.



Operation



Driving

- Pull up the red push button of the E-switch
- Tilt the Control handle to driving position, the locking brake is released
- If you release Control handle, this returns to the vertical start position, the truck brakes and the locking brake activates
- The truck is steered via the Control handle

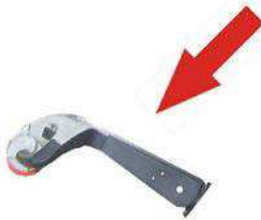

- 1 = upper braking range
- 2 = travelling range
- 3 = lower braking range



Brake:

This stacker is equipped with a magnetic brake that is applied between 10-15 degrees of the vertical position and between 85 -90 degrees of the lower position in the vertical operating of the handle. The brake can be operated at any point in the lateral operating of the handle. When you release your hand from the handle, it will resume neutral position automatically, and will activate the brake. Always make sure that the brake is in work before operating the stacker. When parked, always put the handle in the full vertical position with the brake applied and forks lowered.

Horn:

A horn is located on top of the handle.



To raise and lower

The following are generally valid for the lifting and lowering procedure:

- The red operating button of the EMERGENCY STOP pushbutton must be pulled upwards
- Lifting and lowering movements are initiated by pressing the pushbuttons on the handle head.

There are four buttons located on the two sides of the handle. Each side of the control has one button for raising the forks and one button for lowering the forks. Always make sure when lifting that the load is within the capacity rating of your truck and that the load has been stacked safely on the pallet. Also, make sure that there is no one standing near the forks when raising or lowering. It is also important to make sure that the length of the forks corresponds to the opening in the bottom of the pallet. The load rollers must be placed between boards so when you raise the forks, the pallet will not be broken or damaged. Always make sure when entering the pallet that the forks are in the fully lowered position. Be careful when lifting pallets that are too short or too long for the truck



Warning

It is not allowed to climb or reach into any moving parts of the stacker-e.g. the lifting frame, thrust units, lifting mechanisms etc.

Travel

The butterfly switch controls the direction and speed of the lift truck. Rotating the butterfly control towards the forks moves the truck in the forward direction. Rotating the butterfly control away from the forks, moves the truck in the reverse direction. The control is progressive – the further you rotate the control, the faster the truck will travel.

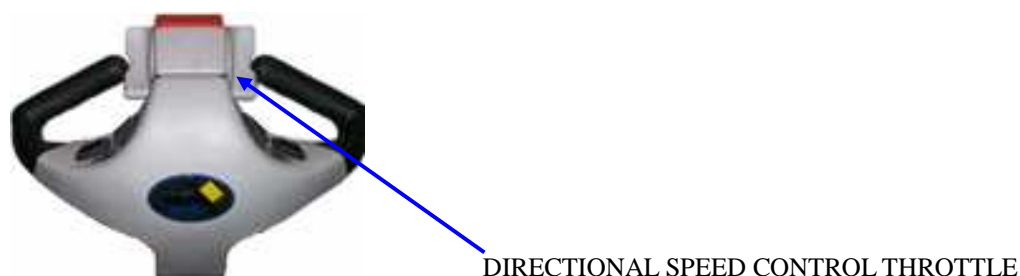

Emergency reverse safety button

At the top of the handle is a red safety reverse button. The button is designed to change the travel direction away from the operator when depressed. The truck will stop moving away from the operator when the button is released. When the fork truck is traveling forward (away from the operator) the button has no effect when activated.

If the belly switch becomes jammed or stuck, it will move forward (away from the operator) for a maximum of 3 seconds at which time the control circuit will become disabled until the handle is re-set to the full up or full down position and the belly switch is returned to normal operation.



Operation

Lifting load



CAUTION!

- Before lifting a load to be transported, ensure that the load does not exceed the carrying capacity of the truck.
- The nominal carrying capacity and lifting heights can be viewed in the load diagram.
- Ensure that the load can be lifted up in a compact and stable manner. Slipping or falling of the load must be avoided.
- The load must not project into the lifting frame.
- The load must be centered and evenly distributed on the forks.
- The load must not project more than 2" over the end of the lifting forks.

Transporting the load



CAUTION!

- Raise the load only slightly to transport
- For safety reasons (view) transport only in a forward direction
- Only when lifting up or lowering down the load it is permissible to drive stacker forward or in reverse with a raised load
- Lift up or lower down loads on level surfaces
- When unloaded, move stacker only with forks lowered

Maintenance and repair

TROUBLESHOOTING GUIDE --

Warning: Before performing any task, always block drive wheel off of the ground.

Consult the factory for problems at time of installation, or for any problems not addressed below.

<u>Problem:</u>	<u>Possible cause(s):</u>	<u>Action:</u>
Unit doesn't move when controls are used.	Battery voltage low (<17) Problem with motor controller (check for LED flash code on side of controller) Fuse blown	Charge batteries. Consult diagnostics page/factory Remove back shroud and check fuses (3 fuses).
Unit will not charge	Charger malfunction Bad batteries	Verify output voltage on charger, will only get a reading when connected to batteries; should be approximately 28 volts. Load test batteries
Unit will not go forward; reverse works; belly switch just kills unit (does not go forward and time out)	Broken wire, or loose connection Contactor bad, motor controller bad	Locate Pin 2 on Molex connector at motor controller. Trace wiring to contactor and verify connection. When forward is depressed, there should be 24 volts on this wire from Molex connector to the contactor, if not, the motor controller may be bad; consult diagnostics page/factory. If 24 volts is present at contactor, verify ground connection. If ground is good, remove both wires and check with ohm meter; resistance should be approximately 38 ohms. If it's open or zero, the contactor should be replaced.
Unit will not go reverse; belly switch works (i.e. when the handle is in operating range and rotating throttle in reverse and the belly switch is hit, the unit moves forward and times out)	Broken wire, or loose connection, contactor bad, motor controller bad	Same as above; except locate Pin 3 on Molex connector on motor controller...and follow procedure.

<u>Problem:</u>	<u>Possible cause(s):</u>	<u>Action:</u>
Unit will not go forward, or reverse, but belly switch still functions properly.	Broken wire, or loose connection, bad motor controller, Throttle assembly bad	Locate Pin 6 on Molex connector at the motor controller. Try to drive the unit in forward, there should be 0 to 5 volts (5 v is full throttle) at this pin. If there is voltage and the unit does not move, the motor controller may be bad, consult diagnostics page/factory. If there is no voltage, trace the wiring back towards the tiller head and check voltage on each side of connectors. Continue this until bad connection is found. If the connections are all good, and there is no voltage coming out of throttle assembly, then the throttle assembly may be bad. Verify there is 24 volts going into the assembly and that there is a good ground. If there is still no output voltage for pin 6, replace throttle assembly. See Fig. 1
Unit will not move forward, or reverse, and the Belly switch will not function, unit does turn on as indicated by the battery gage lighting up.	Blown fuse Broken wire, or loose connection	Verify fuses are good, replace if blown. Locate Pin 7 on Molex connector at the motor controller. Trace wire back up to tiller head and verify continuity all the way to the throttle assembly. Repair any loose connections. If there is continuity up to the throttle assembly, then check the ground wire that comes off of B- on the motor controller (3 rd terminal down). Add more length to this wire if necessary, and re-terminate with a ring terminal.
Unit will not go forward; the belly switch functions; reverse works.	Broken wire, or loose connection, bad motor controller Bad throttle assembly	Locate Pin 11 on Molex connector at the motor controller. Try to drive the unit in forward; there should be 24 volts at this pin. If there is voltage and the unit does not move, the motor controller may be bad, consult diagnostics page/factory. If there is no voltage, trace the wiring back towards the tiller head and check voltage on each side of connectors. Continue this until bad connection is found. If the connections are all good, and there is no voltage coming out of throttle assembly, then the throttle assembly may be bad. Verify there is 24 volts going into the assembly and that there is a good ground. If there is still no output voltage for pin 11, replace throttle assembly. See Fig. 1

<u>Problem:</u>	<u>Possible cause(s):</u>	<u>Action:</u>
Unit will not reverse; belly switch does not function; forward ok	Broken wire, or loose connection, bad motor controller Bad throttle assembly	Locate Pin 12 on Molex connector at the motor controller. Try to drive the unit in reverse; there should be 24 volts at this pin. If there is voltage and the unit does not move, the motor controller may be bad, consult diagnostics page/factory. If there is no voltage, trace the wiring back towards the tiller head and check voltage on each side of connectors. Continue this until bad connection is found. If the connections are all good, and there is no voltage coming out of throttle assembly, then the throttle assembly may be bad. Verify there is 24 volts going into the assembly and that there is a good ground. If there is still no output voltage for pin 12, replace throttle assembly. See Fig. 1
Belly switch does not function; forward ok; reverse ok	Broken wire, or loose connection, bad motor controller Bad belly switch	Locate Pin 13 on Molex connector at the motor controller. Try to drive the unit in reverse, and hit the belly switch... there should be 24 volts at this pin. If there is voltage and the unit does not move, the motor controller may be bad, consult diagnostics page/factory. If there is no voltage, trace the wiring back towards the tiller head and check voltage, or continuity on each side of connectors. Continue this until bad connection is found. If the connections are all good, and there is no voltage, then the switch may be bad. Verify there is 24 volts going into the switch. If there is still no output voltage for pin 13, replace the switch.
Unit will not reverse. The unit only goes forward for about 1 second and dies when the handle is pulled down. When the handle is re-set and pulled down the unit will move forward again then die.	Stuck Switch	The belly switch is stuck on. Tap the orange assembly to see if the switch can be freed. If this doesn't work, disassemble the tiller head by removing 3 screws from bottom. Slightly loosen up the two screws that hold the switch in place, this may free the switch. If it is still stuck, contact the factory for a replacement switch.

<u>Problem:</u>	<u>Possible cause(s):</u>	<u>Action:</u>
Unit will not raise; motor does not run	Loose wire Bad solenoid Upper limit switch out of adjustment Blown fuse Batteries discharged	Verify 24 volts at coil when raise is pushed, if no voltage; trace wiring back to tiller head looking for voltage on each side of the connectors until the bad connection is found. If voltage is present at the solenoid and the unit does not rise, remove the two wires to the coil and measure the coil resistance. It should be around 19 ohms. If it's open, or shorted replace the solenoid. Bypass upper limit switch and see if the unit raises...DO NOT TAKE IT ALL THE WAY UP... If it does rise, verify the limit switch is normally closed and will open when activated. If the limit switch is ok, try to adjust the switch accordingly so that the units raise height is approximately 7 to 8" Check fuses above motor controller Re-charge batteries
Unit will not raise; motor runs	Lower solenoid stuck on No hydraulic oil	Check to see if the lowering switch is stuck on. If it is, remove the tiller head via 3 screws on bottom and replace switch, or tap on switch to see if it can be freed up. Re-fill hydraulic oil
Unit will not lower	Loose wire; bad coil Upper limit switch out of adjustment	Verify 24 volts at coil when lower is pushed, if no voltage, trace wiring back to tiller head looking for voltage on each side of the connectors until the bad connection is found. If voltage is present at the coil and the unit does not lower, remove the connector to the coil and measure the coil resistance. It should be around 39 ohms. If it's open, or shorted replace the coil. Loosen hydraulic line at pump to relieve pressure build up. Re-adjust limit switch so unit stops at 7 to 8 inches above the ground. Look for binding in chain or rollers
Unit keeps blowing fuses when the raise button is pressed	Shorted solenoid for motor raise	Remove the wire to the solenoid coil on the pump motor. Measure the resistance; it should be around 19 ohms. If it is nearly zero ohms replace the solenoid.

<u>Problem:</u>	<u>Possible cause(s):</u>	<u>Action:</u>
Unit will not reverse; belly switch does not function; forward ok	Broken wire, or loose connection, bad throttle assembly, bad motor controller.	Locate Pin 12 on Molex connector at the motor controller. Try to drive the unit in reverse; there should be 24 volts at this pin. If there is voltage and the unit does not move, the motor controller may be bad, consult factory. If there is no voltage, trace the wiring back towards the tiller head and check voltage on each side of connectors. Continue this until bad connection is found. If the connections are all good, and there is no voltage coming out of throttle assembly, then the throttle assembly may be bad. Verify there is 24 volts going into the assembly and that there is a good ground. If there is still no output voltage for pin 12, replace throttle assembly.
Lifting height is not longer achieved	Hydraulic oil level is too low	Re-fill hydraulic oil when forks are lowered.
Unit jerks when lifting	Air in the system	Open vent screw on the lift cylinder with forks lowered all the way down. Lift forks with vent screw open until oil is free from air bubbles. Close the vent screw
Forks raise, then drift down	Check valve or Solenoid valve leaking (contamination holding open the lowering valve or the check valve)	Remove & inspect. . Remove any load from the forks. . Remove the nut holding solenoid coil on the valve stem, and then unscrew the valve from the manifold. . Inspect the valve for contaminants, and the valve's o-rings and back-up washers for cuts, tears, and other damage. . With valve immersed in mineral spirits or kerosene, use a thin tool such as a small screwdriver or a small hex wrench to push the poppet in and out several times from the bottom end of the valve. The valve should move freely, about 1/16" from closed to open position. If it sticks in, the valve stem could be bent and will need to be replaced if it doesn't free up after cleaning. Blow the valve off with a compressed-air gun while again pushing the poppet in and out.

Instructions for Changing the Batteries, estimated time, 15 min.

READ ALL INSTRUCTIONS BEFORE PROCEEDING!

Only qualified personnel should work on this equipment!

Lock out all potential energy sources before attempting this installation; turn off the unit and remove the key.

Warning!

- ! Working with or near lead acid batteries is dangerous. Batteries contain sulfuric acid and produce explosive gases. A battery explosion could result in loss of eyesight or serious burns.
- ! Do not smoke or allow a spark or flame near batteries. Charge batteries in locations which are clean, dry, and well-ventilated. Do not lay tools or anything metallic on top of any battery. All repairs to a battery must be made by experienced and qualified personnel.
- ! When working with batteries, remove personal items such as rings, bracelets, necklaces, and watches. Batteries can produce enough energy to weld jewelry to metal, causing a severe burn.
- ! Always have fresh water and soap nearby in case battery acid contacts skin, clothing, or eyes.
- ! Operating the battery with a low battery voltage can cause premature motor contact failure.
- ! Do not expose the lift or charger to rain or adverse conditions.
- ! Replace defective cords or wires immediately.
- ! Check the battery's water level frequently if this applies to your battery type.
- ! Make sure the battery charger is unplugged from 115vac source.

Battery Charger Operating Instructions

Plug the charger into a standard 115V receptacle. If an extension cord must be used, keep it as short and as large as possible. A small cord will decrease the output of the charger due to the voltage drop in the line. This will increase the charging time. It can also cause the 115V cord to overheat.

When properly connected, the charge LED will indicate the status of charge current flowing to the battery, as follows: Power LED is always green when charger is plugged in. The status light is as follows:

Red only – the charger is providing full output to the battery.

Yellow – the charger is “topping off” the battery.

Green – the charger is providing a “float,” or maintenance, charge.

Remember to unplug the charger before moving the equipment. Failure to do so could cause damage to cords, receptacles and other equipment.

Troubleshooting:

If the unit does not operate, check all of the wiring connections to make sure they're both mechanically and electrically sound – specifically at the battery, and the motor.

A fully-charged lead acid battery in good condition at room temperature should read 12.65 volts. At 11.9 volts it is considered to be fully discharged and in need of charging. When checking battery voltage, wait at least 1\2 hour after the charger has been turned off before checking the battery's voltage.

If the batteries aren't being charged by the charger, check the output charger fuse. Verify fuse is good with an ohmmeter, or close visual (ohm meter best). Fuse is a 10Amp 250 Volt; GBD 10A. If it is good, check the battery's state of charge with a voltmeter. The charger must be connected to the battery in order to read the output voltage of the battery charger. Depending on the state of charge of the batteries, the voltage should be somewhere around 27 to 28 volts dc.

If it is determined the batteries are dead, and need replaced, change the batteries.

Tools Required:

14mm wrench, or crescent wrench
Regular flat bladed screw driver

Instructions; Changing the Motor Controller in; estimated time, 30 min.

READ ALL INSTRUCTIONS BEFORE PROCEEDING!

Only qualified personnel should work on this equipment!

Lock out all potential energy sources before attempting this installation; turn off the unit and remove the key.

Warning!

- ! Working with or near lead acid batteries is dangerous. Batteries contain sulfuric acid and produce explosive gases. A battery explosion could result in loss of eyesight or serious burns.
- ! Do not smoke or allow a spark or flame near batteries. Charge batteries in locations which are clean, dry, and well-ventilated. Do not lay tools or anything metallic on top of any battery. All repairs to a battery must be made by experienced and qualified personnel.
- ! When working with batteries, remove personal items such as rings, bracelets, necklaces, and watches. Batteries can produce enough energy to weld jewelry to metal, causing a severe burn.
- ! Always have fresh water and soap nearby in case battery acid contacts skin, clothing, or eyes.
- ! Operating the battery with a low battery voltage can cause premature motor contact failure.
- ! Do not expose the lift or charger to rain or adverse conditions.
- ! Replace defective cords or wires immediately.
- ! Check the battery's water level frequently if this applies to your battery type.
- ! Make sure the battery charger is unplugged from 115vac source.

Troubleshooting:

If it has been determined the motor controller needs to be replaced, the following procedure can be used.

Tools Required:

2x 14mm wrench, open face

Philips head screwdriver

8mm wrench

Verify power is off to the unit; key switch off!

Remove yellow cover; two screws on top.



The Campro motor controller is shown here.



The wiring must be marked

The wiring should be marked in a unique way to remember where it all goes when re-connecting.

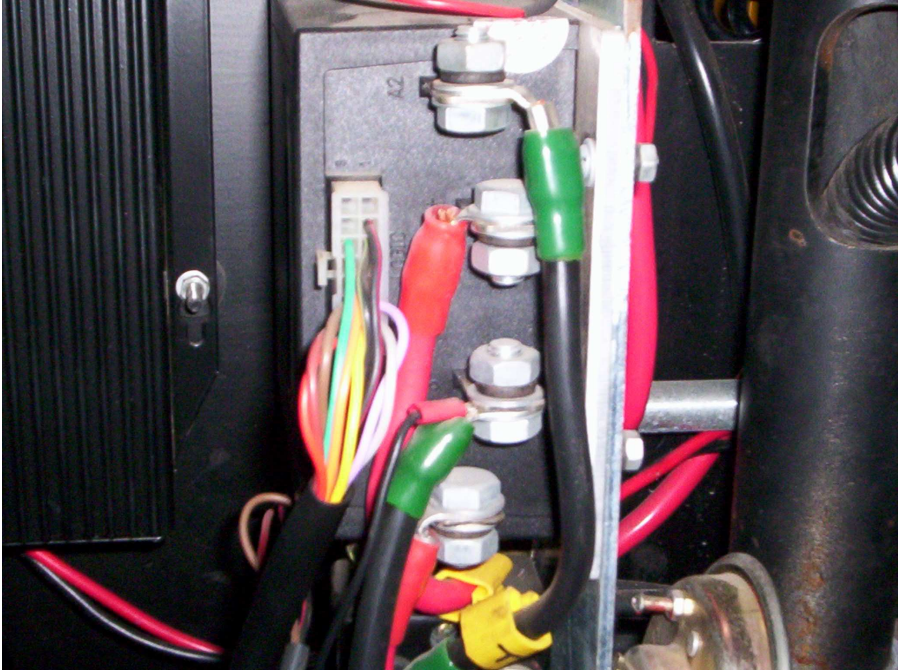

One possible method is shown below.

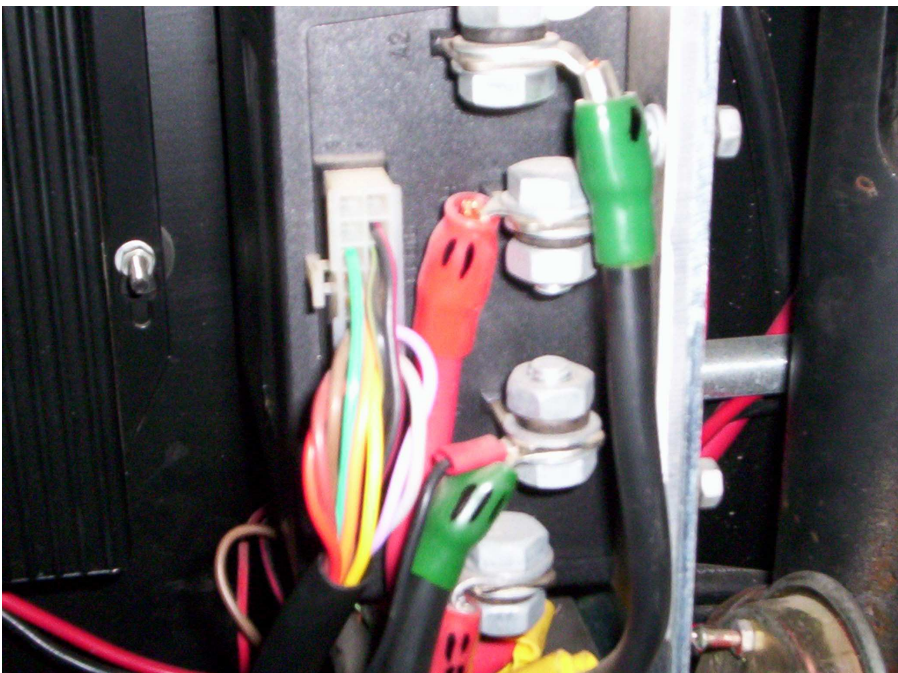

Remove the two 14mm bolts holding the motor controller mounting plate to the frame.

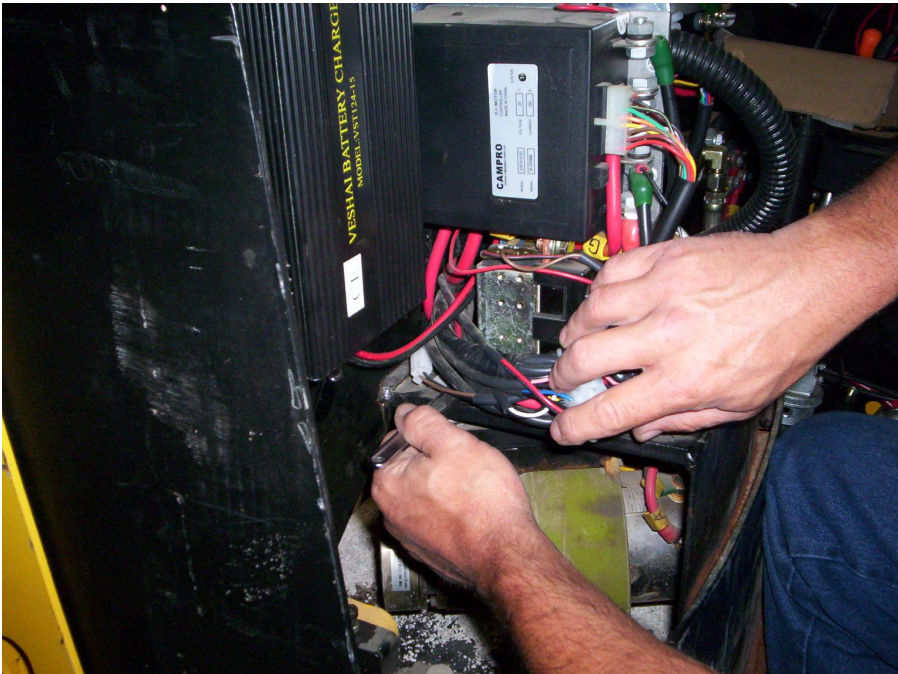

Two bolts, one front and one back.



Remove the Molex connector from the motor controller.

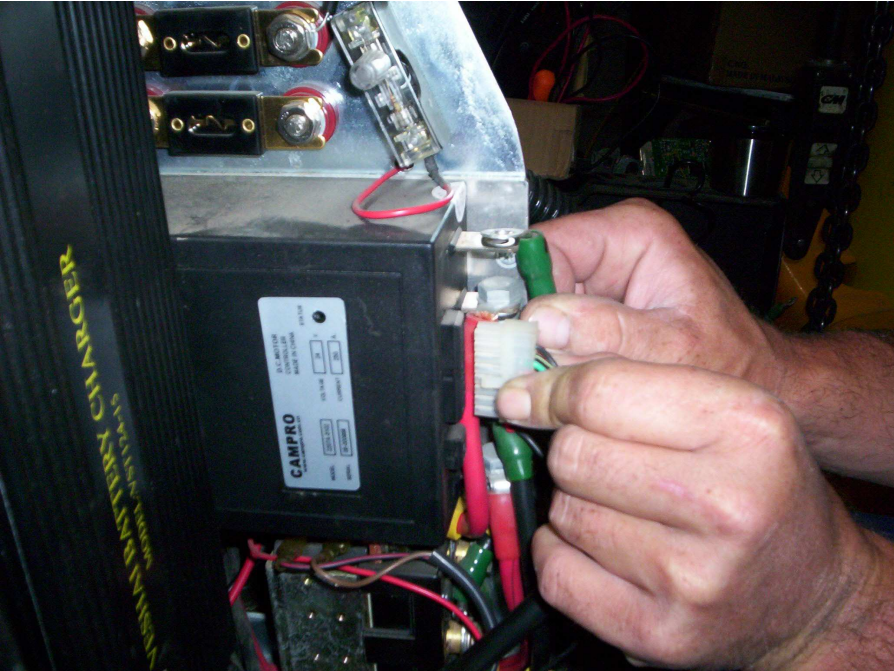

Remove the motor controller wiring with two 14mm wrenches.

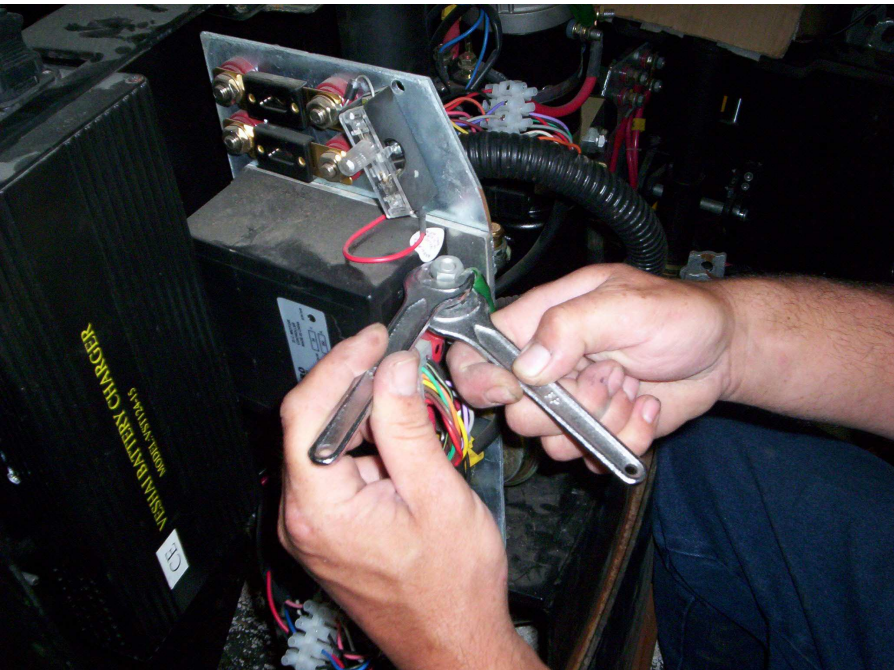

Wiring shown here removed.

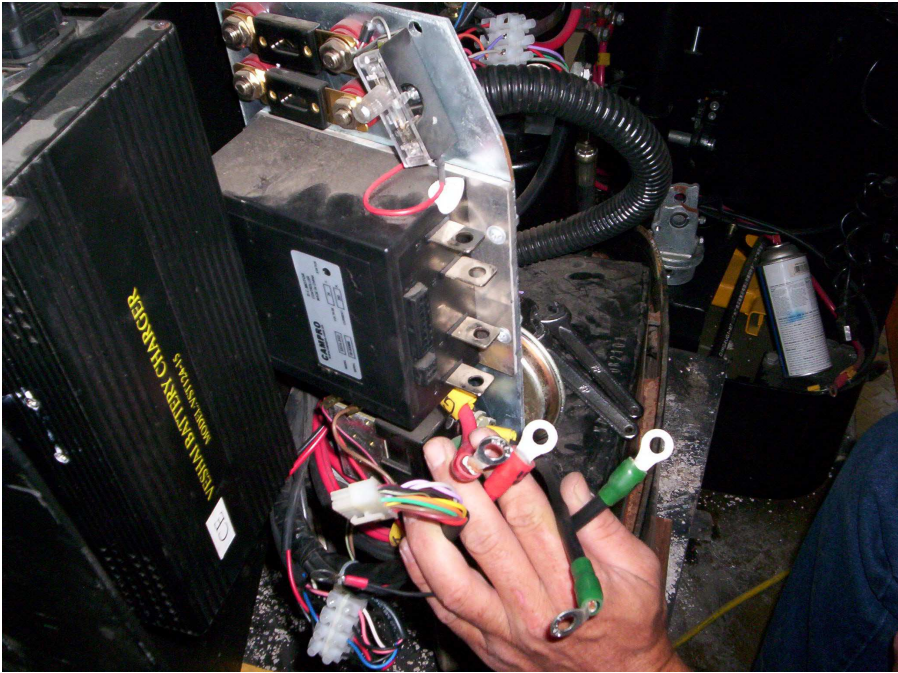

Remove 3x 8mm screws holding the motor controller to the back plate with a Philips screwdriver, and 8mm wrench. 1 screw in back and two in the front.



Remove the motor controller, and replace with a new controller by reversing the above steps.

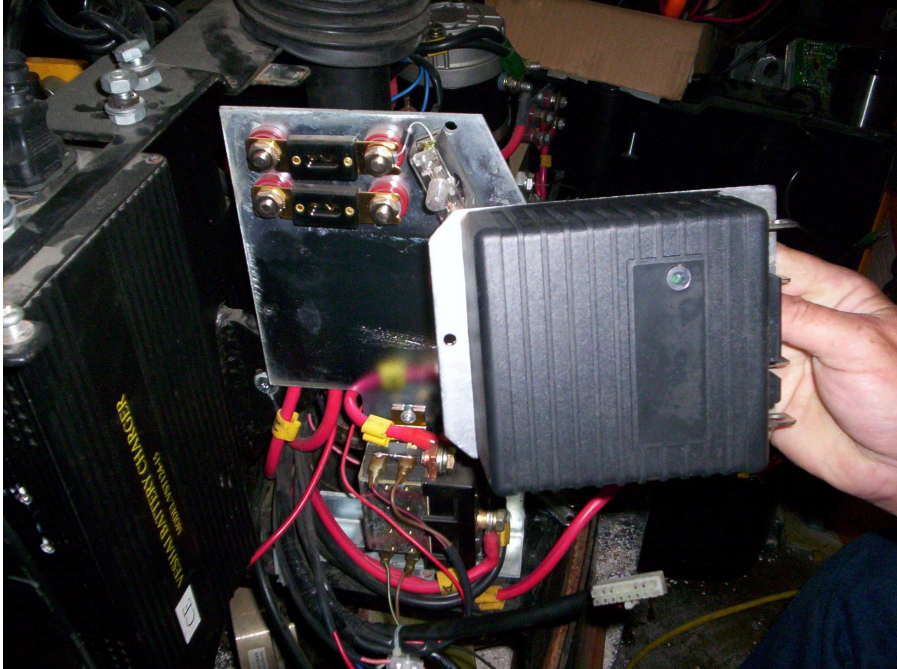

Verify the 4 spade terminal connections are still good on the forward / reverse motor contactor. The contactor is just below the motor controller.

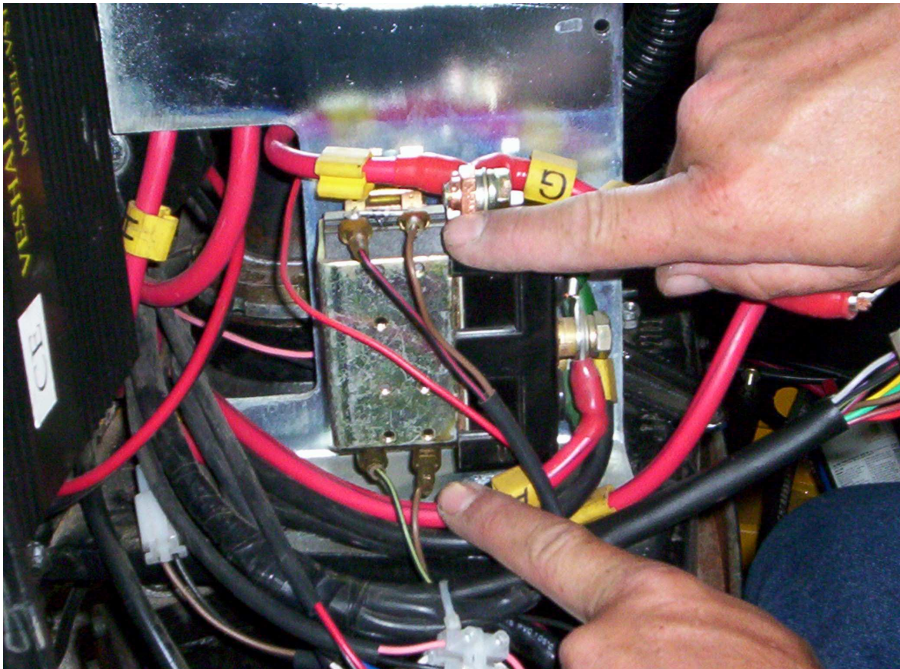

Instructions for Changing the Tiller Assembly; S-62-AA/FF/FA estimated time, 30 min.

READ ALL INSTRUCTIONS BEFORE PROCEEDING!

Only qualified personnel should work on this equipment!

Lock out all potential energy sources before attempting this installation; turn off the unit and remove the key.

Warning!

- ! Working with or near lead acid batteries is dangerous. Batteries contain sulfuric acid and produce explosive gases. A battery explosion could result in loss of eyesight or serious burns.
- ! Do not smoke or allow a spark or flame near batteries. Charge batteries in locations which are clean, dry, and well-ventilated. Do not lay tools or anything metallic on top of any battery. All repairs to a battery must be made by experienced and qualified personnel.
- ! When working with batteries, remove personal items such as rings, bracelets, necklaces, and watches. Batteries can produce enough energy to weld jewelry to metal, causing a severe burn.
- ! Always have fresh water and soap nearby in case battery acid contacts skin, clothing, or eyes.
- ! Operating the battery with a low battery voltage can cause premature motor contact failure.
- ! Do not expose the lift or charger to rain or adverse conditions.
- ! Replace defective cords or wires immediately.
- ! Check the battery's water level frequently if this applies to your battery type.
- ! Make sure the battery charger is unplugged from 115vac source.

Troubleshooting:

If the unit does not operate, check all of the wiring connections to make sure they're both mechanically and electrically sound – specifically at the battery, and the motor.

A fully-charged lead acid battery in good condition at room temperature should read 12.65 volts. At 11.9 volts it is considered to be fully discharged and in need of charging. When checking battery voltage, wait at least 1\2 hour after the charger has been turned off before checking the battery's voltage.

If the batteries aren't being charged by the charger, check the output charger fuse. Verify fuse is good with an ohmmeter, or close visual (ohm meter best). Fuse is a 10Amp 250 Volt; GBD 10A. If it is good, check the battery's state of charge with a voltmeter. The charger must be connected to the battery in order to read the output voltage of the battery charger. Depending on the state of charge of the batteries, the voltage should be somewhere around 27 to 28 volts dc.

If the batteries are fully charged, and the units belly switch is not functioning the following procedure will show how to...

- A) Replace the tiller assembly which contains the belly switch and throttle controls.
- B) Troubleshoot belly switch mechanism itself.

The following tools will be required:

5mm allen wrench
Philips bladed screw driver
Small Regular flat bladed screw driver

S-62-XX; verify this is the unit you are working on.



Make sure E-switch is off (pushed down). Fig.2



This is the top side of the tiller. Fig3



Fig.3

This is the driver side of the tiller, looking at the belly switch. Fig 4



Fig.4

This is the bottom side of the tiller handle. 3 allen head screws need to be removed. Fig5



Fig.5

Lift the front top edge of the tiller cover up. Fig6



Fig.6



Carefully pull the belly switch back off of the tiller while tipping the front up.
Fig 8



Fig.8

The tiller assembly cover should come off, just be careful not to drop it and rip out the wiring from the connectors. At this point, the tiller throttle assembly can be replaced with a new one by just unplugging the two connectors. Or, if the problem appears to be in the belly switch itself, further breakdown of the assembly can continue to search for the problem. Fig 9



Fig.9

Unplug the two connectors from the tiller throttle assembly. Fig10

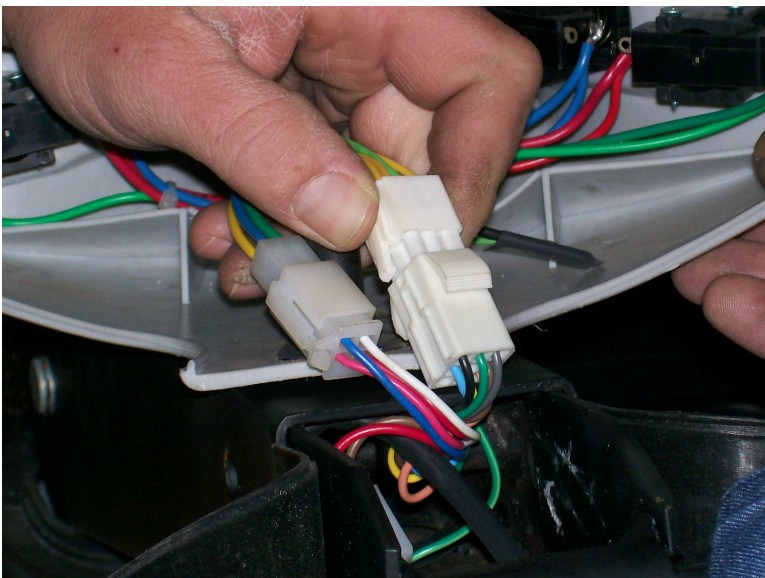

Fig.10

Remove Philips screw on throttle. Fig11



Fig.11

Throttle wheel will then pull off. Take note of the orientation of the wheel on the shaft. Correct orientation is shown here. Fig 12



Fig.12

Do the same on the other side, taking note of the orientation of the two plastic bushings. If the throttle wheel had a tendency to stick, contact Vestil Manufacturing for replacement bushings. Fig 13

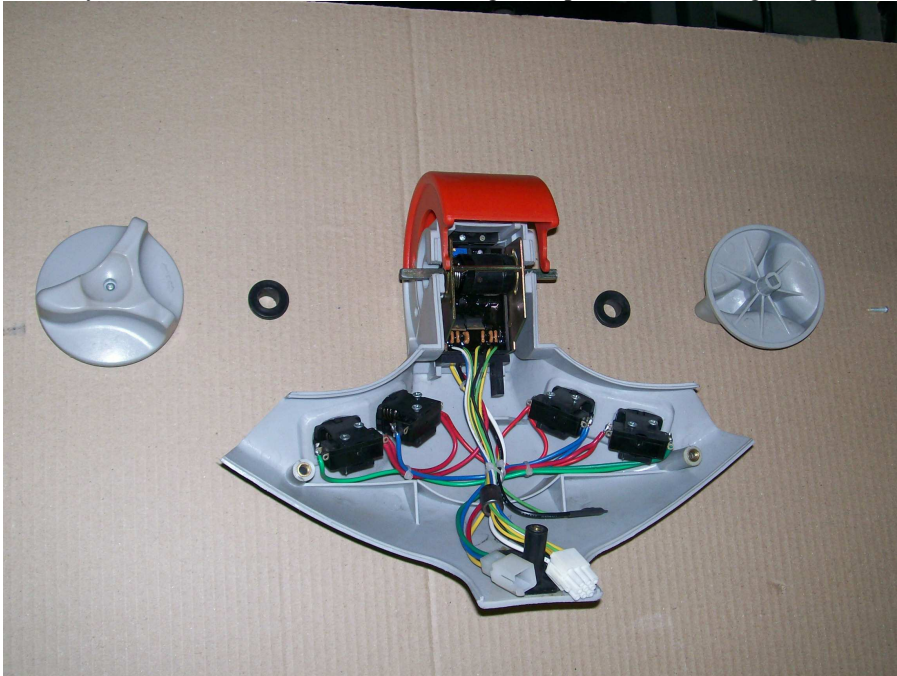

Fig.13

The front of the red cover should be connected via the gray nub. Fig 14



Fig.14

To remove the red cover, use a small screwdriver and carefully lift the plastic up over the gray nub. Fig 15

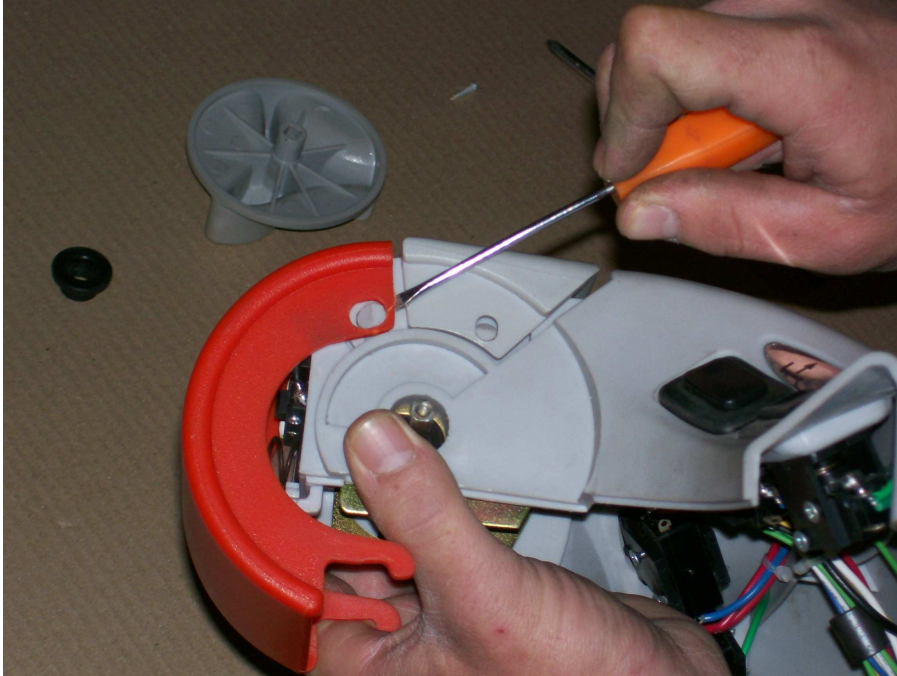

Fig.15

Do the same on the other side, and remove. Fig 16



Fig.16

This should expose a spring. This spring has a specific orientation. When assembled the spring sets in the red cup on the inside of the red belly cover. Fig 17

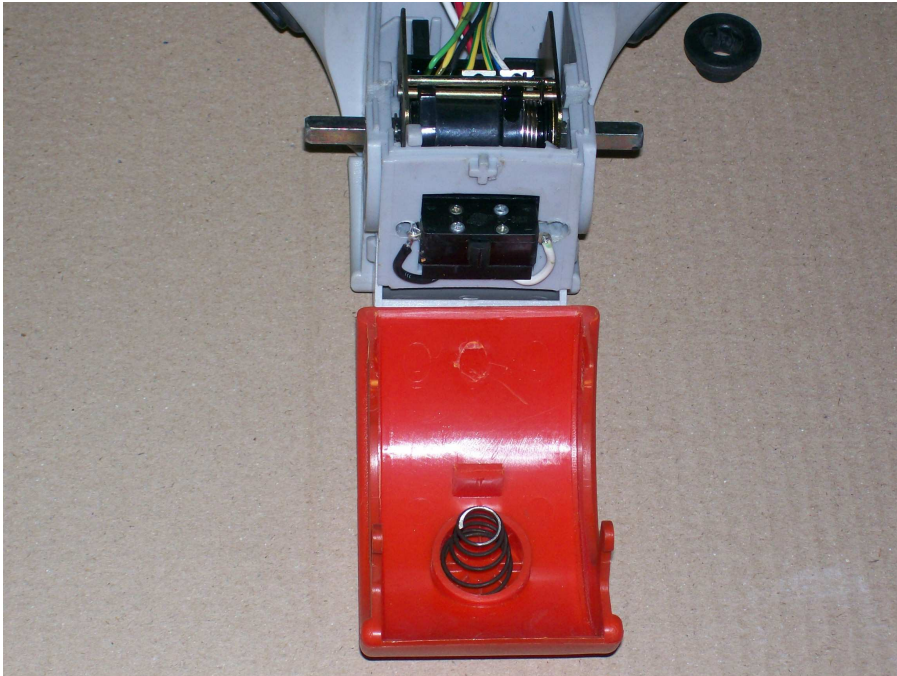

Fig.17

The other side of the spring fits over the gray plastic nub above the switch. Fig 18

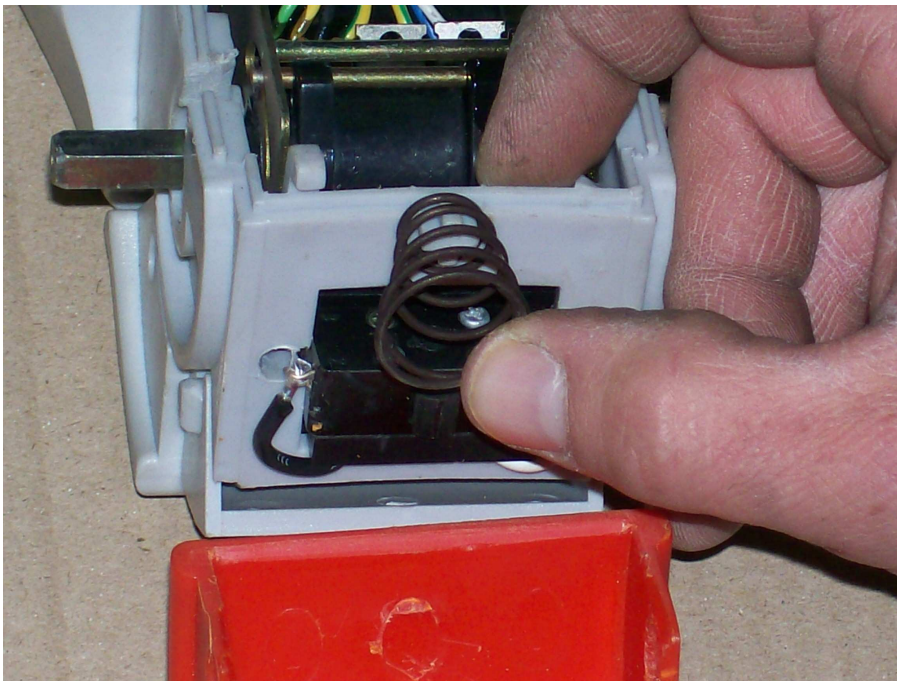

Fig.18

Another picture of the nub, spring not shown. At this point, verify the solder joints are in tact and the two wires are attached to the switch as shown below. Also verify the belly switch is not stuck in. You should be able to push on the switch and the actuator will move freely in and out, you should here a click as you do this. If the switch is stuck in contact Vestil Manufacturing for replacement options. Fig19

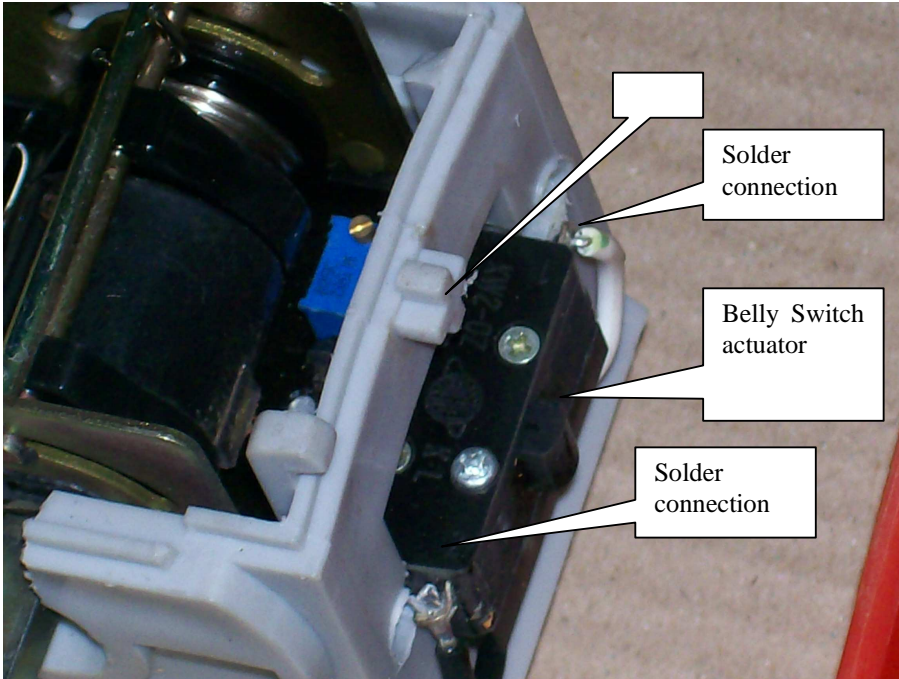

Fig.19

Replace any broken/missing components. To assemble, press the red belly switch cover back on the tiller head seating the red holes over the gray nubs. Basically the opposite of the procedure in Fig. 17, but without a screwdriver. Fig 20



Fig.20

The spring can be pushed into position.
Fig. 21



Fig.21

This is the spring shown not seated completely. Push the spring into the pocket, and over the gray plastic nub. Fig22



Fig.22

Install bushings. Fig23



Fig.23

Put throttle thumb wheels back on. Fig24



Fig.24

Install Philips screw. Fig25

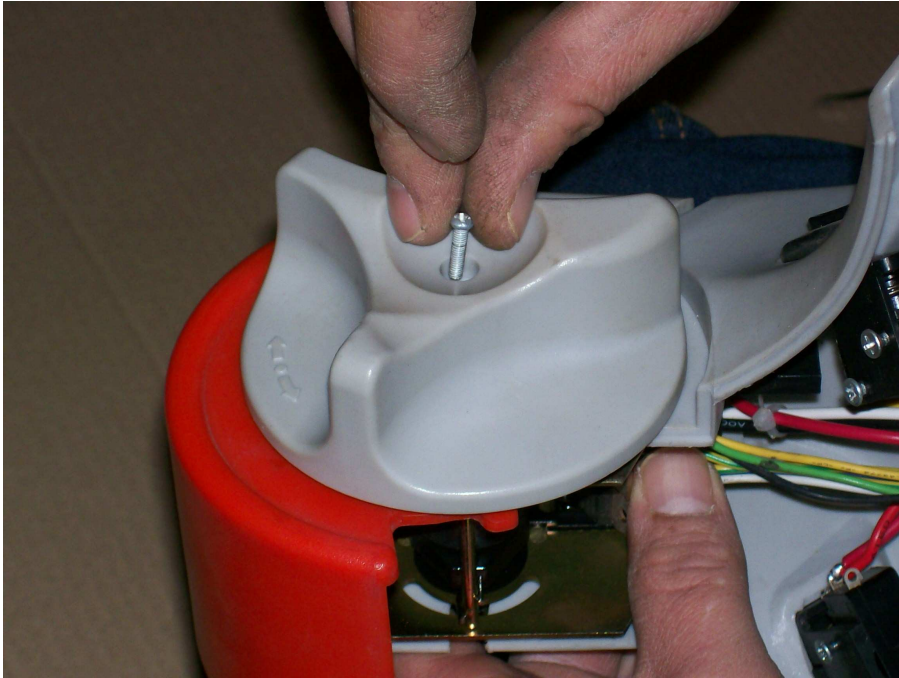
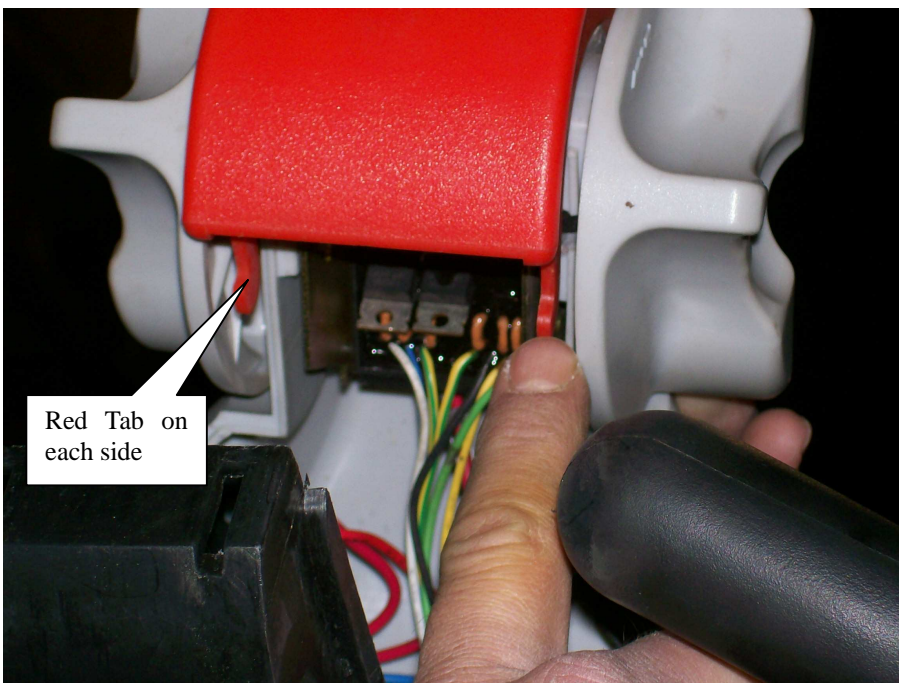

Fig.25

Re-installing the tiller cover is basically reversing steps Fig 5 thru 9; with the following precautions/steps. Make sure red tabs on each side goes on top of black nubs when installing tiller cover on the handle. Fig 26



Black nub for right side shown here; and the next photo Fig 27

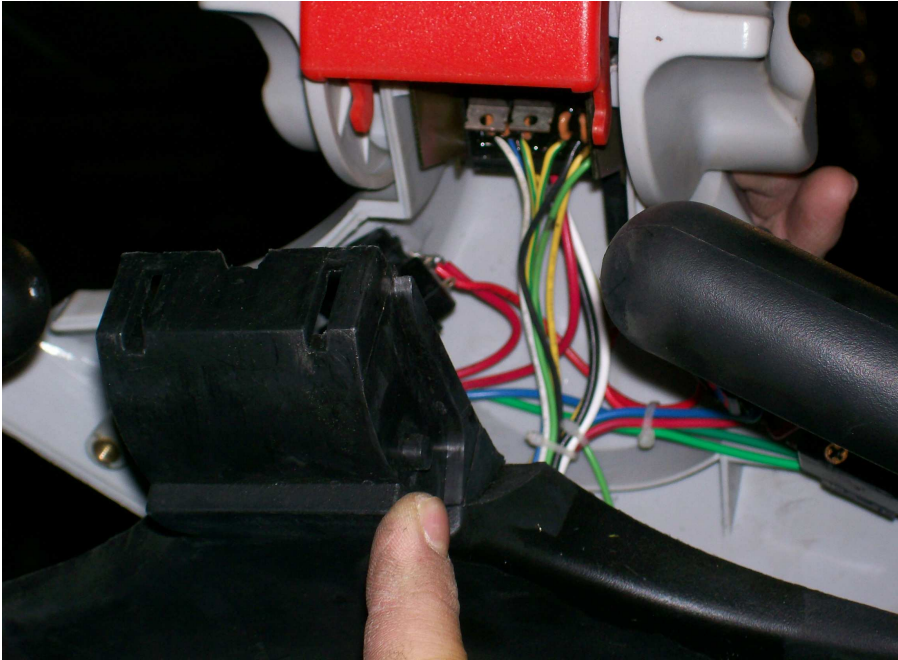

Fig.27

The red tab slides over the top of this black nub on each side when installing the tiller throttle assembly back on the handle.
Fig 28

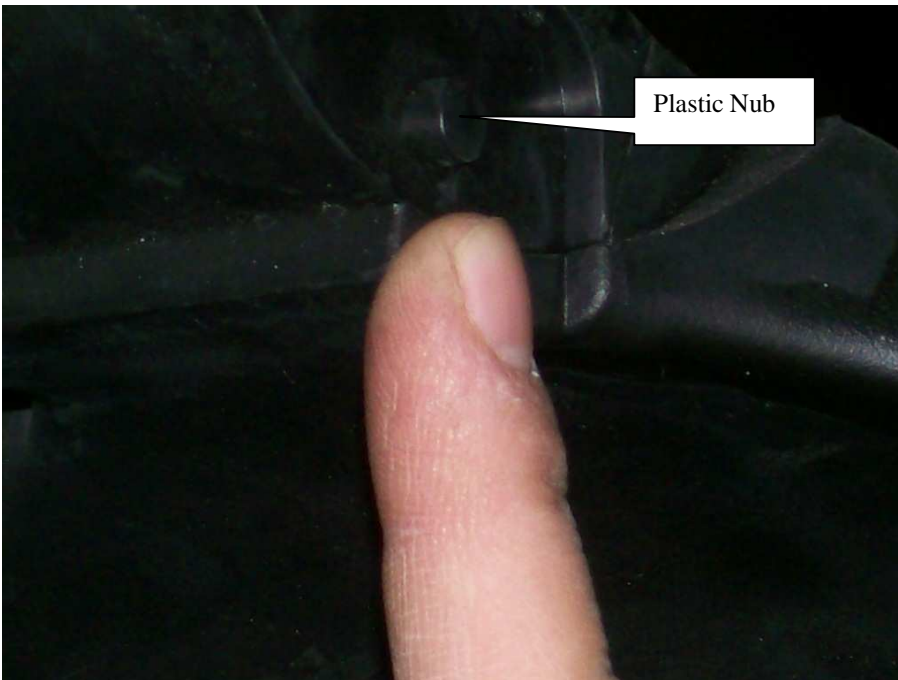
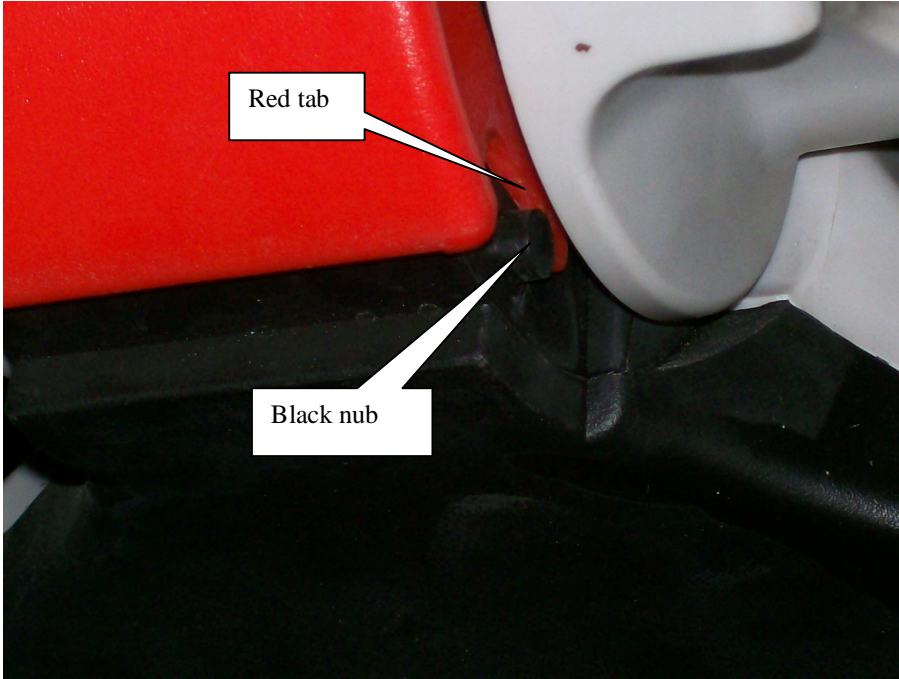

Fig.28

This shows sliding the red tabs over the black nub. This is basically the reverse of Fig8.

Fig28



This is the top front where the two connectors are. Make sure they are on each side of the stand off so the wires do not get pinched. Fig29

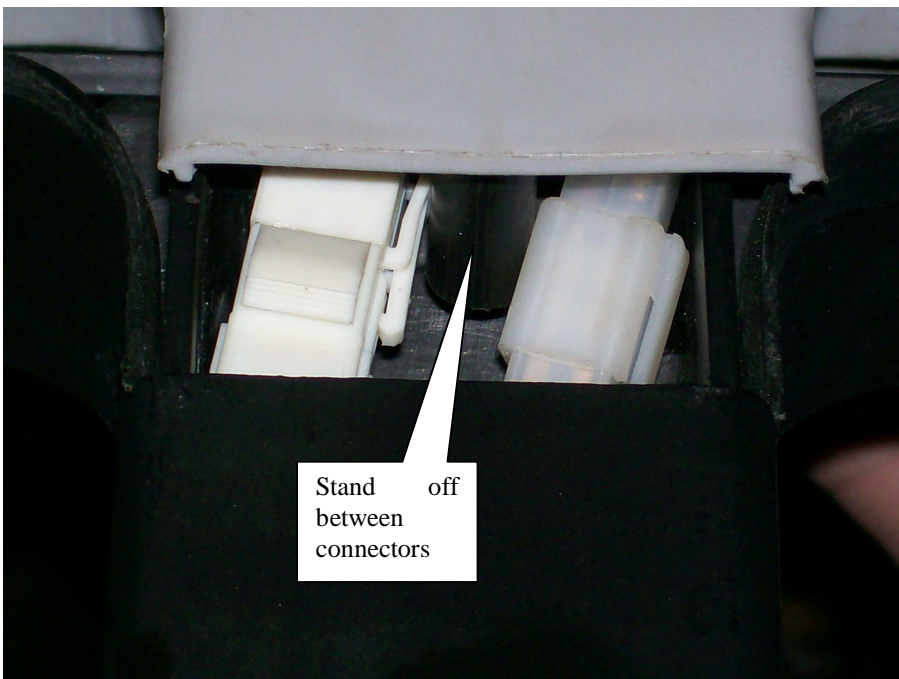
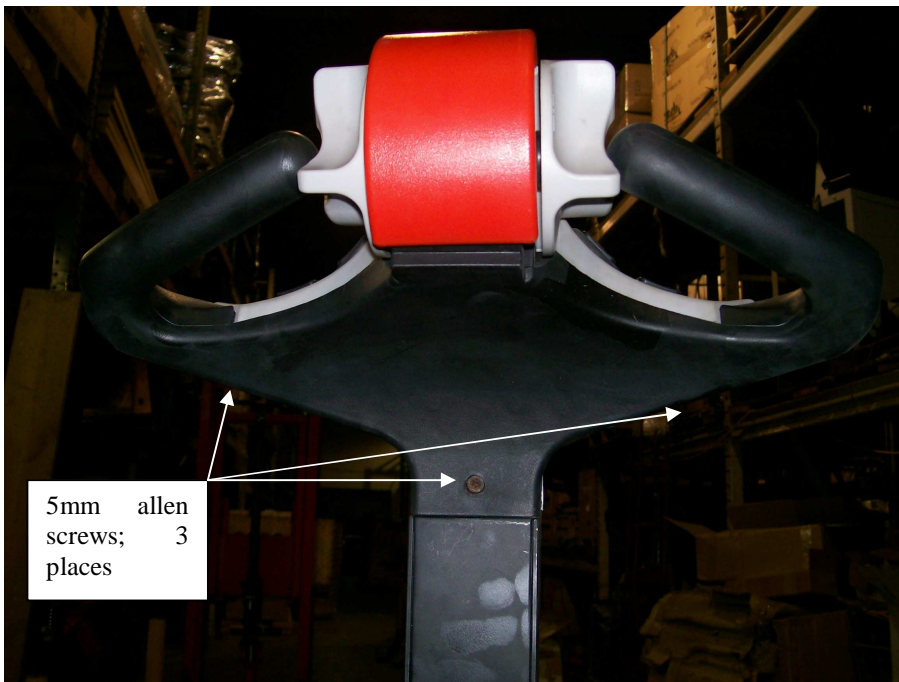

Fig.29

Gently push the tiller throttle assembly in place. Again, it's just reversing steps 5 through 9 to get the tiller throttle assembly back on the handle. Re-install the 3 allen screws, verify no switches are sticking, and that the thumb wheel moves freely. Turn the unit on and verify operation. This completes the assembly.



Maintenance and repair

(A) BEFORE EACH USE INSPECT FOR THE FOLLOWING:

- 1) Frayed wires
- 2) Oil leaks
- 3) Pinched or chafed hoses
- 4) Damage or structural deformation to the structural members, the cylinder brackets, etc.
- 5) Unusual noise or binding, or evidence thereof.
- 6) Proper functioning of all limit switches, including those on the perimeter pinch point guard (if applicable)
- 7) Horn works
- 8) Load chain, check for mechanical damage, check for play (slack chain)
- 9) Battery, keep the surface of battery clean and dry. Make sure battery is secured against slipping

(B) INSPECT MONTHLY FOR:

- 1) The oil level. Oil should be 1-1/2" to 2" below the reservoir's fill hole with the lift in the fully raised position
- 2) Worn or damaged hydraulic hoses and electrical wires
- 3) Pivot point wear
- 4) Roller's looseness and wear
- 5) Integrity of retaining rings on all the rollers and at all pivot points
- 6) Looseness, wear, or damage to the front rollers & drive wheel, bearings, mounting hardware, or surface material
- 7) Proper functioning of any hand-or foot-operated mechanisms
- 8) Proper water level in the battery
- 9) Unusual noises or movement during operation
- 10) All the information, safety, and wearing labels being in place and in good condition
- 11) The need to clean off dirt and debris

(C) YEARLY INSPECTIONS

- 1) The oil should be changed if the oil darkens, becomes gritty, or turns a milky color (indicating the presence of water). Replace with anti-wear hydraulic oil with a viscosity grade of 150sus at 100°F, (ISO 32 at 40°C). Ex:AW 32 or HO 150 hydraulic oil, or a non-synthetic transmission fluid. You may use a synthetic transmission fluid if you flush the system with the synthetic fluid before filling the reservoir.
- 2) Check chain and chain connections for any mechanical damage
- 3) Clean upright channels and mast rollers, & grease slightly.
- 4) Check magnetic brake travel, & if necessary change brake rotor
- 5) Check carbon brushes for any wear in the lift motor, & if necessary change carbon brushes.

Maintenance and repair

Maintenance and care of the load chains

In normal use the load chains should be re-lubricated every 250 operating hours; in the event of heavy soiling, moisture and very high prolonged loading, re-lubrication should be effected after 100 operating hours. If subject to corrosive media the chain should be cleaned and lubricated immediately.

Chain lubrication, chain conservation

Flyer chains are correctly lubricated and are in a perfect state if:

The chain is free of exterior soiling.

When touching the chain, your finger is wetted with oil. This assures that the lubrication of the chain links is sufficient.

Type of lubricant

A low-viscosity mineral – machine – or engine oil or synthetic oil should be used. The viscosity of the lubricating oil is to selected so that it remains low viscose at all ambient temperatures encountered.

Under normal temperature conditions, lubricating oils with a viscosity of SAE 20 to SAE 40 would be appropriate.

Lubricating methods

The lubricant can be applied by means of brush, paint brush or also using compressed air spray devices. When using spray cans, please make sure the following basic requirement is fulfilled:

- After the thinner has vaporized, a viscosity conforming to the above-mentioned recommendation (type of lubricant) must be met.

Cleaning the chain

If operation leads the chain to suffer so heavily from soiling that the penetration of the lubricating oil cannot be guaranteed, the chain must be cleaned.

This is only to be effected with paraffin derivatives such as diesel fuel, petroleum, cleaner's naphtha etc.

Do not clean with steam injectors, cold cleaners or even corrosive and acidic substances. They can directly lead to chain damage.

If the chains have to be cleaned with steam injectors, please contact our customer service.

Maintenance and repair

◆ Chain inspections

Chains used in stackers should be inspected at least once a year or every three months if exposed to severe contamination or high continuous loading stress.

We recommend that attention be paid to the following points:

1. Unusual noise
2. Surface rust
3. Linkage rust
4. Stiff links
5. Distorted pins
6. Loose link pins
7. Damage
8. Broken link plates
9. Broken pins
10. Contamination
11. Stretching

Even with the optimum amount of lubrication, it is impossible to prevent a chain from stretching.

Wear extends only to that part of the chain which is led over the chain sprocket/guide sprocket. Thus, when checking for wear, only check the area need be inspected.

According to the regulations currently in force, a chain is deemed to be worn if it has stretched by 3%.

If safety issues are particularly critical or a potential hazard is dependent on a single chain, we consider it necessary to replace it if it is stretched by even 2%.

Measuring procedure

To measure elongation through wear, that part of the chain which runs over the chain sprocket/guide sprocket must be positioned in the stretched area. With the aid of a measuring rod, measure a section approximately 1 meter in length.

The number of divisions in the measured area, multiplied by the chain divisions, gives the nominal measurement. The length extending beyond this measurement represents the wear, which is limited to a maximum of 3% over the nominal length.

An elongation through wear of 3% is reached if 33 links of the chain in use measure the same length as 34 links of a new chain.

◆ Chain replacement

If two chains are used as a pair on the affected machine, both should always be changed at the same time.

The installation and removal of chains should be carried out with all the care appropriate to any item of safety equipment.

Chains may only be repaired by authorized specialist personnel.

We do not recommend the lengthening of safety-type lifting chains, since the inserted chain link will not have been pre-stretched.

Our product liability will be invalidated if a repaired chain is assembled from sections bearing different silver label numbers.

Maintenance and repair

◆ Temporary lay-up

If, for operating reasons, the stacker is laid up for more than two months, the following instructions are to be carried out:

- * Place the stacker on blocks so that all the wheels are raised from the floor. In this way, they will be prevented from becoming permanently misshapen.
- * Clean the stacker thoroughly.
- * It may be necessary to support the lifting gear in a suitable manner, so as to relieve any stress on the load chains.
- * Check the hydraulic fluid level, replenish if necessary.
- * Grease the stacker thoroughly.
- * Clean all bright and moving parts with a thin film of oil and grease respectively.
- * Store the stacker in a dry, frost-proof, dust-free place.
- * Do not use plastic sheeting to cover the stacker otherwise condensation could form under it.

Additional operations for vehicles with integral electrical systems

- * Disconnect the batteries from the stacker electrical system.
- * Charge the batteries.
- * Clean the top of the battery case and terminals.
- * Grease the terminals lightly with terminal grease.
- * Check the electrolyte level, top up if necessary (not applicable to maintenance-free or gel batteries).
- * Recharge the batteries every 90 days; gel batteries every 6 months.
- * Spray a suitable contact spray on unattached electrical contacts.

Return to service after a lay-up

- * Thoroughly clean and grease the stacker.
- * Remove the film of protective grease.
- * Check the hydraulic fluid tank and hydraulic fluid for condensation, if necessary carry out a fluid change.
- * Inspect hydraulic hose lines for brittleness.
- * Test the functions of the vehicle, particularly the safety equipment.

Serial No. _____

Model: _____

LIMITED WARRANTY

Vestil Manufacturing Corporation (Vestil) warrants each model SE/HP, S-CB, SL-series or S-series Stacker to be free of defects in material and workmanship during the warranty period. Our warranty obligation is to provide a replacement for a defective original part (a part used to make the product as shipped to the warrantee) after we receive a proper request for warranty service. "Proper request" means that we must receive: 1) a photocopy of your Customer Invoice that displays the shipping date; AND 2) a written request for warranty service that includes your name and phone number. Send requests by any of the following methods:

Mail

Vestil Manufacturing Corporation
2999 North Wayne Street, PO Box 507
Angola, IN 46703

Fax

(260) 665-1339

Phone

(260) 665-7586

Email

sales@vestil.com

In the written request, list the parts you believe are defective and include the address where replacements should be delivered. After Vestil receives your request, an authorized representative will contact you to determine whether your claim is covered by the warranty (also see "If a defective part is covered..." below). Before providing warranty service, Vestil may require you to send the entire product or the defective part or parts to its facility in Angola, Indiana.

Who may request service?

Only the warrantee may request service. *You are a warrantee if* you purchased the product from Vestil or from an authorized distributor AND Vestil has been fully paid.

What is covered under the warranty?

The warranty covers the following *original* drive and lift components: drive motors and lift motors, hydraulic pumps, electronic controllers, switches and cylinders. It also covers *original* parts that wear under normal usage conditions ("wearing parts"): bearings, hoses, wheels, seals, brushes, batteries, and the battery charger. The warranty period for drive and lift components is 1 year. For wearing parts, the warranty period is 90 days. Both warranty periods begin on the date when Vestil ships the product to the warrantee. If you purchased the product from an authorized distributor, the periods begin when the distributor ships the product, which extends the warranty by up to an additional 30 days.

If a defective part is covered by the warranty, what will Vestil do to correct the problem?

Vestil will provide an appropriate replacement for any *covered* part. An authorized representative of Vestil will contact you to discuss your claim.

What is not covered by the warranty?

1. Labor costs or Freight;
2. Any of the following automatically void the warranty:
 - Product misuse;
 - Negligent operation or repair;
 - Corrosion or use in corrosive conditions;
 - Inadequate or improper maintenance;
 - Failure to exercise good judgment;
 - Damage sustained during shipping;
 - Accidents involving the product;
 - Unauthorized modifications: Do NOT modify the product IN ANY WAY without first receiving written authorization from Vestil. Modifications may render the pallet truck or stacker unsafe to use or might cause excessive and/or abnormal wear.

Do any other warranties apply to the product?

Vestil Manufacturing Corp. makes no other express warranties. Any warranty implied-by-law is limited in duration to the warranty period.



Part list

Electric wiring

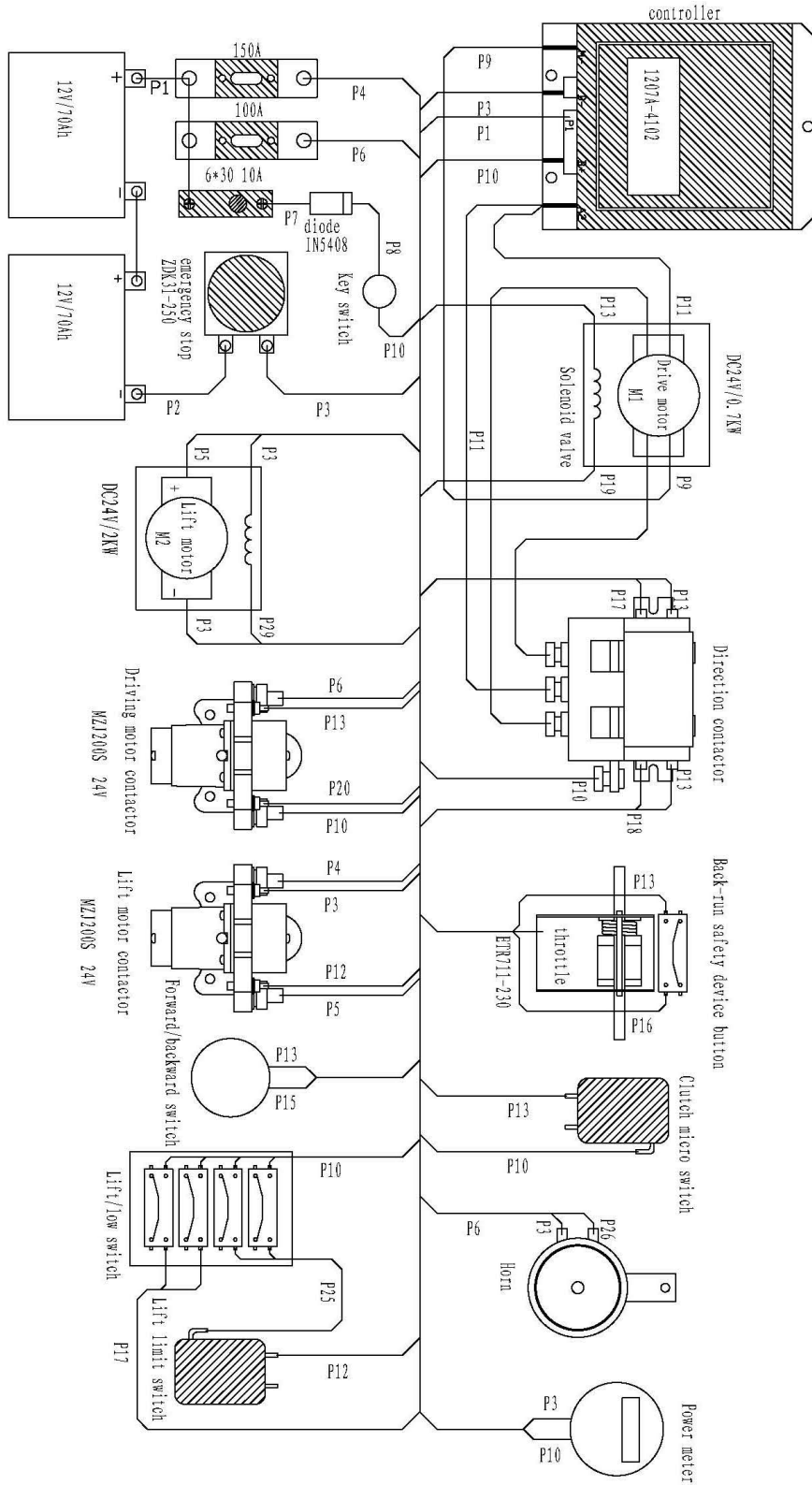

Part list

Electric circuit

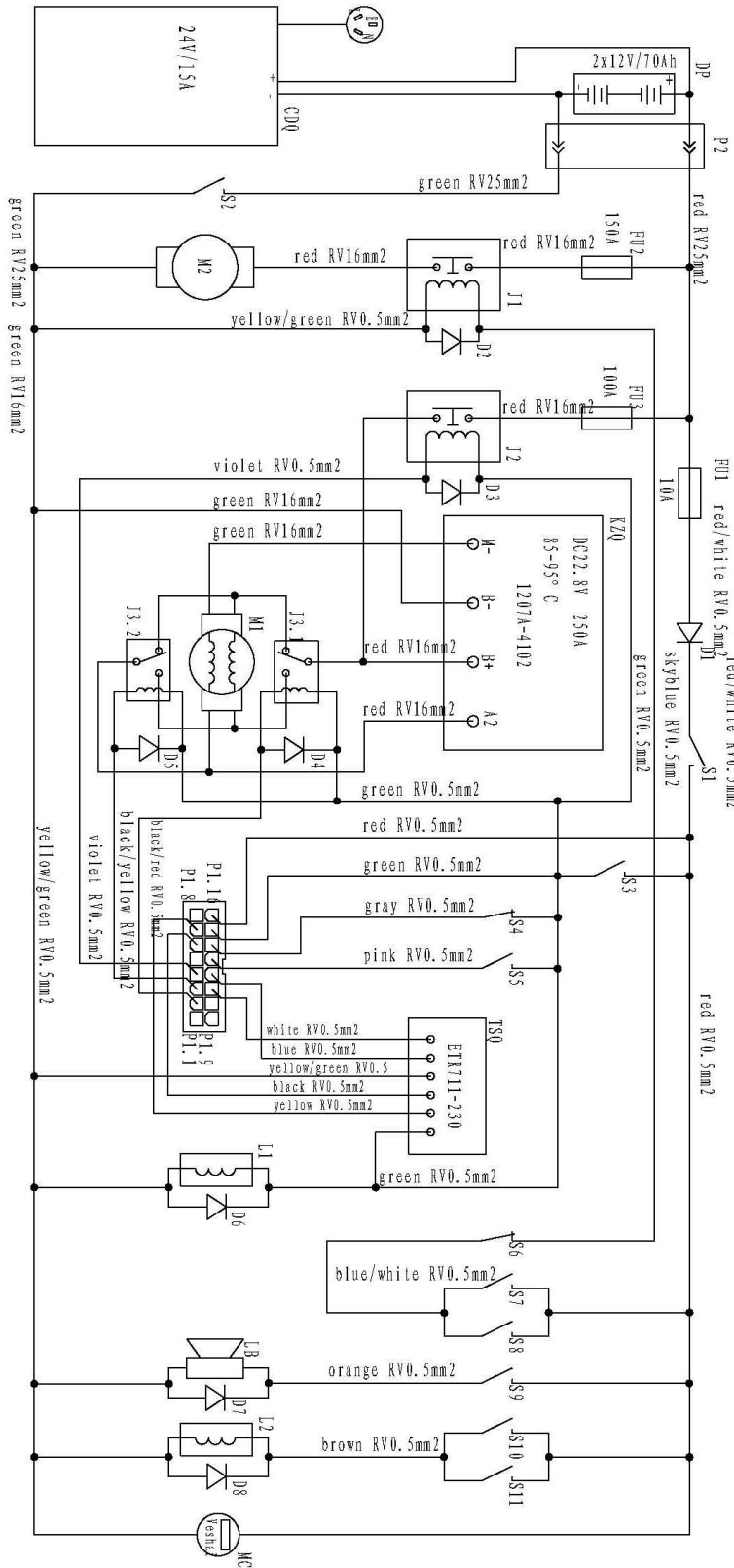

Part list

S-62 Electric component list

NO	Name	Code	Specification	Qty
1	Battery	DP	12V/70Ah	2PCS
2	Controller	KZQ	1207A-4102	1PC
3	Drive motor	M1	DC24V/0.7KW	1PC
4	Lift motor	M2	DC24V/2.0KW	1PC
5	Lift motor contactor	J1	MZJ200S 24V	1PC
6	Drive motor contactor	J2	MZJ200S 24V	1PC
7	Direction contactor	J3.1	DC88-1 24V	1PC
8	Direction contactor	J3.2	DC88-1 24V	1PC
9	Control circuit fuse	FU1	Ø6X30 10A	1PC
10	Hydraulic circuit fuse	FU2	150A	1PC
11	Drive circuit fuse	FU3	100A	1PC
12	Electromagnetic clutch	L1	DC24V/28W	1PC
13	Solenoid valve	L2	DC24V/16W	1PC
14	Horn	LB	DL1216	1PC
15	Power meter	MC	DC24V	1PC
16	Throttle	TSQ	ETR711-230	1PC
17	Diode	D1	IN5408	1PC
18	Diode	D2-D8	IN4007	7PCS
19	Battery charger	CDQ	24V/15A	1PC
20	Key switch	S1	S001	1PC
21	Emergency stop	S2	ZDK31-250	1PC
22	Clutch micro switch	S3	TM1703	1PC
23	Forward/backward switch	S4	TM1703	1PC
24	Back-run safety device button	S5	KW2-OZ	1PC
25	Lift limit switch	S6	KW2-OZ	1PC
26	Lift switch	S7,8	KW2-OZ	2PCS
27	Horn switch	S9	KW2-OZ	1PC
28	Low switch	S10,11	KW2-OZ	2PCS
29	Power plug		DC110V/200A	2PCS
30	Electric wire		RV16mm ²	
31	Electric wire		RV0.5mm ²	

HYDRAULIC CIRCUIT DIAGRAM

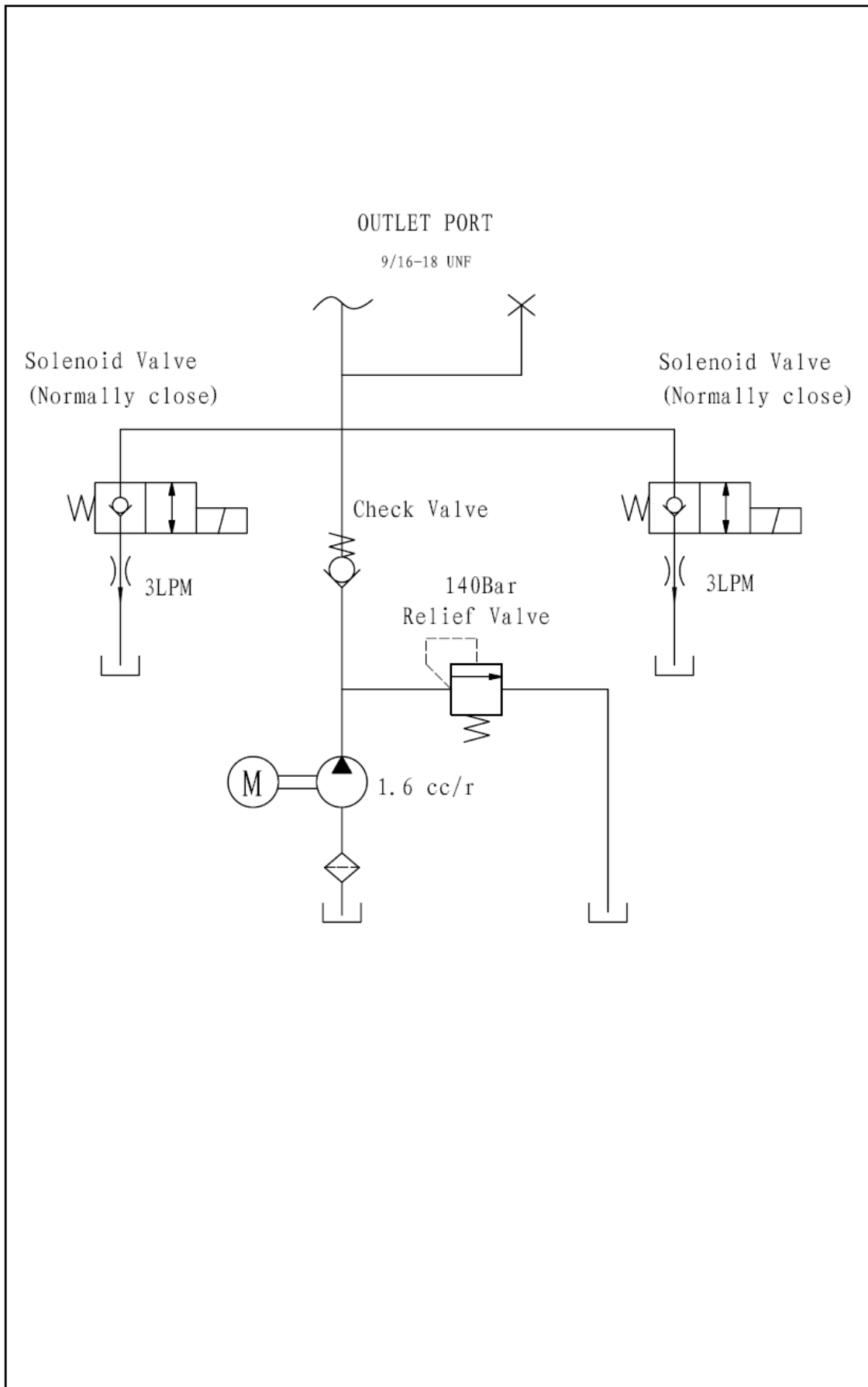

Part list

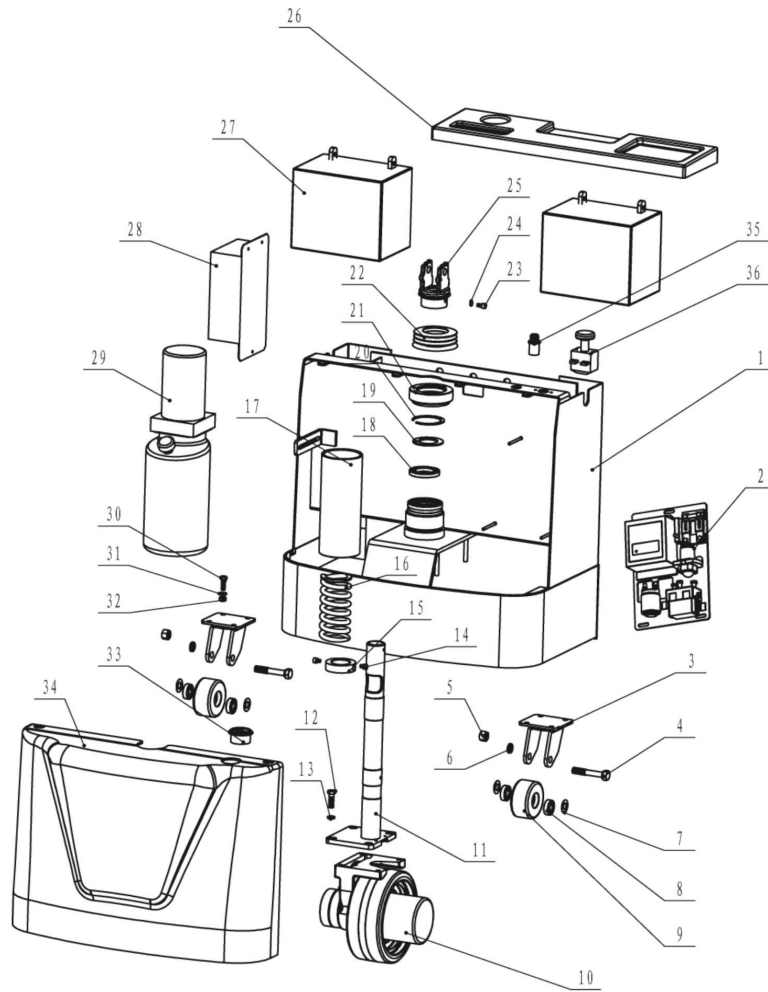

No.	Part Number	Part Name	Qty	No.	Part Number	Part Name	Qty
1	1000	Main Frame	1	19	3309	Plastic Cover	1
2	3300	Electric Control Panel	1	20	3310	Snap Ring \varnothing 80	1
3	1100	Balance Castor	2	21	3311	Steel Cover	1
4	1101	Bolt M16X90	2	22	3312	Rubber Seal	1
5	1102	Nut M16	2	23	3313	Hex Socket Bolt M8x10	2
6	1103	Spring Washer \varnothing 16	2	24	3314	Spring Washer \varnothing 8	2
7	1104	Washer	4	25	3315	Handle Base	1
8	1105	Bearing 6203	4	26	1001	Top Fiber Glass Cover	1
9	1106	Wheel \varnothing 100x50	2	27	1002	Battery	2
10	3200	Driving Wheel	1	28	1003	Charger	1
11	3301	Directional Axle	1	29	3100	Power Pack	1
12	3302	Bolt M12x25	4	30	1107	Bolt M10x30	8
13	3303	Spring Washer \varnothing 12	4	31	1108	Spring Washer \varnothing 10	8
14	3304	Hex Socket Bolt M6x20	2	32	1109	Hex Nut M10	8
15	3305	Steel Hoop	1	33	1004	Battery meter	1
16	3306	Spring	1	34	1105	Fiber Glass Cover	1
17	3307	Steel Pipe	1	35	1106	Switch	1
18	3308	Bearing 16010	1	36	1107	Emergency Brake	1

Part list

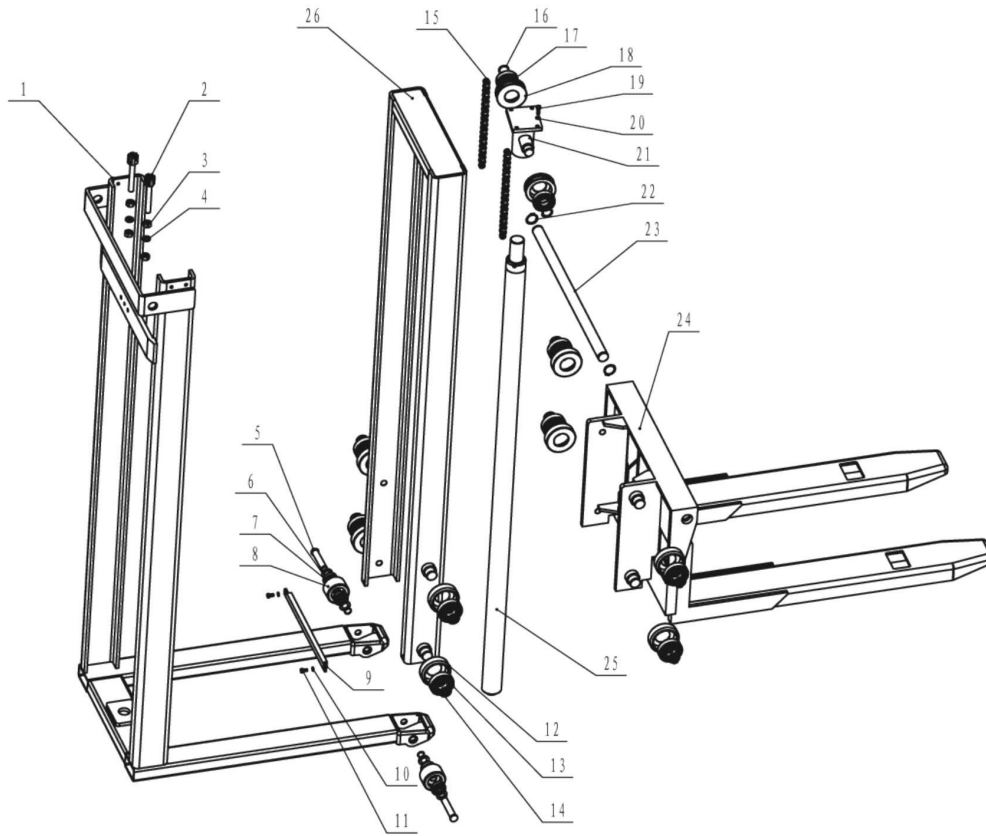

No.	Part Number	Part Name	Qty	No.	Part Number	Part Name	Qty
1	2000	Outer Mast	1	14	2106	Snap Ring \varnothing 35	8
2	2001	Bolt M16	2	15	2107	Chain LH1223	2
3	2002	Hex Nut M16	4	16	2108	Snap Ring \varnothing 30	2
4	2003	Spring Washer \varnothing 16	2	17	2109	Bearing 6306	2
5	2004	Front Wheel Axle	2	18	2110	Chain Roller	2
6	2005	Washer	4	19	2111	Bolt M8x20	4
7	2006	Bearing 6204	4	20	2112	Spring Washer \varnothing 8	4
8	2007	Wheel \varnothing 75x50	2	21	2113	Chain Roller Base	1
9	2101	Shaft	1	22	2201	Snap Ring \varnothing 35	2
10	2102	Spring Washer \varnothing 8	2	23	2202	Fork Shaft	1
11	2103	Bolt M8x20	2	24	2200	Fork Bracket	1
12	2104	Roller Bushing	8	25	2300	Cylinder	1
13	2105	Bearing 6307	8	26	2100	Inner Mast	1

Part list

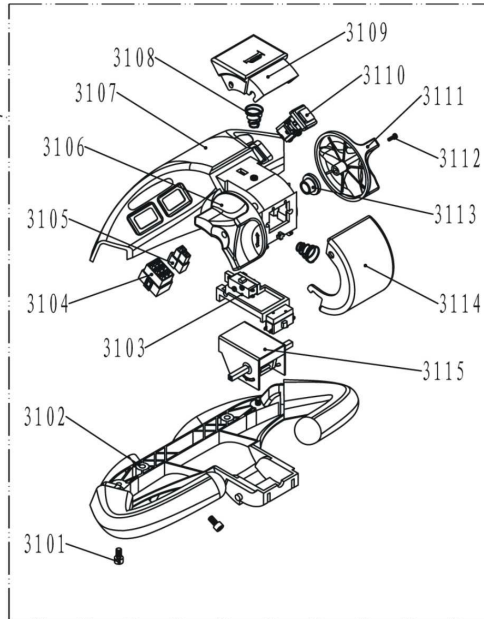
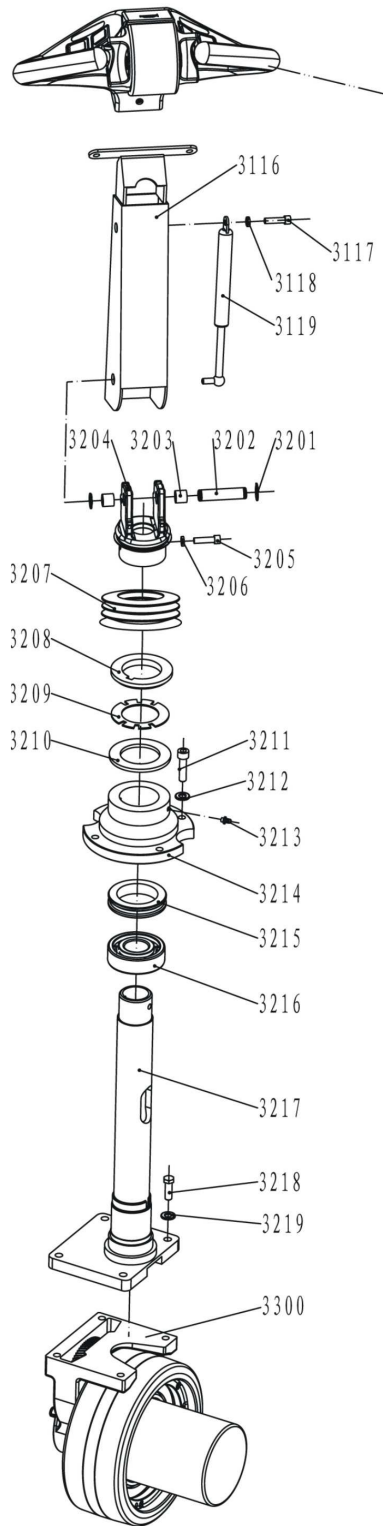

No.	Description	Qty.
3101	Screw	3
3102	Handle main frame	1
3103	Front button	1
3104	outlet outlet(big)	1
3105	outlet outlet(small)	1
3106	Speed control knob	1
3107	Main cover	1
3108	Spring	2
3109	Horn button	1
3110	Button group	1
3111	Right handle cover	1
3112	Bolt M3x10	2
3113	Plastic washer	2
3114	Emergency stop buttor	1
3115	Electric throttle	1
3116	Handle bar	1
3117	Nut M8x10	1
3118	Washer	1
3119	Pneumatic spring	1
3201	Snap ring 20	1
3202	Set bearing	1
3203	Brush	2
3204	Handle board	1
3205	Screw	1
3206	Washer	1
3207	Cover coupler, rubber boot	1
3208	Bearing	1
3209	Bearing	1
3210	Washer	1
3211	Nut	4
3212	Washer	4
3213	Oil cup M8x1	1
3214	Wheel set	1
3215	Bearing8112	1
3216	Bearing 80113	1
3217	Steering pole	1
3218	Bolt	4
3219	Washer	4
3300	Drive wheel system	1