

PALLET MASTER/SERVER - PMPS-50-AIR

APPROX WEIGHT: 983.56 lbs.
 DOES NOT INCLUDE WEIGHT OF POWER OR PACKAGING!!!

*** ANY ADDITIONS, DELETIONS, OR OMISSIONS MUST BE CORRECTED ON THIS DRAWING AS THIS DRAWING WILL BE CONSIDERED ALL INCLUSIVE ***

ALL GRAPHICS PROVIDED ARE FOR REFERENCE ONLY. IF CERTAIN DIMENSIONS ARE CRITICAL PLEASE VERIFY THOSE DIMENSIONS WITH YOUR SALESPERSON

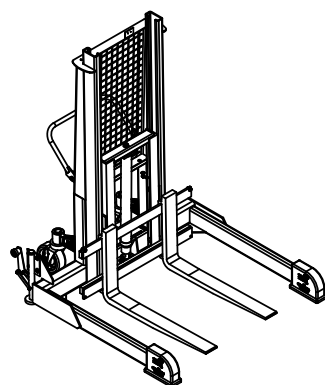
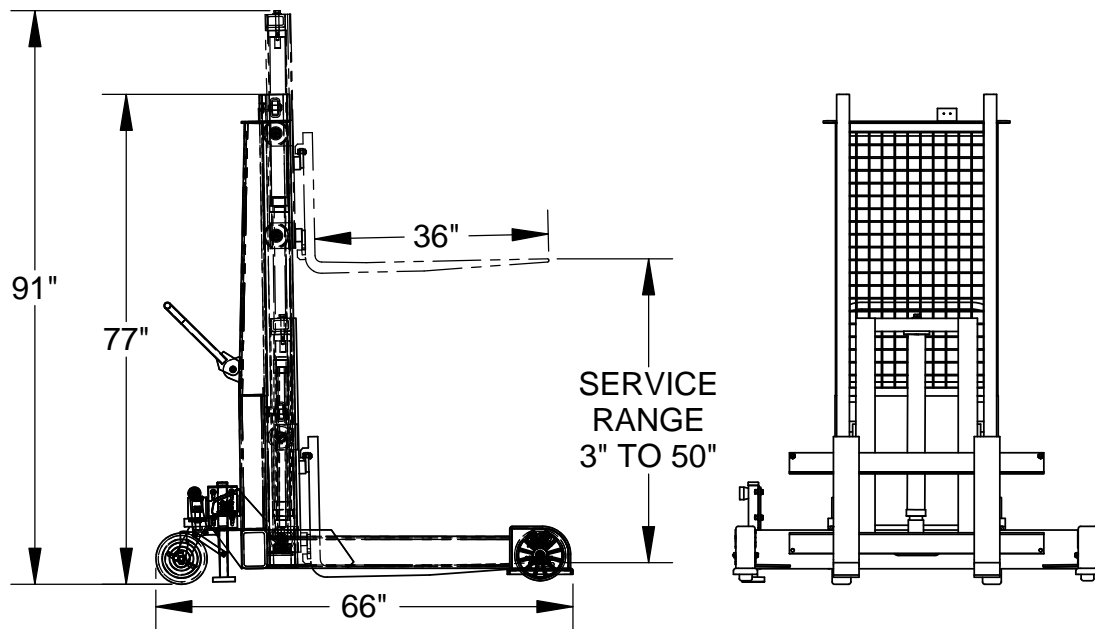
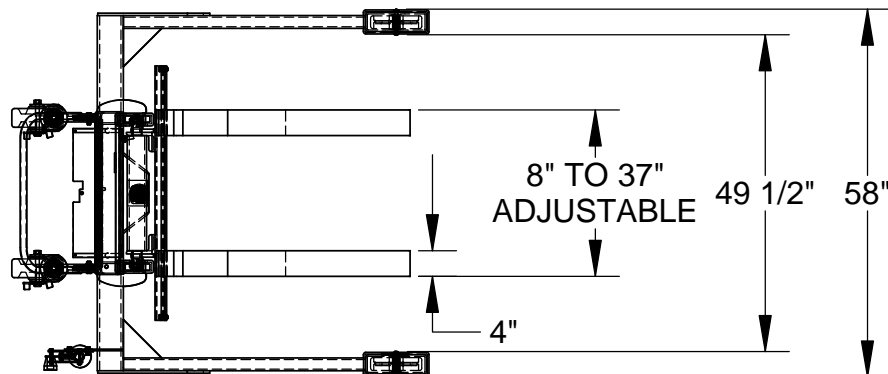

STANDARD FEATURES

- MODEL NUMBER IS PMPS-50-AIR
- OVERALL WIDTH IS 58"
- STRADDLE INNER DIMENSION IS 49 1/2"
- OVERALL LENGTH IS 66"
- OVERALL RAISED HEIGHT IS 91"
- OVERALL LOWERED HEIGHT IS 77"
- FORK RAISED HEIGHT IS 50"
- FORK LOWERED HEIGHT IS 3"
- MAXIMUM FORK HEIGHT BEFORE CARRIAGE EXCEEDS HEIGHT OF MAST IS 36 1/2"
- FORK CAPACITY (EVENLY DISTRIBUTED) IS 4000 LBS.
- FORKS ARE 1 1/2" THICK x 4" WIDE x 36" LONG
- MAXIMUM FORK SPREAD IS 37" O.D.
- FLOOR LOCK
- ALL STEEL CONSTRUCTION (ASTM A-36 MINIMUM)
- RECIPROCATING AIR POWERED HYDRAULIC 15 CFM @ 100 PSI (1/4 GPM)
- FOOT TREADLE CONTROL

FOR INTERNAL USE ONLY PROJECT SIGN OFF	
SALES	
ENG.	
FAB.	
POWER	

DIMENSION TOLERANCE ± 1/4"

SPECIAL FEATURES

NONE

APPROVAL

I, THE UNDERSIGNED, AGREE THAT THE PRODUCT AS REPRESENTED SATISFIES DESIGN AND DIMENSION REQUIREMENTS. I ALSO ACKNOWLEDGE MY DUTY TO CONFIRM PRODUCT AND INSTALLATION COMPLIANCE WITH ALL APPLICABLE FEDERAL, STATE AND LOCAL REGULATIONS AND STANDARDS.

ANY MODIFIED UNITS ARE NON-RETURNABLE

[] As drawn [] As marked

Signed: _____ Date: _____

Printed Name: _____

LEAD TIME WILL START UPON RECEIPT OF SIGNED APPROVAL DRAWING

DISTRIBUTOR'S NAME:		P.O.#
VESTIL MANUFACTURING		X
DRAWN BY: K.HOOS		W.O.#
DATE: 5/31/2016		X
REFERENCE: X	SCALE: 1:30	SALES: X
QUOTED LEAD TIME: X	QUOTE #	FILE NAME:
	X	15-007-020-002