

PEL-33

Capacity: 330 lbs.

Raised Height: 61-13/64"

Lowered Height: 5-1/8" (Platform), 4-17/32" (Double Spindle), 4-21/64" (Single Spindle)

Lifting Speed: 3.26 in/s (without load), 2.75 in/s (with full load)

Lowering Speed: 3.34 in/s (without load), 3.97 in/s (with full load)

Platform Size (width x length): 20-1/2" x 18"

Battery: 7Ah/12V

Front Roller: 3 x 1-1/4"

Rear Roller: 4 x 1-1/4"

Front Leg (height): 4 3/8"

I.D. Of Front Legs: 16"

O.D. Of Front Legs: 19 1/2"

Weight: 128 lbs. (Platform), 124 lbs. (Double Spindle), 118 lbs. (Single Spindle)

Overall Dimensions (width x length x height): 20-1/2" x 32-43/64" x 73-5/8"

Max. Turning Radius: 36"

PEL - 33

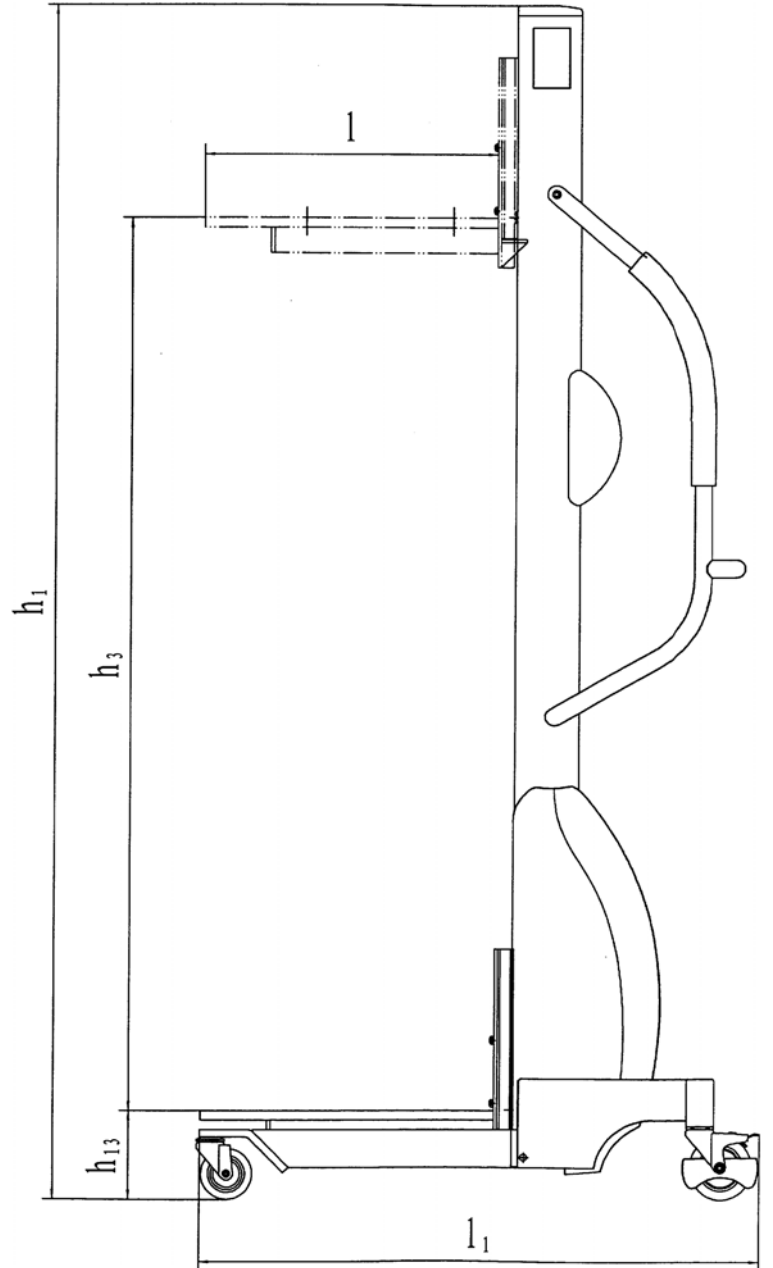
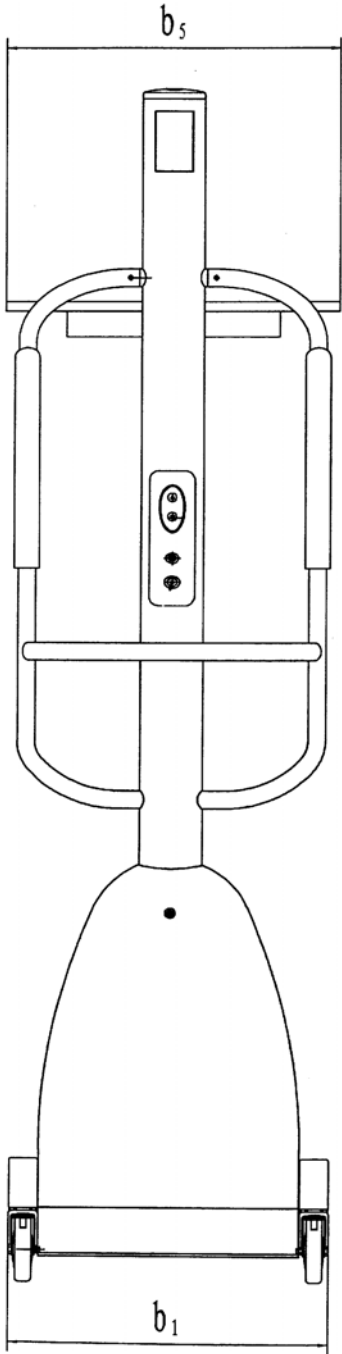

1. TECHNICAL FEATURES

Identification	1.2	Model Number	PEL-33		
	1.4	Type of operation :hand , pedestrian, standing, seated, order-picker	hand		
	1.5	Load Capacity / rated load Q(lbs)	330		
Weights	2.1	Service weight lbs	128		
Wheels, Chassis	3.1	Wheel Material	polyurethane		
	3.2	Wheel size, front	Ø2.9 × 1 ¼		
	3.3	Wheel size, rear	Ø2.9 × 1 ¼		
	3.5	Wheels, number front/rear(x=driven wheels)	4		
Basic Dimensions	4.2	Lowered mast height h ₁ (in)	73-5/8		
	4.4	Lift height h ₃ (in)	56		
	4.15	Lowered height h ₁₃ (in)	5-1/8		
	4.19	Overall length l ₁ (in)	34-5/8		
	4.21	Overall width b ₁ (in)	20-1/2		
	4.22	Fork dimensions l(in)	18-1/8		
	4.25	Width over forks b ₅ (in)	20-1/2	MES-150A 15-3/4(φ1-9/16×2)	MES-150B Φ2-3/8
Performance Data	5.2	Lift speed, loaded/unloaded in/s	2.75/3.26		
	5.3	Lowering speed, loaded/unloaded in/s	3.97/3.34		

2. ADVISES

- 2.1 Read this instruction carefully before using the stacker. If necessary, please call our technical people for assistance.
- 2.2 Move the stacker always keeping the forks at the lowest position while no loading on the forks. Pay attention not to hurt anybody around your working area.
- 2.3 People are forbidden to stand on the forks of the stacker. Do not leave the stacker on the working place after used. The load capacity of the stacker depends on the lifting height and the position of the load center; please refer to the relative technical features in this instruction.
- 2.4 The adhesive label on the stacker must be always legible. Do not use the stacker for purpose except lifting or lowering load.
- 2.5 Do not make casual repair. If repaired by unprofessional people, the safety modulus of the machine could be altered. In case damage happens, repair it in the local place according to the instruction or contact to us.
- 2.6 Carry out all the work and maintenance according to the norms after using it.

3. WORKING NORMS FOR THE OPERATOR

Do not worry about how to operating this stacker, the characteristic of this stacker is facility and easy to operate.

3.1 The two function of the brakes

The rear wheels are equipped with brakes which with two functions, it can control the moving of forward and backward effectively. Step the pedal of the brake backward, the stacker will be braked. Step the pedal of the brake forward, the stacker will travel normally. The stacker should be braked under the condition as following: A, stop at the slope; B, during charging; C, when loading; D, leave unused.

3.2 The forward/backward/swivel of the stacker

Open the brake of the rear wheels, leave the two wheels at the state which can swivel freely. Take hold of the armrest, push the stacker ahead, the stacker can move ahead. In the same way, pull the stacker backward, the stacker will fall back. We use universal wheels on this truck, so it's very easy to swivel and swivel into any direction. It's only need a small space because it can be freely swiveled at the original position. If one of the brake is locked, the stacker will be swiveled on an even keel according to the centre of a circle.

3.3 Lifting and lowering of the forks

Press the button of power to "ON", then press the "◀" or "▶" to control the lifting and lowering of the stacker. (Attention: Before lifting or lowering the forks with load on the forks, please lock the rear wheels of the stacker to avoid moving of the stacker during lowering and lowering.)

3.4 Load of the stacker

According to the deferent goods, this stacker can use the three kinds of shelves as double forks, single fork, and platform. The ways of how to use these shelves are as follows:

A. Double forks (be fitted for lifting the common load)

- (1) Drive close to the load.
- (2) Lift the forks below the load.
- (3) Drive forward, bringing the forks under the load.
- (4) Lift the load to get the load.
- (5) Back the stacker with the load to make the descent if possible.
- (6) Lower the load slowly.

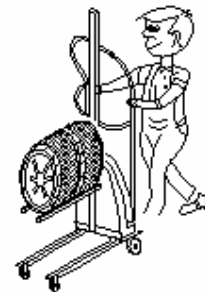

B. Single fork (be fitted for lifting the cylindrical load)

- (1) Drive close to the load.
- (2) Drive the fork to the centre of the circle of the load.

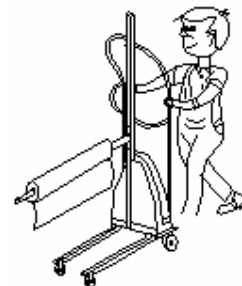

- (3) Drive forward, extend the fork inside the cylinder.
- (4) Lift the load to get the load.
- (5) Back the stacker with the load to make the descent if possible.
- (6) Lower the load slowly.

C. Platform (be fitted for the lifting the load with small volume)

- (1) Drive close to the load.
- (2) Lift the platform to a proper position (be convenient for people to stack the goods)
- (3) Transfer the goods to the platform artificially.
- (4) Lower the platform.

Attention: If possible, the platform with load can be lifted as the double forks.

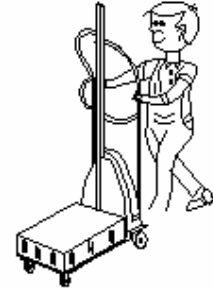

3.5 The steps of unloading the goods

A. Double forks/ single forks

- (1) Get close to the position.
- (2) Lift the load up to the desired height position.
- (3) Advance slowly to bring the load to the proper position.
- (4) Lower the load to make the bottom of the forks on the shelf.
- (5) After unloaded, back the forks slowly.

B. Platform

- (1) Drive the stacker with load to the destination, and lock the rear wheels.
- (2) Lift the platform to a proper height for people to unload it.
- (3) Unloading.

4. RECHARGE OF BATTERY

The batteries of the stacker must be recharged with a constant continuity, and the recharging should be very timely.

When recharging, switch off the power. Connect the charger to the power supply, and insert the plug of the charger into the recharging faucet of the stacker, press the switch of charger, recharging will begin. When recharging is over, the charger will stop automatically.

5. DAILY MAINTENANCE

The daily maintenance is a responsibility of the operator of the stacker. The main functions that must be checked are as follows:

1	Check the retarder of the motor.
2	Check the forks.
3	Check the swivel wheel.
4	Check the transmission belt.
5	Check the charger.

6. PROGRAMMED MAINTENANCE

In the following we show a table in which there are some tips about the programmed maintenance done by the authorized operators.

Before starting the maintenance you have to:

1. Put the stacker on an even and solid surface.
2. Brake both the rear wheels.

1	Check electrical systems, cleaning with air or with a brush and special detergent
2	Check the connections of the conductors.
3	Check and clean the driving-wheel group.
4	Check the wear of rollers and wheels.
5	Check movements and wears between masts and rollers with bearings.
6	Check and tighten all the screws and nuts.
7	Complete greasing of the stacker, bearings and sliding masts.

SPARE PARTS OF THE LIFTING PARTS (Figure 1)

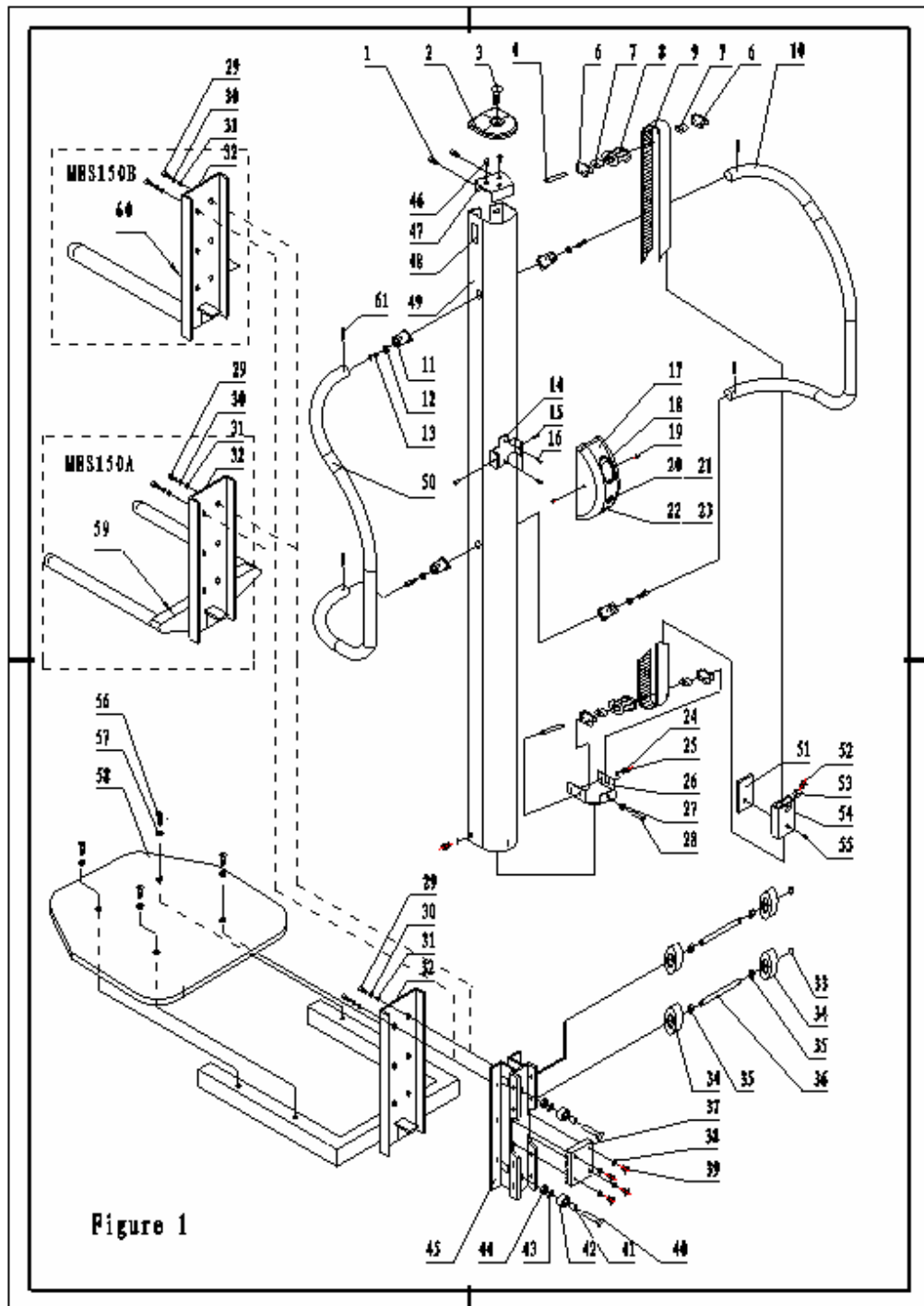

Figure 1

NO	Item No.	DESCRIPTION	QTY	NO	Item No.	DESCRIPTION	QTY
1	10101	Inner screw M6*10	2	32	10132	Frame	1
2	10102	Cover	1	33	10133	A retaining ring 10	4
3	10103	H screw M6*10	1	34	10134	Assembly of roller	8
4	10104	Shaft of transmission	1	35	10135	Plastic washer	1
5	10105			36	10136	Shaft	4
6	10106	Elastic washer (2 each)	4	37	10137	Board	1
7	10107	Bearing 60101(12*28*8)	1	38	10138	Locking nut M5	4
8	10108	Transmission roller	2	39	10139	Screw M5*25	4
9	10109	Transmission belt	1	40	10140	Screw M8*30	2
10	10110	Assembly of right armrest	1	41	10141	Bushing	2
11	10111	Sleeve	4	42	10142	Oriental roller	2
12	10112	Washer 8	4	43	10143	Flat washer 8	2
13	10113	Inner screw M8*16	4	44	10144	Locking nut M8	3
14	10114	Frame of installation	1	45	10145	Frame of transmission	1
15	10115	Screw M4*10	2	46	10146	Round screw M6*50	2
16	10116	Screw M6*10	2	47	10147	Board	1
17	10117	Switch box	1	48	10148	Warning sticker	2
18	10118	Switch of lifting & lowering	1	49	10149	Pipe	1
19	10119	Screw M4*10	2	50	10150	Assembly of left armrest	1
20	10120	Recharging sticker	1	51	10151	Board	1
21	10121	Recharging socket	1	52	10152	Screw M3*10	2
22	10122	Sticker of power	1	53	10153	Assembly of alnico	2
23	10123	Micro switch	1	54	10154	Alnico Fitted frame	1
24	10124	Inner round screw M8*20	2	55	10155	Screw M6*12	1
25	10125	Flat washer 8	2	56	10156	Screw M6*30	4
26	10126	Roller frame	1	57	10157	Locking nut M6	4
27	10127	Locking nut	3	58	10158	Splint	1
28	10128	Inner screw M8*25	1	59	10159	Two-arm welding-fork	1
29	10129	Inner screw M6*16	6	60	10160	One-arm welding-fork	1
30	10130	Flat washer 6	6	61	10161	Elastic pin $\phi 6 \times 28$	4
31	10131	Nut M6	6				

SPARE PARTS OF THE FORKS (Figure 2)

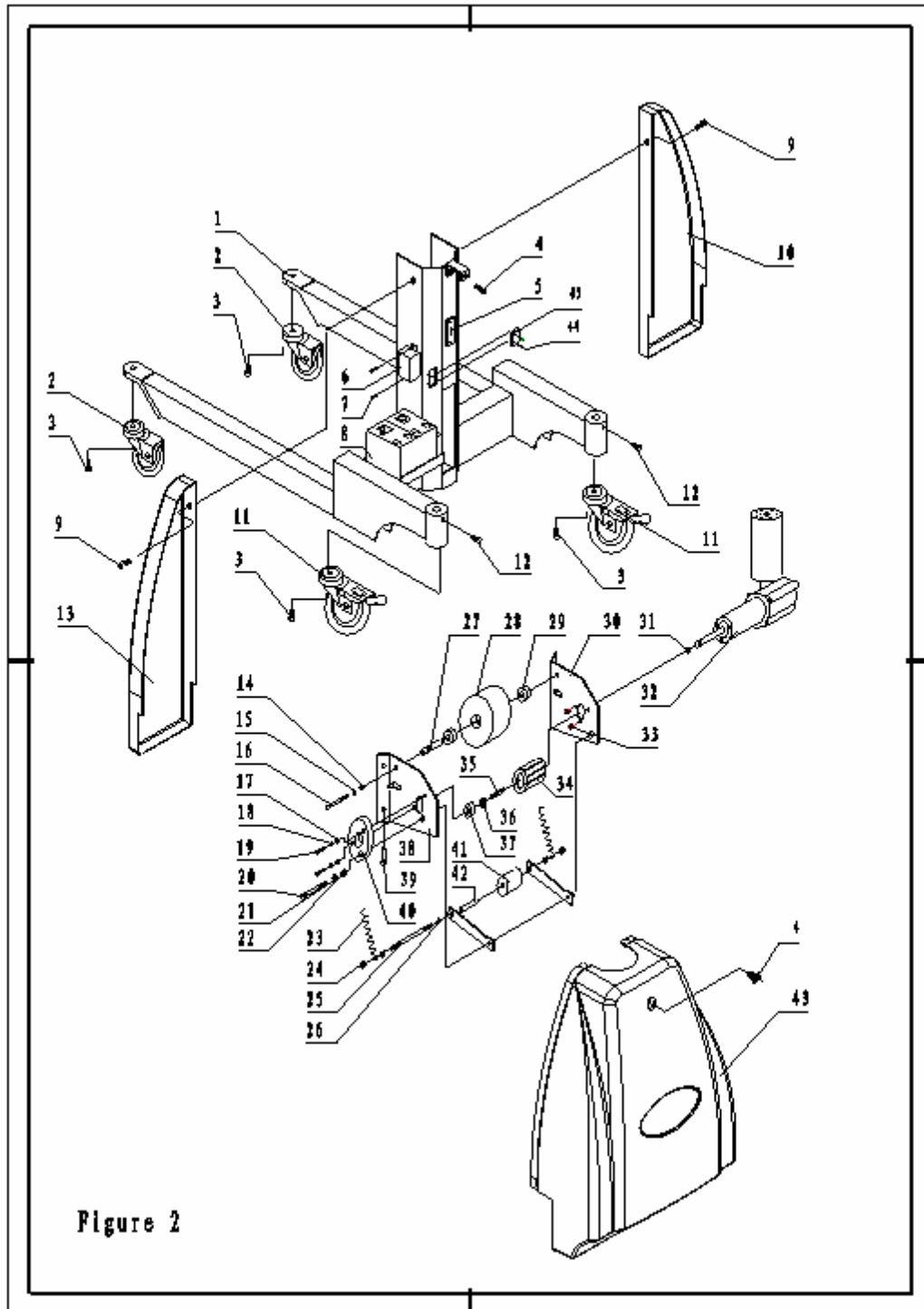
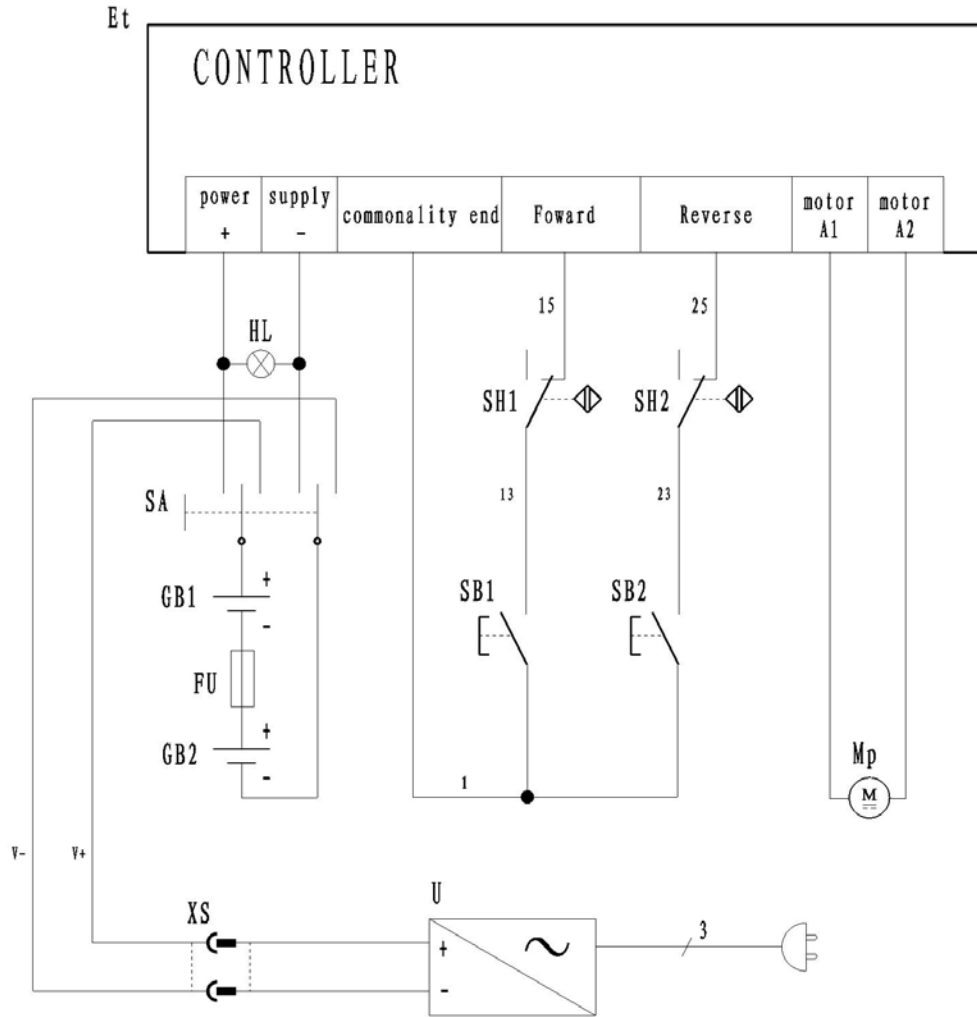

Figure 2

NO	Item No.	DESCRIPTION	QTY	NO	Item No.	DESCRIPTION	QTY
1	10201	Frame	1	24	10224	Locking nut	4
2	10202	Front wheel	2	25	10225	Screw M6*100	1
3	10203	Inner screw	4	26	10226	Arm	2
4	10204	Inner screw M6*16	1	27	10227	Shaft of pipe	1
5	10205	Connection port	1	28	10228	wheel	1
6	10206	Electric assembly	1	29	10229	Bearing 60101	2
7	10207	Inner screw	2	30	10230	Right supporting	1
8	10208	battery	2	31	10231	Retaining ring M10	1
9	10209	Inner screw	2	32	10232	Assembly of reducer	1
10	10210	Right cover	1	33	10233	“H” screw M5*12	3
11	10211	Rear wheel	2	34	10234	Driving wheel	1
12	10212	Screw M8*15	2	35	10235	Flat key A 4*38	1
13	10213	Left cover	1	36	10236	Washer	2
14	10214	Nut M8	1	37	10237	Bearing 80101	1
15	10215	Elastic washer 8	1	38	10238	Left supporting	1
16	10216	Screw M8*60	1	39	10239	Inner screw	4
17	10217	Nut M6	2	40	10240	Bearing seat	1
18	10218	Elastic washer 6	2	41	10241	roller	1
19	10219	Screw M6*20	2	42	10242	Pipe	1
20	10220	Screw M6*86	1	43	10243	Back cover	1
21	10221	Elastic washer 8	1	44	10244	Screw M6*16	2
22	10222	Nut M6	1	45	10245	Switch	1
23	10223	Spring	2				

circuit diagram



No	code	name	No	Code	name
1	U	charger	6	GB1□GB2	battery
2	XS	Socket	7	FU	fuse
3	Et	controller	8	SH1□SH2	magnetic switch
4	HL	pilot lamp	9	SB1□SB2	Micoswitch
5	SA	switch	10	Mp	Motor

Wiring diagram

c

