

DC POWERED ALUMINUM QUICK LIFT - PEL-100A-D3

APPROX WEIGHT: 149.87 lbs.
 DOES NOT INCLUDE WEIGHT OF POWER OR PACKAGING!!!

*** ANY ADDITIONS, DELETIONS, OR OMISSIONS MUST BE CORRECTED ON THIS DRAWING AS THIS DRAWING WILL BE CONSIDERED ALL INCLUSIVE ***

ALL GRAPHICS PROVIDED ARE FOR REFERENCE ONLY. IF CERTAIN DIMENSIONS ARE CRITICAL PLEASE VERIFY THOSE DIMENSIONS WITH YOUR SALESPERSON

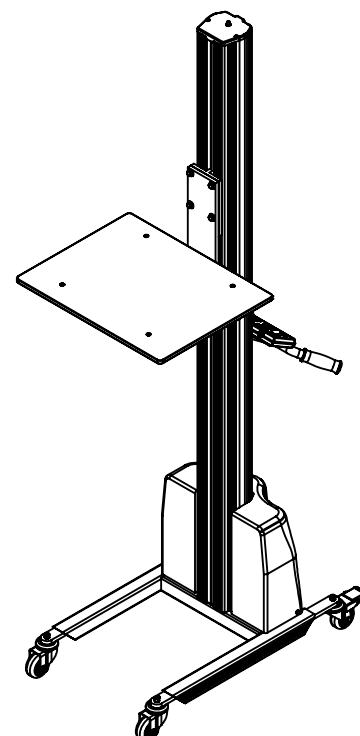
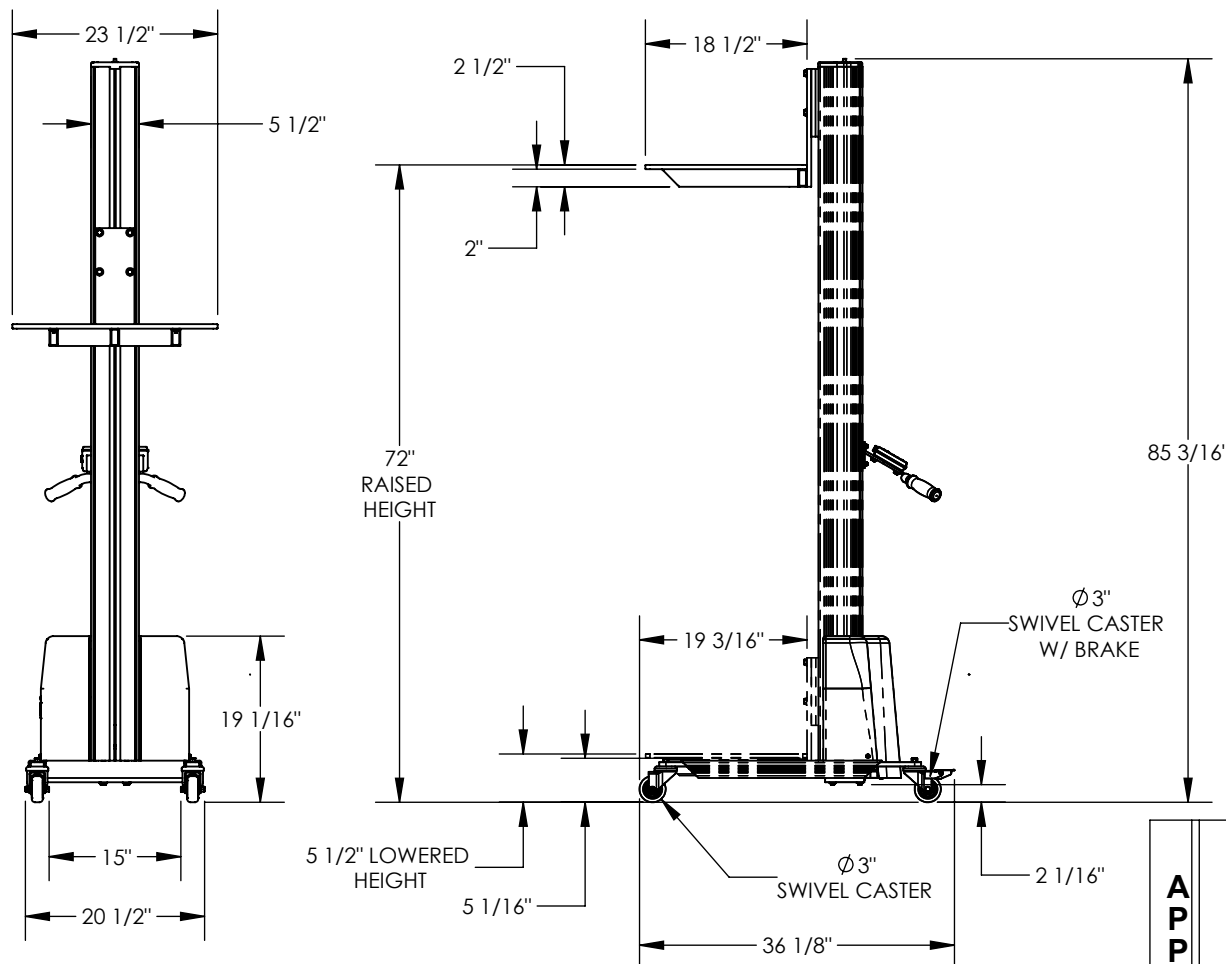

DIMENSION TOLERANCE ± 1/4"

STANDARD FEATURES

- MODEL NUMBER IS PEL-100A-D3
- ALUMINUM CONSTRUCTION
- PLATFORM WIDTH 23 1/2"
- PLATFORM LENGTH IS 18 1/2"
- LOWERED HEIGHT IS 5 1/2"
- RAISED HEIGHT IS 72"
- 24V DC POWER
- MAX CAPACITY IS 125 LBS.
- Ø 3" POLY ON POLY STEM CASTERS
- 2 SWIVEL W/ BRAKE & 2 SWIVEL

SPECIAL FEATURES

NONE

APPROVAL

I, THE UNDERSIGNED, AGREE THAT THE PRODUCT AS REPRESENTED SATISFIES DESIGN AND DIMENSION REQUIREMENTS. I ALSO ACKNOWLEDGE MY DUTY TO CONFIRM PRODUCT AND INSTALLATION COMPLIANCE WITH ALL APPLICABLE FEDERAL, STATE AND LOCAL REGULATIONS AND STANDARDS.

UNITS REQUIRING APPROVAL DRAWINGS OR MODIFIED ARE NON-RETURNABLE

[] As drawn [] As marked

Signed: _____ Date: _____

Printed Name: _____

LEAD TIME WILL START UPON RECEIPT OF SIGNED APPROVAL DRAWING

DISTRIBUTOR'S NAME:		P.O.#
VESTIL MANUFACTURING		X
DRAWN BY: KJY	DATE: 07/09/13	W.O.#
REFERENCE: X	SCALE: 1:22	X
QUOTED LEAD TIME: X	QUOTE #	FILE NAME:
	X	42-007-003