



VESTIL MANUFACTURING CORP.
 2999 North Wayne Street, P.O. Box 507, Angola, IN 46703
 Telephone: (260) 665-7586 -or- Toll Free (800) 348-0868
 Fax: (260) 665-1339
 www.vestilmfg.com e-mail: info@vestil.com

HIPM Series High Rise Skid Trucks Instruction Manual



RECEIVING INSTRUCTIONS:

After delivery, IMMEDIATELY remove the packaging from the product. Inspect the product closely to determine whether it sustained damage during transport. If damage is discovered, record a complete description of it on the bill of lading and notify the freight carrier. If the product is undamaged, discard the packaging.

NOTE:

The end-user is solely responsible for confirming that product design, installation, use, and maintenance comply with laws, regulations, codes, and mandatory standards applied where the product is used.

Table of Contents

Specifications.....	2
Signal words.....	2
Safe use recommendations.....	2
FIGS. 1-2: Exploded parts diagrams and bills of materials.....	3
FIGS. 3A-3E: DC (battery powered) electrical system diagrams.....	4 – 6
FIGS. 4A-4D: AC modular power unit diagrams.....	7 – 8
FIG. 5: 115VAC single phase electrical circuit diagram.....	9
FIG. 6: 208/230VAC single phase electrical circuit diagram.....	9
FIG. 7: 115VAC 3-phase electrical circuit diagram.....	10
Hydraulic circuit diagram and hydraulic system operation.....	11 - 12
Hydraulic system troubleshooting guide.....	12 - 13
Inspections.....	13 - 14
Maintenance.....	14
Battery charger operation (DC units).....	14
Labeling diagram.....	15
Limited warranty.....	16

Specifications:

Crane dimensions and net weight appear in the table below.

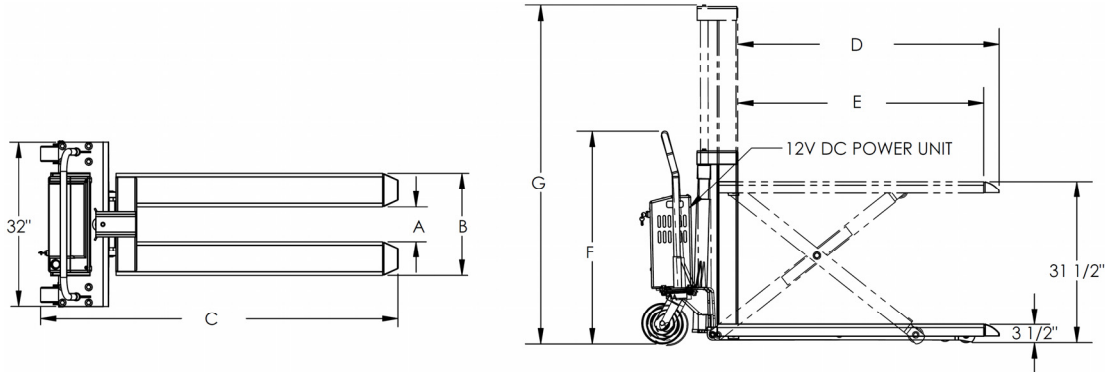

Model	A	B	C	D	E	F	G	Capacity	Net wt.
HIPM-2772-DC	11"	27"	91 ¹¹ / ₃₂ "	72"	N/A	41 ⁵ / ₈ "	66 ¹ / ₂ "	2,500 lb.	828 lb.
HIPM-2772-AC	11"	27"	91 ¹¹ / ₃₂ "	72"	N/A	41 ⁵ / ₈ "	66 ¹ / ₂ "	2,500 lb.	828 lb.
HIPM-2772-AIR	11"	27"	91 ¹¹ / ₃₂ "	72"	N/A	41 ⁵ / ₈ "	66 ¹ / ₂ "	2,500 lb.	828 lb.
HIPM-2748-DC	13 ³ / ₄ "	27"	69 ⁷ / ₁₆ "	51"	48"	41 ¹ / ₂ "	65 ¹⁵ / ₁₆ "	2,500 lb.	530 lb.
HIPM-2748-AC	13 ³ / ₄ "	27"	69 ⁷ / ₁₆ "	51"	48"	41 ¹ / ₂ "	65 ¹⁵ / ₁₆ "	2,500 lb.	530 lb.
HIPM-2748-AIR	13 ³ / ₄ "	27"	69 ⁷ / ₁₆ "	51"	48"	41 ¹ / ₂ "	65 ¹⁵ / ₁₆ "	2,500 lb.	530 lb.
HIPM-2048-DC	6 ³ / ₄ "	20"	69 ⁷ / ₁₆ "	51"	48"	41 ¹ / ₂ "	66"	2,500 lb.	514 lb.
HIPM-2048-AC	6 ³ / ₄ "	20"	69 ⁷ / ₁₆ "	51"	48"	41 ¹ / ₂ "	66"	2,500 lb.	514 lb.
HIPM-2048-AIR	6 ³ / ₄ "	20"	69 ⁷ / ₁₆ "	51"	48"	41 ¹ / ₂ "	66"	2,500 lb.	514 lb.

Signal Words:

This manual uses SIGNAL WORDS to call attention to uses of this product that are likely to result in personal injuries or property damage. The signal words used in this manual appear below along with their definitions.



Identifies a hazardous situation which, if not avoided, WILL result in DEATH or SERIOUS INJURY. Use of this signal word is limited to the most extreme situations.



Identifies a hazardous situation which, if not avoided, COULD result in DEATH or SERIOUS INJURY.



Indicates a hazardous situation which, if not avoided, COULD result in MINOR or MODERATE injury.



Identifies practices likely to result in product/property damage, such as operation that might damage the product or other property.

Safe Use Recommendations:

Study the entire manual before using this crane. Read the manual to refresh your understanding of the safe operation, inspection or maintenance procedures whenever necessary.



Improper or careless operation might result in serious personal injuries.

- DO NOT use this truck if it is damaged or malfunctioning! Restore it to normal operating condition before returning it to service.
- DO NOT exceed the capacity of your unit (see "Specifications" table above). Center and evenly distribute all loads applied to the forks. Loads must rest firmly against the upright frame.
- ONLY raise the forks a few inches to transport loads.
- DO NOT reach into the scissor leg mechanism, especially while a load is applied to the forks. Keep clothing away from pivot points during operation.
- ONLY use this lifter on even, level surfaces. DO NOT move loads up or down inclines with this truck.
- This product is a material handling truck. DO NOT use it to lift or carry people.
- DO NOT use the truck if any label is unreadable, damaged, or missing (see "Labeling diagram" on p. 15). Contact Vestil for replacement labels.
- DO NOT modify the crane! Modifications automatically void the limited warranty (see p. 16) and might make the lifter unsafe to use.

FIG. 1A: HIPM-2048 Exploded Parts Diagram and Bill of Materials

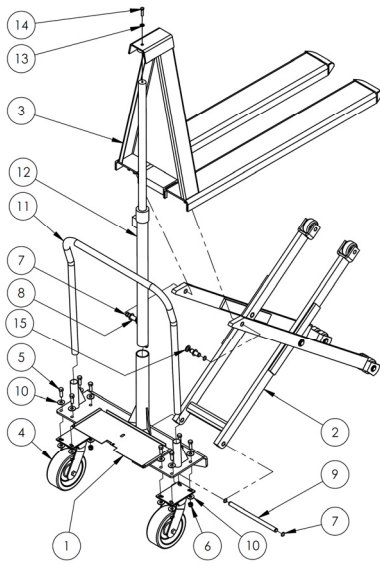

Item	Part No.	Description	Qty.
1	15-514-019	Weldment, frame, base	1
2	15-510-014	Weldment, leg assembly	1
3	15-514-033	Weldment, frame, platform	1
4	15-112-007	Pin, inner leg hinge	1
5	16-132-171	8" x 3" phenolic swivel	2
6	68015	External retaining ring, phosphate, $\frac{3}{4}$ "	6
7	11209	$\frac{1}{2}$ " - 13 x $1\frac{1}{2}$ " HHCS, ASTM A307, Grade A, zinc-plated	8
8	37030	$\frac{1}{2}$ " - 13 Nylock insert lock nut	8
9	15-112-006	Pin, hinge	2
10	33012	Flat washer, low carbon, zinc finish, $\frac{1}{2}$ "	16
11	16-025-028	Handle, chromed	1
12	99-021-927	Cylinder, telescopic, 28" stroke	1
13	33008	Flat washer, low carbon, USS, zinc plated, $\frac{3}{8}$ "	1
14	11109	Hex bolt, grade A, zinc finish, $\frac{3}{8}$ " - 16 x $1\frac{1}{2}$ "	1
15	33424	Machine bushing, low carbon, plain finish, $\frac{3}{4}$ " x 18ga.	6

FIG. 1B: HIPM-2748 Exploded Parts Diagram and Bill of Materials

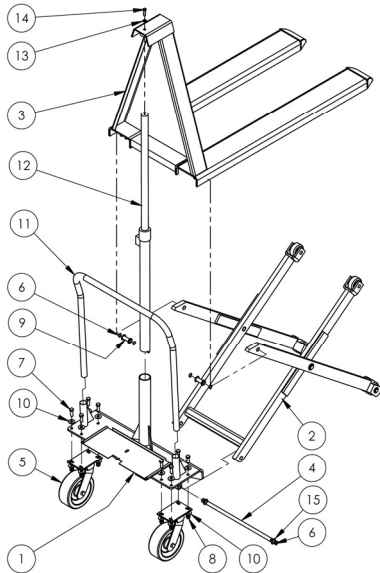

Item	Part No.	Description	Qty.
1	15-514-022	Weldment, frame, base	1
2	15-510-015	Weldment, leg assembly	1
3	15-514-034	Weldment, frame, platform	1
4	16-132-171	8" x 3" phenolic swivel	2
5	11209	$\frac{1}{2}$ " - 13 x $1\frac{1}{2}$ " HHCS, ASTM A307, Gr. A, zinc-plated	8
6	37030	$\frac{1}{2}$ " - 13 Nylock insert lock nut	8
7	68015	External retaining ring, phosphate, $\frac{3}{4}$ "	6
8	15-112-006	Pin, hinge	2
9	15-112-009	Pin, inner leg hinge	1
10	33012	Flat washer, low carbon, zinc finish, $\frac{1}{2}$ "	16
11	16-025-028	Handle, chromed	1
12	99-021-927	Cylinder, telescopic, 28" stroke	1
13	33008	Flat washer, low carbon, USS, zinc plated, $\frac{3}{8}$ "	1
14	11109	Hex bolt, grade A, zinc finish, $\frac{3}{8}$ " - 16 x $1\frac{1}{2}$ "	1
15	33424	Machine bushing, low carbon, plain finish, $\frac{3}{4}$ " x 18ga.	6

FIG. 2: HIPM-2772 Exploded Parts Diagram and Bill of Materials

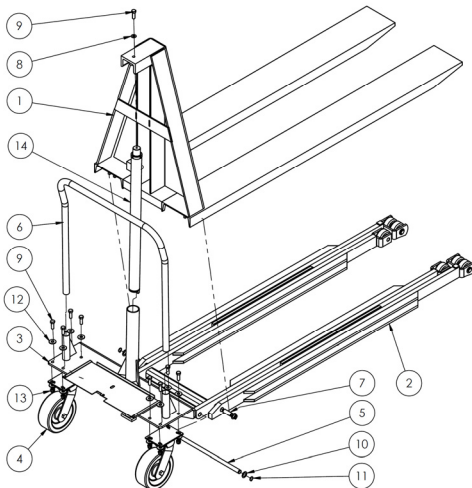

Item	Part No.	Description	Qty.
1	15-514-022	Weldment, frame, base	1
2	15-510-015	Weldment, leg assembly	1
3	15-514-034	Weldment, frame, platform	1
4	16-132-171	8" x 3" phenolic swivel	2
5	11209	$\frac{1}{2}$ " - 13 x $1\frac{1}{2}$ " HHCS, ASTM A307, Gr. A, zinc-plated	8
6	37030	$\frac{1}{2}$ " - 13 Nylock insert lock nut	8
7	68015	External retaining ring, phosphate, $\frac{3}{4}$ "	6
8	15-112-006	Pin, hinge	2
9	15-112-009	Pin, inner leg hinge	1
10	33012	Flat washer, low carbon, zinc finish, $\frac{1}{2}$ "	16
11	16-025-028	Handle, chromed	1
12	99-021-927	Cylinder, telescopic, 28" stroke	1
13	33008	Flat washer, low carbon, USS, zinc plated, $\frac{3}{8}$ "	1
14	11109	Hex bolt, grade A, zinc finish, $\frac{3}{8}$ " - 16 x $1\frac{1}{2}$ "	1
15	33424	Machine bushing, low carbon, plain finish, $\frac{3}{4}$ " x 18ga.	6

FIG. 3A: DC modular power unit exploded parts diagram and parts list

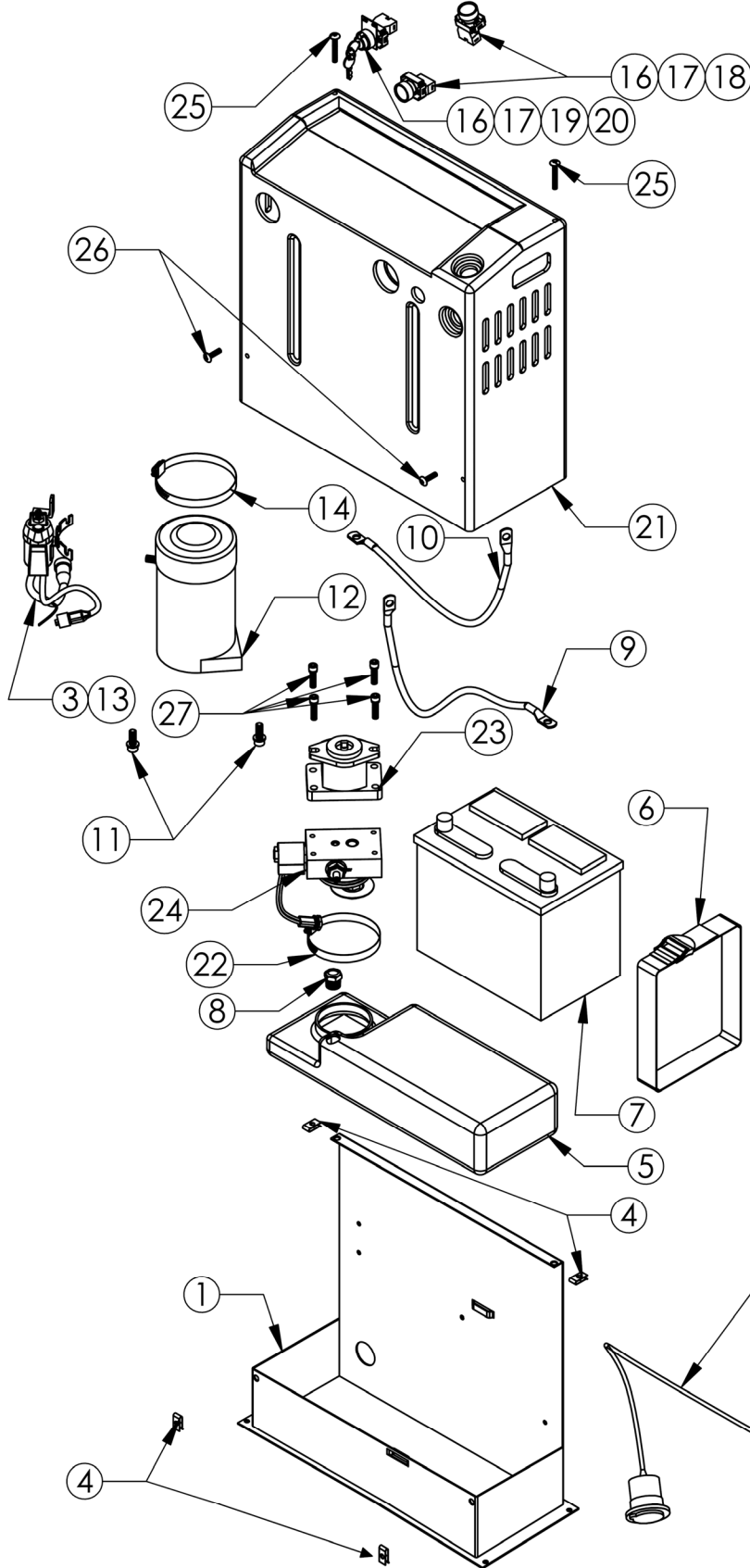

Item no.	Part no.	Description	Quantity
1	99-016-933	Base bracket	1
2	21-034-008	Charger (Soniel)	1
3	01-033-024	24", 18/3, 4-pin plug	1
4	37927	Tinnerman clip	4
5	99-023-001	Reservoir	1
6	99-034-013	Battery strap	1
7	24DC36	Battery	1
8	BV-48	Breather	1
9	15-533-013	Cable, battery, 23" black	1
10	15-533-014	Cable, battery, 23" red	1
11	23305	$\frac{3}{8}$ " - 16 x 1" utility grade bolt	2
	33688	$\frac{3}{8}$ " high collar lock washer	2
	33008	$\frac{3}{8}$ " flat washer	2
12	99-135-011	4", 12VDC motor w/ tang dr.	1
13	15-022-004	12V start solenoid relay	1
14	HS64	Worm gear hose clamp	1
15	BG-12V	Battery gauge	1
16	ZB2BZ009	Base, contact block	3
17	ZB2BE101	Contact block N.O.	3
18	ZB2BA2C	Operator, black, non-illuminated	2
19	ZB2BG4C	Key switch, 2-position	1
20	01-134-007	Legend, ON - OFF	1
21	091802JY	Fiberglass cover	1
22	HS52	Clamp, worm gear	1
23	01-143-906	Pump	1
24	01-627-010	Manifold assembly (exploded view on p. 12)	1
25	29201	$\frac{1}{4}$ in. - 20 x $1\frac{3}{4}$ in. TPHMS zinc-plated	2
26	29185	$\frac{1}{4}$ in. - 20 x 1in. TPHMS zinc-plated	2
27	23255	SHCS utility grade	4
	33687	High collar lock washer	4
28	152400-03	Molded cord	1
29	150CCTM.OEM	Connector, charge	1
30	3MT ST3540	1in. hook and loop press	10"

FIG. 3B: Exploded view of DC manifold assembly (item no. 24 in FIG. 3A)

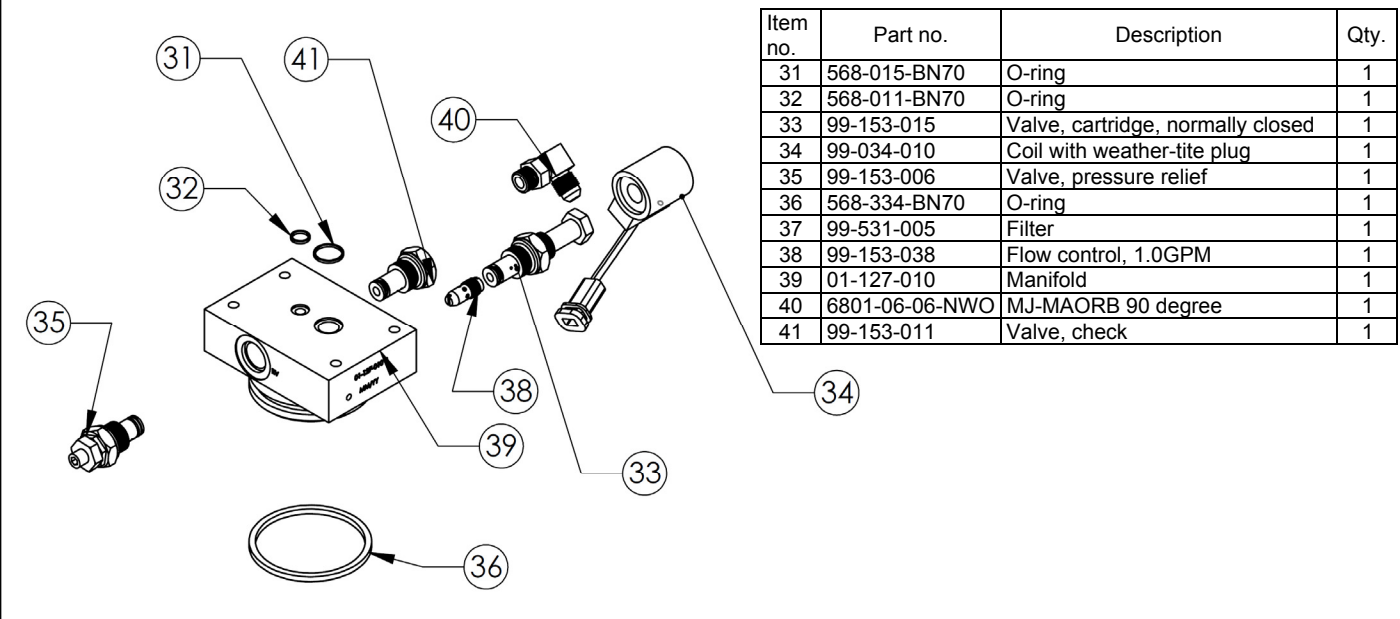

FIG. 3C: 12 VDC modular power unit electrical circuit diagram

99-124-026, Rev. D

****Overcurrent & short circuit protection as well as system disconnect must be provided by the end user.****

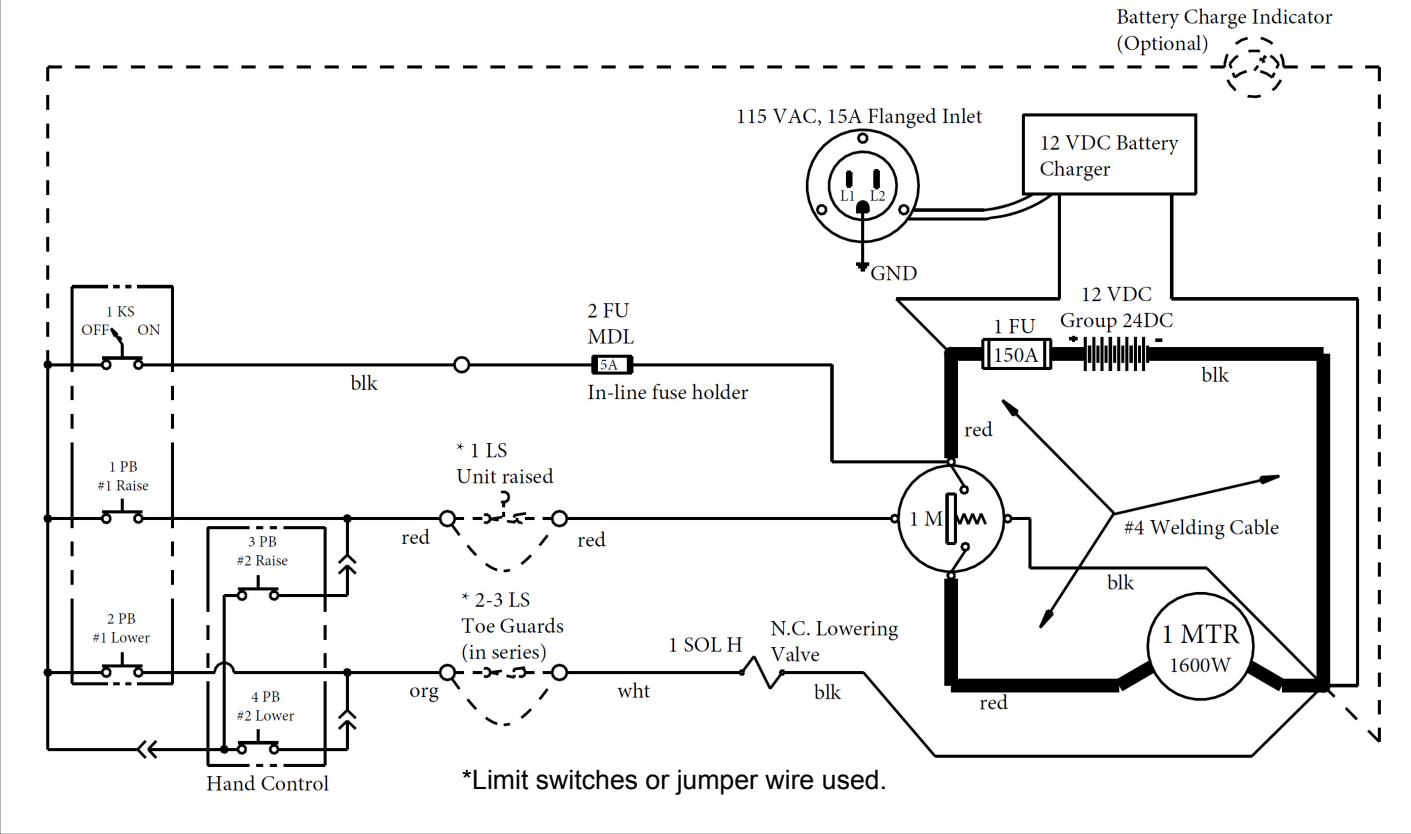

FIG. 3D: 12VDC modular power unit layout (part 1 of 2)

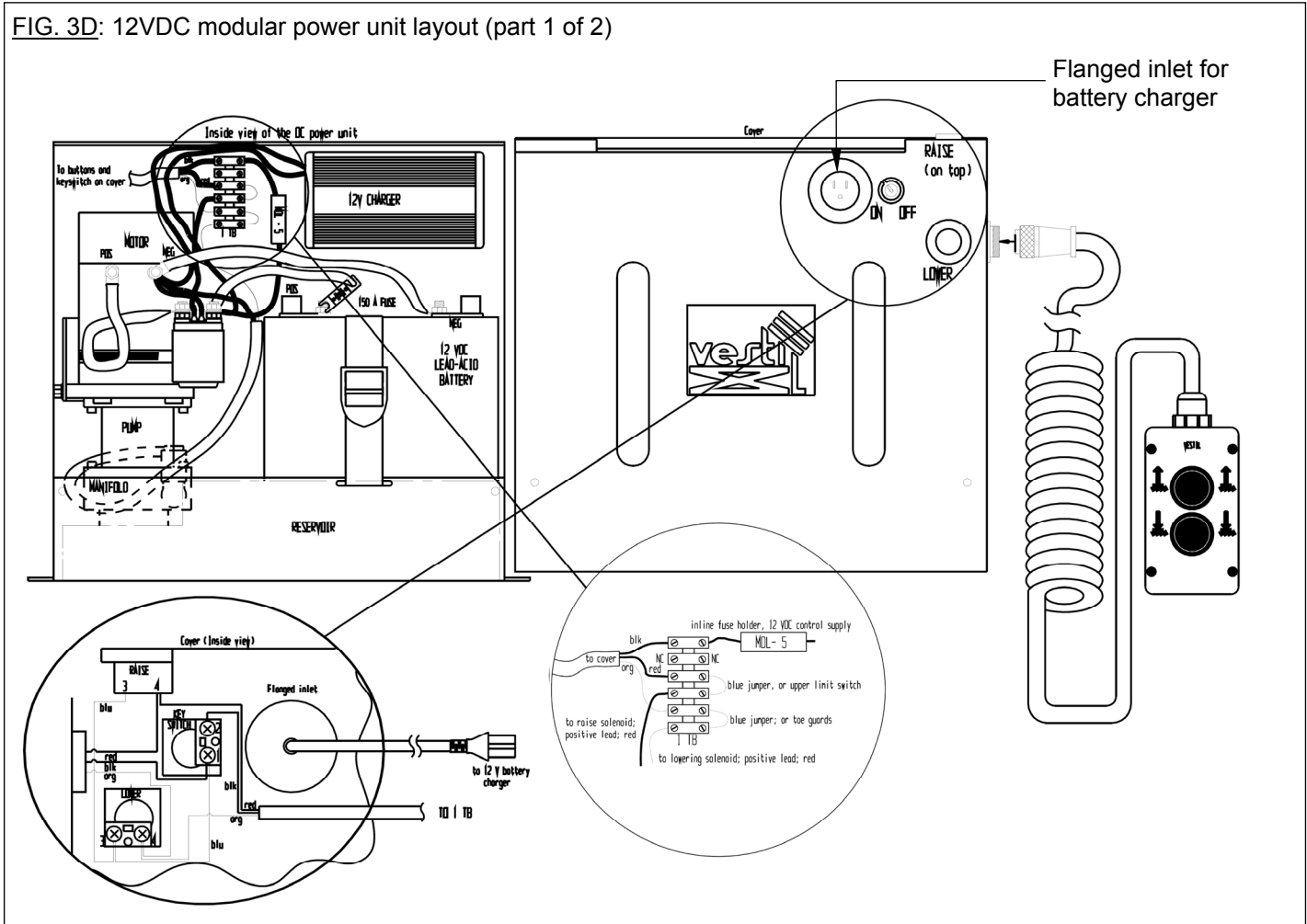

FIG. 3E: 12VDC modular power unit layout (part 2 of 2)

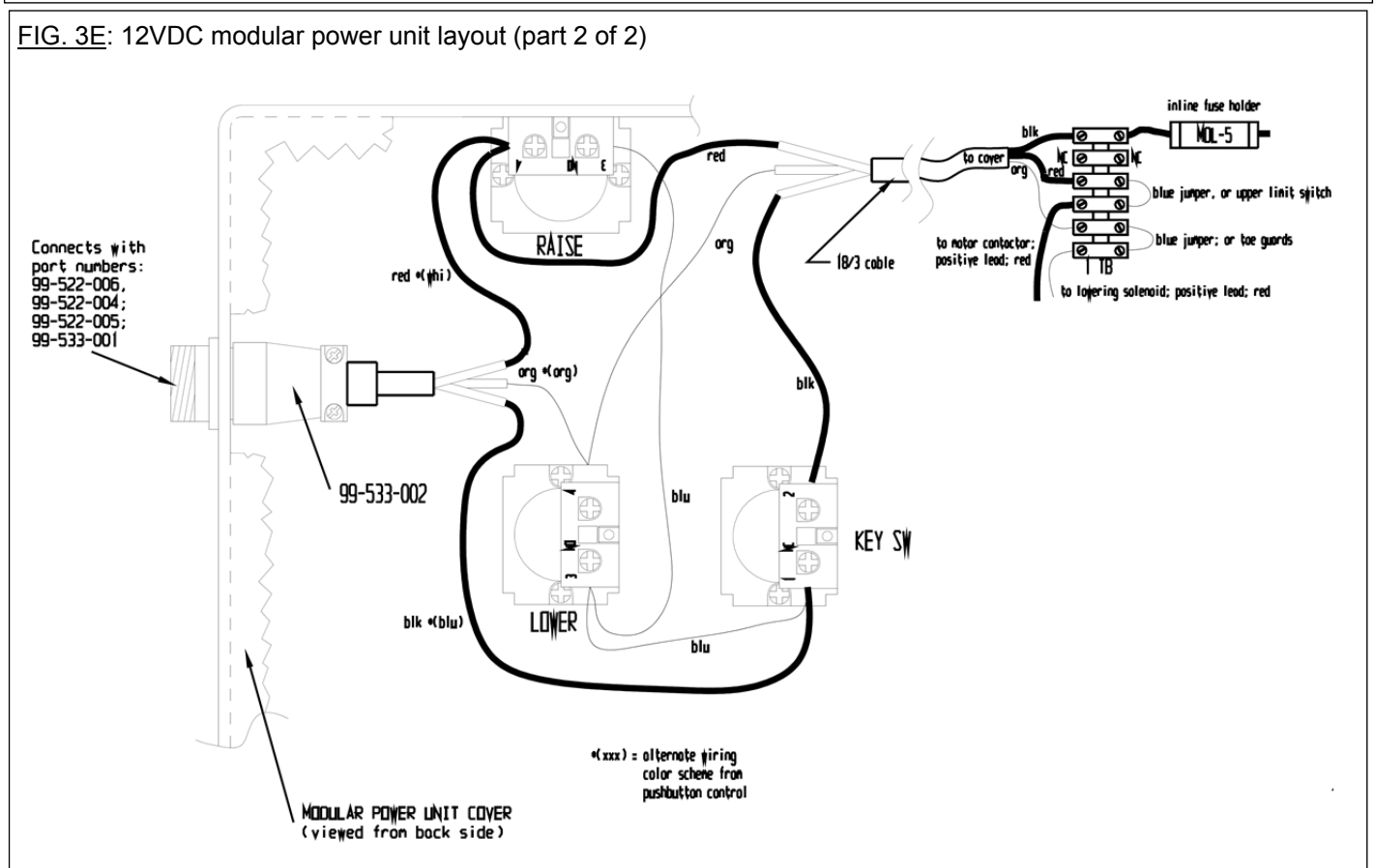
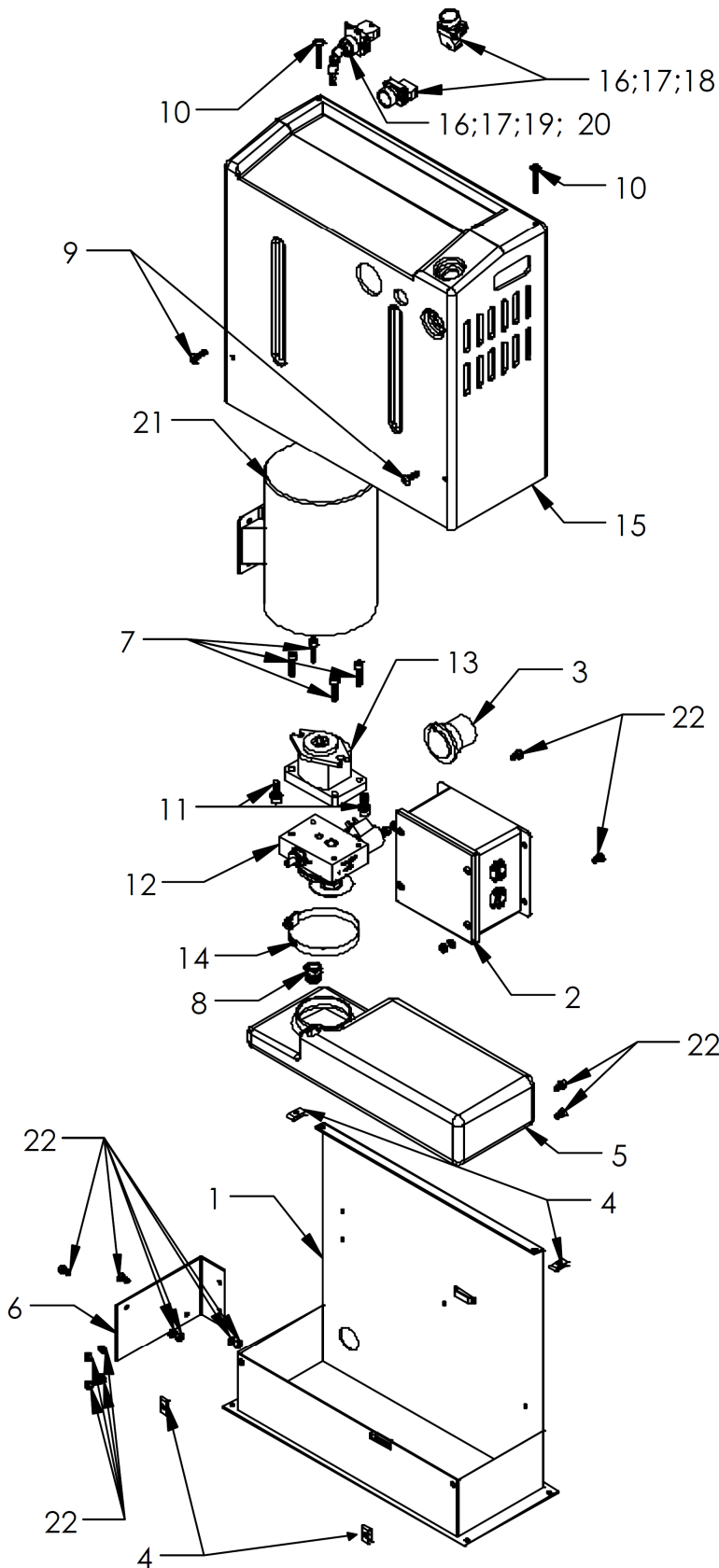
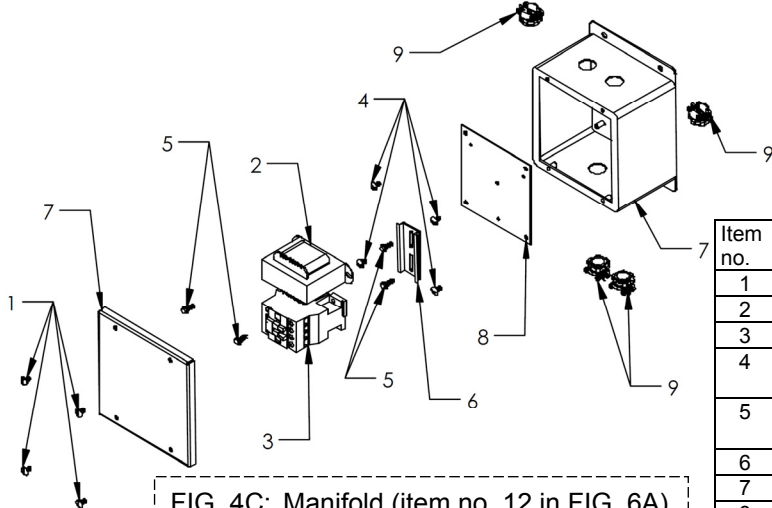

FIG. 4A: AC modular power unit exploded parts diagram and parts list



Item no.	Part no.	Description	Quantity
1	99-016-933	Base bracket	1
2	21-034-008	Electrical box (see FIG. 6B)	1
3	21-034-005	AC adaptor plug	1
4	37927	Tinnerman clip	4
5	99-023-001	Reservoir	1
6		Motor brace	1
7	23255 33687	$\frac{5}{16}$ " - 18 x 1" utility grade bolt $\frac{5}{16}$ " high collar lock washer	4 4
8	BV-48	Breather	1
9	29185	$\frac{1}{4}$ " - 20 x 1" TPHMS z-plated screw	1
10	29201	$\frac{1}{4}$ " - 20 x $1\frac{3}{4}$ " TPHMS z-plated screw	1
11	23305 33688 33008	$\frac{3}{8}$ " - 16 x 1" utility grade bolt $\frac{3}{8}$ " high collar lock washer $\frac{3}{8}$ " flat washer	2 2 2
12	01-627-010	Manifold (see FIG. 6C)	1
13	01-143-906	Pump	1
14	HS52	Worm gear hose clamp	1
15	091802JY	Fiberglass cover	1
16	ZB2BZ009	Base, contact block	3
17	ZB2BE101	Contact block N.O.	3
18	ZB2BA2C	Operator, black, non-illuminated	2
19	ZB2BG4C	Key switch, 2-position	1
20	01-134-007	Legend, ON - OFF	1
21			1
22	HS52	Clamp, worm gear	1
23	01-143-906	Pump	1
24	01-627-010	Manifold assembly (exploded view on p. 12)	1
25	29201	$\frac{1}{4}$ in. - 20 x $1\frac{3}{4}$ in. TPHMS zinc-plated	2
26	29185	$\frac{1}{4}$ in. - 20 x 1in. TPHMS zinc-plated	2
27	23255 33687	SHCS utility grade High collar lock washer	4 4
28	152400-03	Molded cord	1
29	150CCTM.OEM	Connector, charge	1
30	3MT ST3540	1in. hook and loop press	10"

FIG. 4B: Electrical box (Item no. 2 in FIG. 5A)



Item no.	Part no.	Description	Quantity
1	71616	10 – 32 x ⁵ / ₁₆ " TSHMS screws	4
2	01-129-001	Transformer	1
3	132560	Motor contactor	1
4	27531	10 – 32 x ¹ / ₄ " PSHMS zinc-plated screws	4
5	32028	8 – 18 x ¹ / ₂ " HWH TEK drill and tap screws	4
6	TB-TRACK	Aluminum din rail	3"
7	01-029-006	⁵ / ₁₆ " – 18 x 1" utility grade bolt	1
8	AB66JP	6" x 6" enclosure plate	1
9	C500	³ / ₈ " (¹ / ₂ " knockout) Romex 2-screw NM clamp connector	4
10	01-127-010	LHL standard manifold, 3" boss	1
11	6801-06-06-NOW	³ / ₈ " – 16 x 1" utility grade bolt	2
12	99-153-011	Check valve	1
13	568-015-BN70	O-ring	1
14	568-011-BN70	O-ring	1
15	99-153-015	Normally closed cartridge valve	1
16	99-034-008	24VAC coil	1
17	99-153-006	Pressure relief valve	1
18	568-334-BN70	O-ring	1
19	99-531-005	Filter	1
20	99-153-038	Flow control, 1.0GPM	1

FIG. 4C: Manifold (item no. 12 in FIG. 6A)

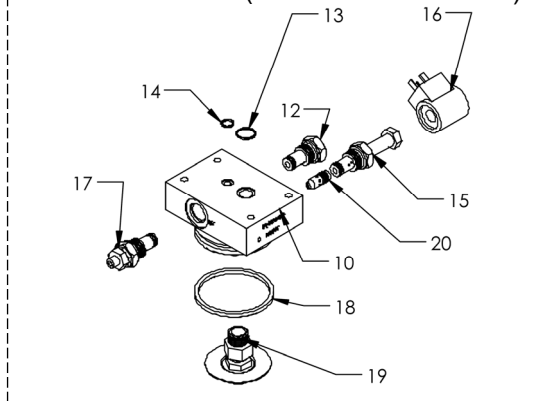

FIG. 4D: AC modular power unit layout

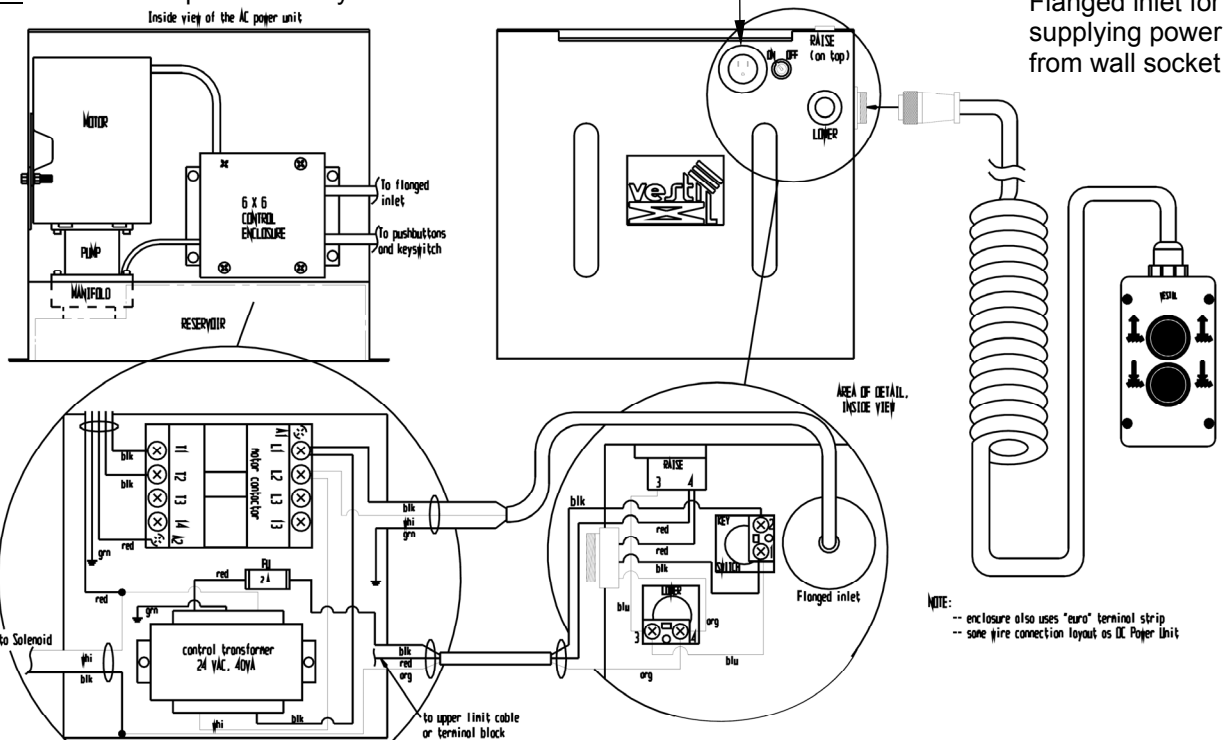
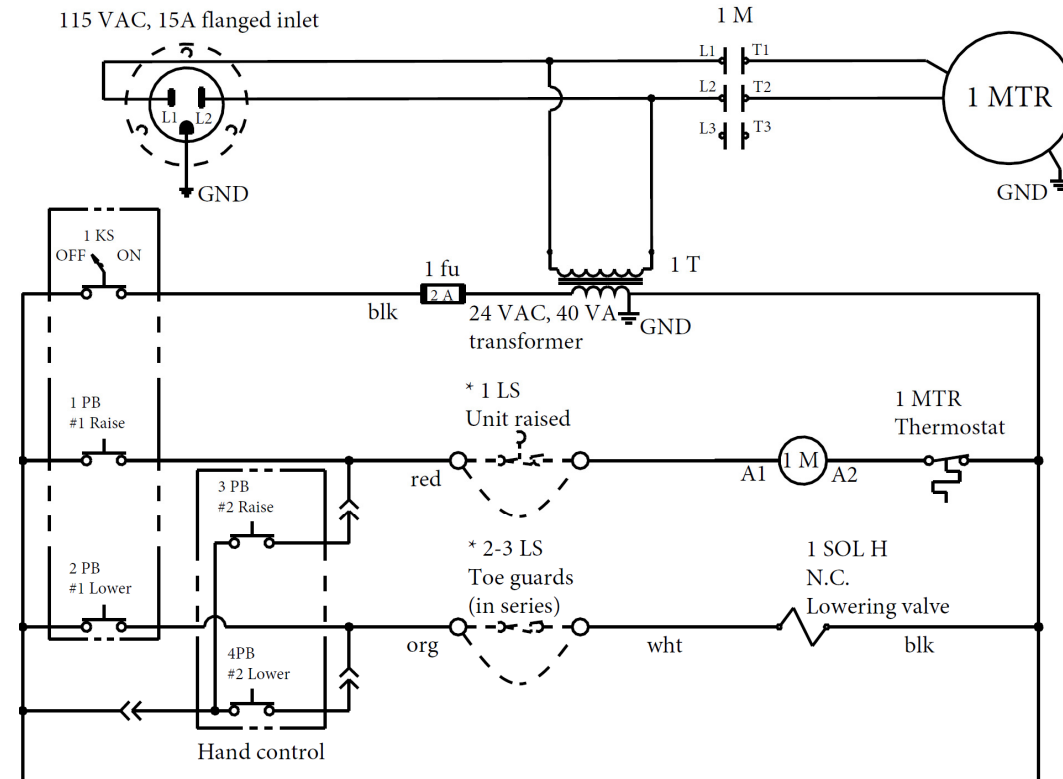

FIG. 5: 115 VAC, single phase modular power unit electrical circuit diagram

99-124-026, Rev. D



NOTE:
Overcurrent and short-circuit protection consistent with the National Electrical Code must be provided by the end user.

*Limit switches or jumper wire used.

FIG. 6: 208/230 VAC, single phase modular power unit electrical circuit diagram

99-124-033

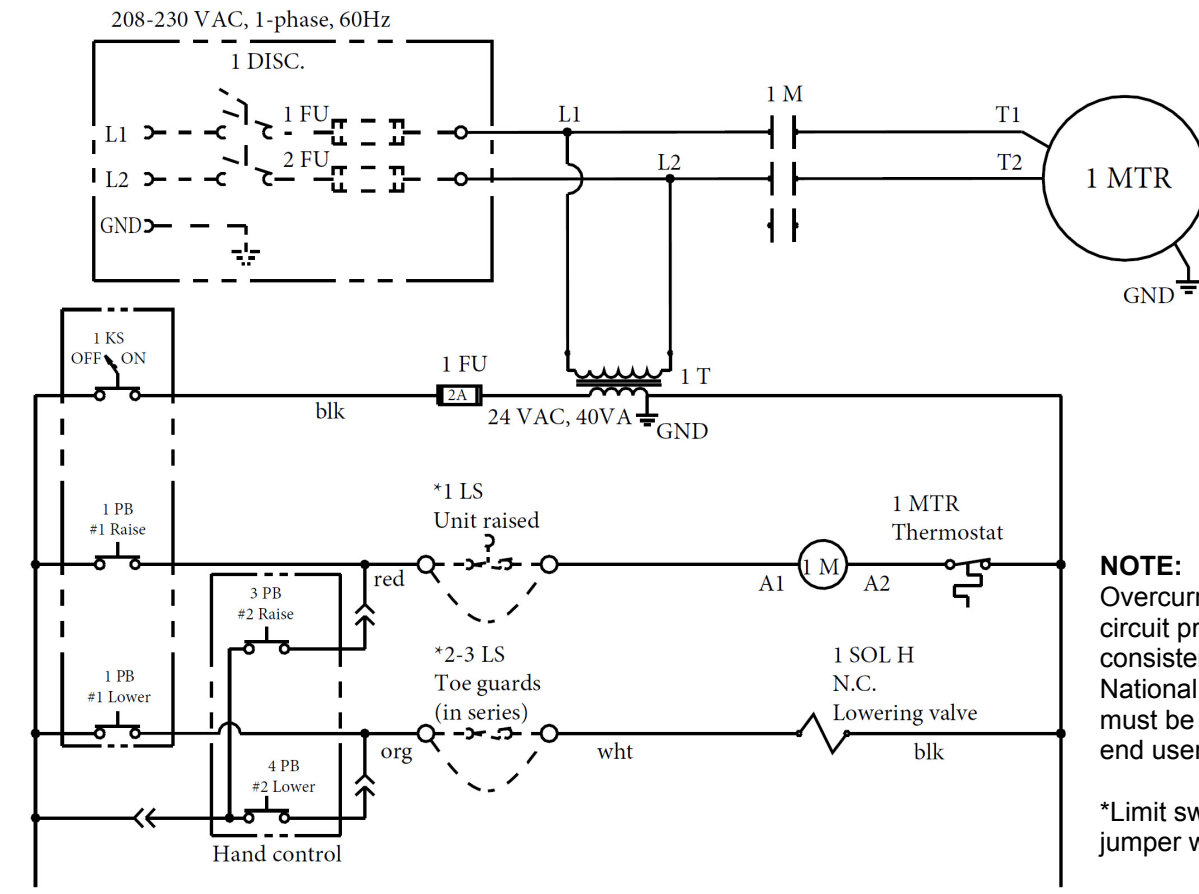

NOTE:
Overcurrent and short-circuit protection consistent with the National Electrical Code must be provided by the end user.

*Limit switches or jumper wire used.

FIG. 7: 115 VAC, 3-phase modular power unit electrical circuit diagram

99-124-032

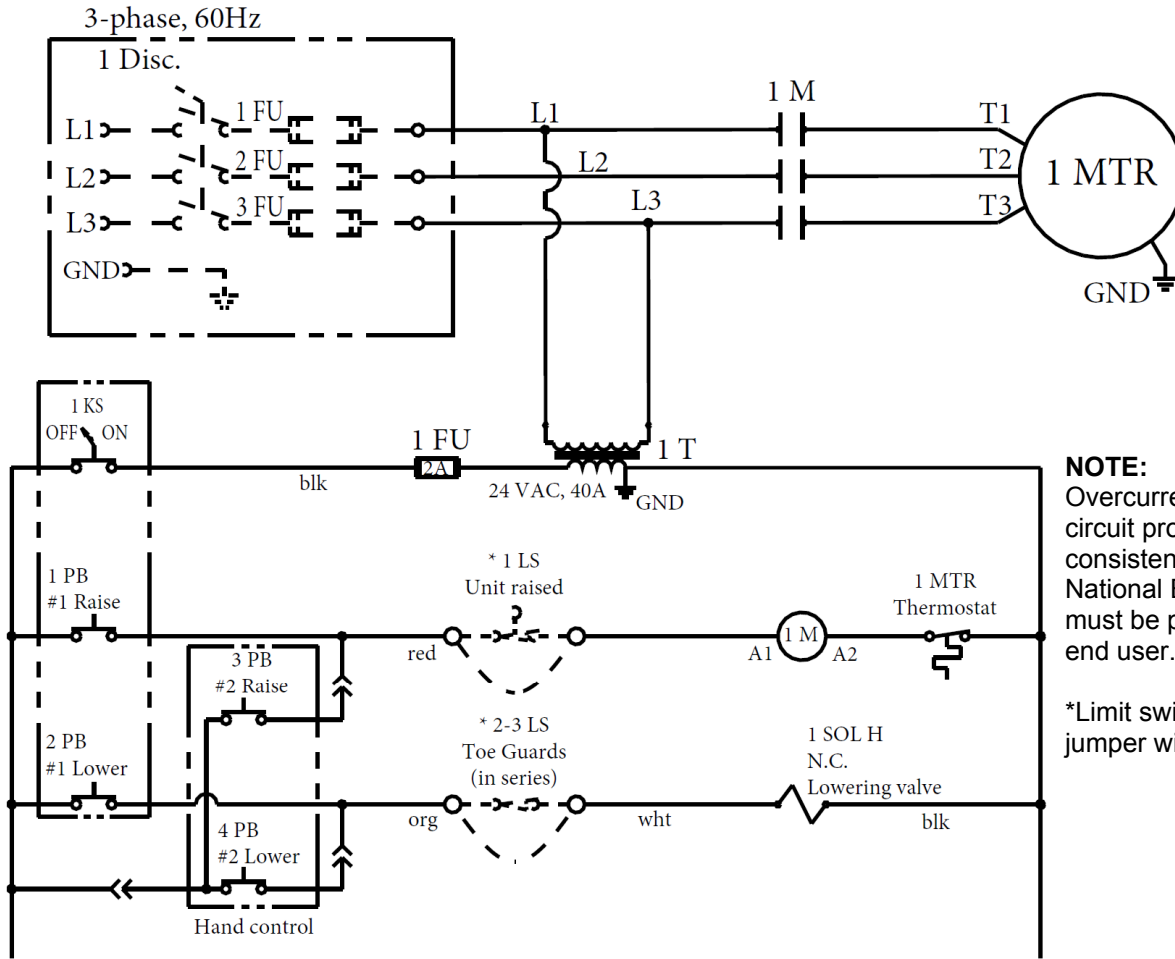

NOTE:
Overcurrent and short-circuit protection consistent with the National Electrical Code must be provided by the end user.

*Limit switches or jumper wire used.

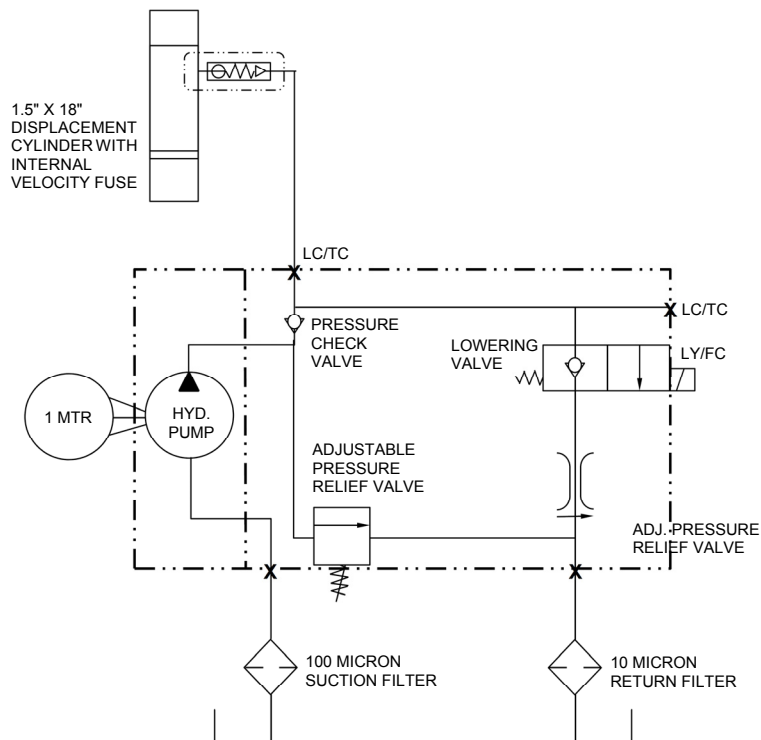
Hydraulic circuit diagram

Operation: (AC powered units must be plugged into a wall outlet via the flanged inlet. See FIG. 4D on p. 8).

To raise the forks, press the white (UP) button on the hand control. Pressing the button activates the electric motor, which turns the hydraulic pump. When the pump spins, oil is drawn out of the reservoir (inside the power unit). It flows through a suction filter and into the pump. Pressurized oil then flows from the pump, through a check valve (to prevent back flow when the pump is not running), and into the cylinder. Oil remains in the cylinder allowing the forks to maintain elevation after the UP button is released.

If the weight of the load applied to the forks exceeds the capacity of the lifter, the forks will not rise even though the UP button is pressed. Pressure will increase in the hydraulic circuit between the pump and the cylinder. When pressure reaches a preset level, a relief valve unseats and allows oil to circulate back to the reservoir. Redirecting oil during an overload situation prevents oil pressure from continuing to increase. Extremely high pressure might damage the hydraulic system, for example hose ruptures.

To lower the forks, press the black (DOWN) button. This energizes the lowering solenoid valve coil, unseats the poppet valve, and allows oil to return to the reservoir. As oil flows from the cylinders, it passes through a pressure compensated flow control valve (PCFC). The PCFC limits the amount of oil leaving the cylinders. Limiting flow ensures that the forks descend at a constant, controlled rate.

Releasing the DOWN button de-energizes the solenoid and closes the valve poppet. Both the closed poppet and the check valve work to prevent oil from returning to the reservoir. Consequently, the cylinder stops retracting and the forks maintain their positions.

Lowering valve maintenance:

The lifter is equipped with a cartridge lowering valve that requires virtually no maintenance. However, the valve might occasionally require cleaning. To clean the valve, lower the forks completely. Remove the valve and follow steps 1-4 below:

1. Use a thin tool to push the poppet in from the bottom to open the valve and then release it. Repeat several times while immersing the valve in mineral spirits or kerosene.
2. Dry the valve. Blow compressed air through it while holding the poppet open as described in step 1.
3. Inspect all O-rings and the PTFE (polytetrafluoroethylene) washer. Replace any component that is nicked, torn, cut, etc. Only use manufacturer approved replacement parts.
4. Reinstall the valve. Tighten the valve to ~20ft-lb with a torque wrench.

Velocity fuse:

Inside the base of the cylinder is a brass velocity fuse with a stainless steel spring. The fuse is a safety feature that activates if a hose or fitting fails causing rapid depressurization of the hydraulic circuit. Without the velocity fuse, the forks would lower dangerously quickly. By including a velocity fuse, oil cannot flow out of the cylinder if oil flow rate equals or exceeds a preset rate. The forks maintain position while the fuse is closed.

NOTE: The presence of air in the system can cause the velocity fuse to lock up even though no failure has occurred. To reset the velocity fuse, activate the pump by pressing and releasing the white button several times. Remove the load and cycle the forks up and down several times to purge air from the circuit.

Air bleeding procedure:

If the forks descend very slowly or will not lower at all, air is probably trapped somewhere in the hydraulic circuit and must be bled from the system. Air can be bled from a “bleeder” screw located at the top of the cylinder. To bleed air from the system:

1. Loosen the bleeder screw by $\frac{1}{4}$ to $\frac{1}{2}$ a turn to allow trapped air to escape. Press the foot pump treadle (manual units) or jog the motor (powered units) to push air out of the hydraulic circuit.
2. When the cylinder is purged of air only clear hydraulic fluid will flow from the bleeder opening. Tighten the screw to close the opening.

Hydraulic System Troubleshooting Guide:

Contact the manufacturer to discuss issues not identified in the table below.

Observation	Possible Cause	Remedy
1. Forks do not raise even though pump is running.	<ol style="list-style-type: none"> a. Voltage at motor terminals too low. b. Hose is leaking. c. Fluid level is low. d. Load exceeds capacity, i.e. relief valve opening. e. Suction filter clogged. f. Suction line leaking air (loose fittings). g. Filler/breather cap on reservoir clogged. h. Lowering valve energized or stuck open. i. Pump malfunctioning. j. Low battery charge (DC units only). 	<ol style="list-style-type: none"> a. Measure voltage at motor terminals (or as close to them as possible) while pump runs under load. If voltage is adequate, check wiring. Refer to the appropriate wiring diagram for your unit (FIGS. 3-7). b. Repair leak(s). c. Add oil to reservoir (for oil specifications, see “Inspections & Maintenance”, p. 13). d. Reduce load to within rated load of lifter. DO NOT CHANGE RELIEF VALVE SETTING! e. Remove filter and clean it. f. Inspect all fittings for proper, leak-tight fit. g. Remove and clean. h. Remove solenoid valve. Check and clean valve (refer to “Hydraulic System Operation” section on p. 11). i. Disconnect hydraulic hose at power unit. Put end of hose in a large container and cycle pump. If no oil output, check pump-motor coupling and correct if necessary. If pump worn, contact manufacturer for replacement parts. j. Stop using lifter and adequately charge battery before returning to service.
2. Forks rise very slowly.	<ol style="list-style-type: none"> k. Debris stuck in lowering solenoid allowing oil to flow to reservoir. l. Debris clogging suction filter or breather cap. m. Pinched hose. n. Low motor voltage. o. Load exceeds capacity of lifter. p. Pump inoperative. q. Low battery charge (DC units). 	<ol style="list-style-type: none"> k. Lower the forks. Remove the solenoid valve and clean (see p. 11). l. Remove and clean filter or breather cap. m. Unkink hose. n. See 1(a). o. See 1(d). p. See 1(i). q. Stop using lifter and charge battery.
3. Motor labors or is extremely hot.	<ol style="list-style-type: none"> r. Voltage at motor terminals too low. s. Incorrect wiring. t. Oil starvation causing pump to bind producing high internal heat. Pump might be permanently damaged. u. Binding cylinder. v. Low battery charge (DC units). 	<ol style="list-style-type: none"> r. See 1(a). s. Specifically check to see if one leg of motor wiring is not connected to ground. t. See 1(c), (e), (f), (i). u. Realign cylinder. v. Stop using lifter and charge battery.
4. Spongy forks (sink a bit when loaded) or forks jerk when being raised.	<ol style="list-style-type: none"> w. Oil starvation. x. Air trapped in cylinder. 	<ol style="list-style-type: none"> w. See 1(c), (e), (f), (i). x. See “Air bleeding procedure” on p. 12.
5. Forks lower very slowly when loaded.	<ol style="list-style-type: none"> y. Lowering valve filter clogged. z. Pinched hose. aa. Debris caught in flow control valve. bb. Binding cylinder. cc. Debris in velocity fuse. 	<ol style="list-style-type: none"> y. Remove solenoid valve and clean filter. z. Correct as necessary. aa. Remove and clean flow control valve. Refer to “Hydraulic System Operation” section on p. 11. bb. Align cylinder. cc. Remove and clean velocity fuse.
6. Forks lower too quickly.	<ol style="list-style-type: none"> dd. Leaking hoses and/or fittings. 	<ol style="list-style-type: none"> dd. Correct or replace hoses/fittings to

	ee. Check valve stuck open. ff. Debris caught in flow control valve.	eliminate leaks. ee. Remove and clean check valve. ff. Remove flow control valve from valve manifold and clean. (See p. 11).
7. Forks rise but do not maintain position and slowly lower on their own.	gg. Lowering solenoid incorrectly wired or debris keeping it open. hh. Check valve stuck open. ii. Leaking hoses or fittings. jj. Cylinder packings worn or damaged.	gg. See 2(a). hh. Remove & clean check valve (see p. 11). ii. Correct or replace hoses/fittings to eliminate leaks. jj. Replace packings.
8. Forks rise but cannot be lowered.	kk. Incorrect lowering solenoid wiring. ll. Lowering solenoid is stuck. mm. Faulty lowering solenoid coil. nn. Object blocking downward travel. oo. Binding cylinder. pp. Velocity fuse activated. qq. Limit switch inoperative and mechanical stops engaged. If stops engaged, velocity fuse activated.	kk. Correct as necessary. Refer to wiring diagrams, FIGS. 3-7. ll. <i>Lightly</i> tap the solenoid coil body to seat it properly. DO NOT strike the coil firmly, because the internal stem might be permanently damaged. DO NOT remove the solenoid valve from the manifold, because the forks will lower dangerously quickly. mm. Remove and replace. nn. Raise forks and remove object blocking travel. Lower forks and confirm issue resolved. oo. See 2(e). pp. Repressurize the hydraulic system to unlock the velocity fuse (see "Velocity fuse operation" on p. 11). qq. Refer to "Velocity fuse operation" on p. 11.
9. Erratic operation.	rr. Low battery (DC units).	rr. Stop using lifter and charge battery.

Inspections & Maintenance:

NOTICE

Regular maintenance is essential to keep this product operating normally. Before beginning maintenance, unload the forks and lower them. Always use this product in accordance with the instructions in this manual and consistently with any training relevant to machines, devices, etc. used in conjunction with this product.

- Relieve hydraulic pressure whenever the unit is not in use by fully lowering the forks.
- Keep the product clean & dry. Lubricate moving parts at least once per month.
- ONLY use manufacturer-approved replacement parts. Vestil is not responsible for issues or malfunctions that result from the use of unapproved replacement parts.
- ONLY use ISO AW-32 hydraulic fluid or its equal in the hydraulic system. Do not use brake fluid or jack oils in the hydraulic system. If oil is needed, use an anti-wear hydraulic oil with a viscosity grade of 150 SUS at 100°F, (ISO 32 cSt @ 40°C), or Dexron transmission fluid.
- Contact the manufacturer for MSDS information.

After receiving the unit and before using it for the first time, create a written record that describes the appearance of the frame, forks, casters, pivot points and pivot point hardware, scissor legs, power unit, and cylinder. Cycle the forks all the way and all the way down. Record your observations about how the unit looks and sounds as the forks rise and lower. This written record establishes "normal condition". When conducting future inspections compare current observations with the written record to determine whether a component is in normal condition or requires repair or replacement. If issues are discovered during an inspection, restore the unit to normal condition before returning it to service.

Inspections:

(A) Before each use, examine the lifter for the following conditions:

- | | |
|--|---|
| 1. Frayed wires | 5. Loose hose fittings |
| 2. Oil leaks | 6. Bending, warping, or cracking forks or frame |
| 3. Normal caster function | 7. Unusual noise or binding while cycling the forks |
| 4. Pinched, kinked, or damaged hydraulic hoses | |

(B) At least once per month, perform the following inspections:

1. Check oil level in reservoir. Lower the forks and observe the oil level. Oil should be 1" to 1½" below the top of the tank. Add oil if necessary. Oil specifications = ISO AW-32 hydraulic fluid or equal.
2. Check for oil leaks. Correct or replace hoses/fittings to eliminate leaks.
3. Check water level in battery (DC units).

4. Check clevis pins and pivot points. Pins should be straight, securely held by retaining hardware, and not severely worn. Pivot points should not display severe wear. Lubricate pivot points.
5. Check hydraulic hoses for wear and damage. Replace any hose that has cracks or bulges.
6. Examine electrical cords and wires for damage. Repair or replace cords/wires as appropriate.
7. Check rollers for looseness and wear.
8. Inspect retaining rings of clevises and rollers.
9. Cycle the forks up and down. Listen for unusual noises. Refer to "Troubleshooting" section on pp. 12-13.
10. Check labeling (see "Labeling diagram" on p. 15). Make sure that all labels are in place, undamaged, and easily readable.
11. Clean lifter surfaces. Apply touch-up paint to areas where paint has been removed.

(C) At least once per year:

Change the hydraulic oil. Change the oil more frequently if it darkens, appears milky (water present), or becomes gritty. Only use ISO AW-32 hydraulic fluid or its equal.

Maintenance:

Implement a maintenance program to ensure the proper function and safety of the device. ANSI/ITSDF standard B56.10 describes some recommended maintenance procedures. The following steps should be utilized in conjunction with those recommendations.

Step 1: Tag the unit, "Out of Service."

Step 2: Conduct a "Before each use" inspection. If deformity, corrosion, rusting, or excessive wear of structural members is present, DO NOT use the pallet handler. Contact Vestil for instructions. If the carriage does not move smoothly or makes noise as it moves up or down the mast, apply a silicon wax or silicon spray to the inside of the mast frame.

Step 3: Remove any dirt or other matter from the forks and other surfaces.

Step 4: Perform all other necessary adjustments and/or repairs. DO NOT modify the lifter.

Step 5: Make a dated record of the repairs, adjustments and/or replacements.

Replacement Parts:

Our company uses carefully selected parts in our equipment. Whenever repairs are necessary, be certain that only manufacturer approved replacement parts are used. To order parts for your equipment, contact Customer Service at the factory. In any correspondence with the factory please include the Serial Number which is inscribed on the nameplate of the equipment. Use only the part numbers provided in this Owner's Manual. When ordering parts for AC power units, please be prepared with the motor phase and voltage of the equipment.

Onboard Battery Charger Operation (DC units only):

- ⚠WARNING** Working on lead-acid batteries is dangerous. Batteries contain sulfuric acid and produce explosive gases. A battery explosion could result in loss of eyesight or serious burns.
- DO NOT smoke near the battery or expose the battery to a spark or flame.
 - ONLY charge batteries in dry, well-ventilated locations.
 - DO NOT lay tools or metallic items on top of a battery. NEVER touch both terminals simultaneously! Remove personal items such as rings, bracelets, necklaces, and watches. A battery can produce enough voltage to weld jewelry to metal.
 - Always have plenty of fresh water and soap nearby in case contact with battery acid occurs.
 - Operating the battery with low voltage can cause premature motor contact failure.
 - The charger is equipped with an external ground wire (small green wire). During installation the charger must be grounded to the equipment which it is connected to. Be sure this wire is always connected to the chassis, frame, or other metallic surface considered to be ground.
 - Confirm that all battery connections are sound and clean. Remove all accumulated deposits on the terminals.
 - Replace defective electrical cords and wires immediately.
 - DO NOT use the charger if the flanged inlet is damaged.
 - DO NOT connect the charger to a damaged extension cord.

Every DC powered unit is equipped with an onboard battery charger with a flanged electrical inlet. The charger is current limited and will not exceed its rated output even if loads are placed on the battery while it is charging.

To charge the battery:

- 1.) Plug the charger into an 115V, 60 Hz receptacle by connecting the flanged inlet on the power unit (see to an extension cord. Plug the other end of the cord into a wall socket. Use a short, thick extension cord.
- 2.) When properly connected, the charge LED will indicate the status of charge current flowing to the battery.
 - If only the red LED is on, the charger is providing full output to the battery.
 - If both the red and green LED's are on, the charger is "topping off" the battery.
 - When only the green LED is on, the unit is providing a "float" (maintenance) charge.
 - DO NOT leave the charger on for long periods after the battery is fully charged.
- 3.) Unplug the charger before using the lifter. Failure to do so could cause damage to cords, receptacles, etc.

TROUBLESHOOTING--If the charger does not work:

- 1) Make sure all battery connections sound.
- 2) Confirm that the AC power source (e.g. wall socket) is supplying power.
- 3) Make sure that the fuse is intact (see p. 7). If not, replace it with a fuse having the same rating. The charger fuse will blow if it is connected in reverse polarity.
- 4) Determine battery condition. It may take some time before current begins to flow through a highly sulfated battery.

Labeling diagram:

Only use the dumper if it is labeled as diagrammed below. ALL labels must be readable and undamaged. Replace all damaged/unreadable labels.

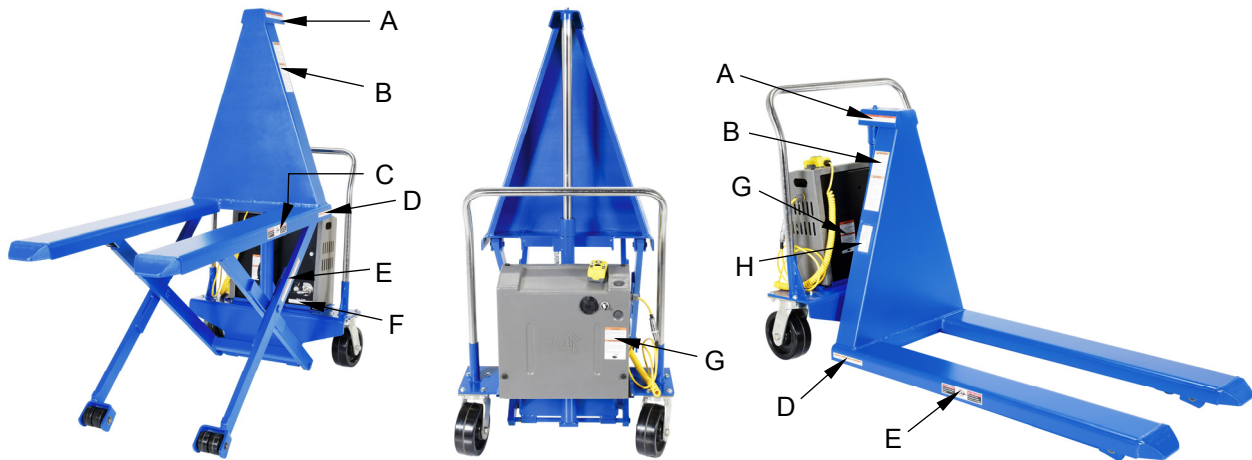

A: Label 658

⚠️ WARNING	⚠️ ADVERTENCIA	⚠️ AVERTISSEMENT
Do not operate or move with unstable loads DO NOT LOAD beyond rated capacity DISTRIBUTE LOAD EVENLY DO NOT sit or ride	No use a mueva con cargas inestables No cargue mas de la capacidad tasada DISTRIBUYA LA CARGA A NIVEL NO SE SIENTE o vaya en el carro	Ne pas utiliser avec une charge instable NE PAS CHARGER au-delà du débit nominale DISTRIBUER la charge régulièrement NE PAS VOUS ASSEoir OU VOUS PROMENER sur le chariot

B: Label 465

⚠️ WARNING

- DO NOT use if damaged.
- DO NOT place hands and/or feet under raised load or raised forks.
- DO NOT leave this product unattended UNLESS: immobilized, on even, level ground and forks are fully lowered.
- Keep load as low as possible when transporting.
- To instantly stop movement, lower load to the ground.

⚠️ AVISO

- No use si esta dañado
- No ponga las manos y/o los pies debajo de una carga elevada o de horquillas elevadas.
- No deje el producto desatendido A NO SER QUE: inmobilizado, a nivel, a nivel del suelo y las horquillas estén totalmente abajo.
- Mantenga la carga lo mas bajo posible cuando se este transportando.
- Para parar el movimiento instantaneamente, descienda la carga hasta el suelo.

C: Label 824

⚠️ DANGER

To avoid bodily injury, stand clear while in motion.

⚠️ PELIGRO

Para evitar daños, mantengase alejado cuando en movimiento

D: Label 212

⚠️ WARNING	⚠️ ADVERTENCIA	⚠️ AVERTISSEMENT
LOCK CASTER and/or FLOOR LOCK when loading and unloading	La RUEDECILLA de la CERRADURA y/o el PISO CIERRAN al cargar y descargar	LOCK CASTER et/ou SOL LOCK lors du chargement et de déchargement

E: Label 208

⚠️ WARNING	⚠️ ADVERTENCIA	⚠️ AVERTISSEMENT
KEEP CLEAR OF PINCH POINT	MANTENGASE ALEJADO DEL PUNTO DE CORTE	SE TENIR À DISTANCE DU POINT DE PINCEMENT

F: Label 206

ISO 32 / 150 SUS

HYDRAULIC OIL OR NON-SYNTHETIC TRANSMISSION FLUID
ACEITE HIDRAULICO O LIQUIDOS DE TRANSMISION NO SINTETICOS
HUILE OU LIQUIDE HYDRAULIQUE NON-SYNTHÉTIQUE

VESTIL MANUFACTURING CORPORATION • Phone (260) 665-7586 • www.vestil.com

G: Label 295

⚠️ WARNING

Enclosed battery contains hazardous chemicals.
DO NOT handle enclosed battery UNLESS wearing eye protection and other appropriate personal protective equipment.
DO NOT directly contact skin with battery.
DO NOT expose to sparks or extreme heat; battery contains explosive gases.

⚠️ ADVERTENCIA

La batería incluida contiene materiales peligrosos.
NO use la batería incluida A NO SER que lleve protección de ojos y otros equipos de protección apropiados para el personal.
NO tenga contacto directo en la piel con la batería.
NO exponga a destellos o a calor excesivo, la batería contiene gases explosivos.

H: Label 287 – Product data label.

MODEL/MODÉLO/MODÈLE _____

STATIC CAPACITY (evenly distributed) _____ lbs.

LA CAPACIDAD CONSTANTE (distribuida uniformemente) _____ kgs.

CAPACITÉ STATIQUE (distribuée régulièrement) _____ kgs.

SERIAL/SERIE/SÉRIE _____

287 REV 0812

LIMITED WARRANTY

Vestil Manufacturing Corporation (“Vestil”) warrants product to be free of defects in material and workmanship during the warranty period. *Our warranty obligation is to provide a replacement for a defective original part if the part is covered by the warranty, after we receive a proper request from the warrantee (you) for warranty service.*

Who may request service?

Only a warrantee may request service. *You are a warrantee if* you purchased the product from Vestil or from an authorized distributor AND Vestil has been fully paid.

What is an “original part”?

An original part is a part used to make the product as shipped to the warrantee.

What is a “proper request”?

A request for warranty service is proper if Vestil receives: 1) a photocopy of the Customer Invoice that displays the shipping date; AND 2) a written request for warranty service including your name and phone number. Send requests by any of the following methods:

<u>Mail</u>	<u>Fax</u>	<u>Email</u>
Vestil Manufacturing Corporation 2999 North Wayne Street, PO Box 507 Angola, IN 46703	(260) 665-1339 <u>Phone</u> (260) 665-7586	sales@vestil.com

In the written request, list the parts believed to be defective and include the address where replacements should be delivered.

What is covered under the warranty?

After Vestil receives your request for warranty service, an authorized representative will contact you to determine whether your claim is covered by the warranty. Before providing warranty service, Vestil may require you to send the entire product, or just the defective part or parts, to its facility in Angola, IN. The warranty covers defects in the following original dynamic components: motors, hydraulic pumps, electronic controllers, switches and cylinders. It also covers defects in original parts that wear under normal usage conditions (“wearing parts”), such as bearings, hoses, wheels, seals, brushes, and batteries.

How long is the warranty period?

The warranty period for original dynamic components is 1 year. For wearing parts, the warranty period is 90 days. The warranty periods begin on the date when Vestil ships the product to the warrantee. If the product was purchased from an authorized distributor, the periods begin when the distributor ships the product. Vestil may, at its sole discretion, extend the warranty periods for products shipped from authorized distributors by *up to* 30 days to account for shipping time.

If a defective part is covered by the warranty, what will Vestil do to correct the problem?

Vestil will provide an appropriate replacement for any *covered* part. An authorized representative of Vestil will contact you to discuss your claim.

What is not covered by the warranty?

1. Labor;
2. Freight;
3. Occurrence of any of the following, which automatically voids the warranty:
 - Product misuse;
 - Negligent operation or repair;
 - Corrosion or use in corrosive conditions;
 - Inadequate or improper maintenance;
 - Damage sustained during shipping;
 - Accidents involving the product;
 - Unauthorized modifications: DO NOT modify the product IN ANY WAY without first receiving written authorization from Vestil. Modification(s) might make the product unsafe to use or might cause excessive and/or abnormal wear.

Do any other warranties apply to the product?

Vestil Manufacturing Corp. makes no other express warranties. All implied warranties are disclaimed to the extent allowed by law. Any implied warranty not disclaimed is limited in scope to the terms of this Limited Warranty.

