

VESTIL MANUFACTURING CORP.  
2999 N. Wayne St., Angola, IN 46703  
Ph: 260-665-7586 · Fax: 260-665-1339  
E-mail: sales@vestil.com · Website: www.vestil.com

# OWNER'S MANUAL

## MODELS EHLT (1-4K) & PST (1-3K), 43"-55" RAISED HEIGHTS

Serial number \_\_\_\_\_

Installation Instructions .....	2	Electrical & Hydraulic Diagrams .....	10-12
Operation Instructions .....	3-4	Power Unit's Operation .....	13
Routine Maintenance & Safety Checks .....	5	DC Power Unit, Exploded Parts .....	14-15
Structural, Exploded Parts (EHLT) .....	6	AC Power Unit, Exploded Parts .....	16-17
Structural, Exploded Parts (PST) .....	7	Troubleshooting .....	18
Structural Bill of Materials (EHLT & PST) .....	8	Safety Label Identification .....	19
Motor & Transformer Connections .....	9	Warranty .....	20

### IMPORTANT NOTES, WARNINGS AND SAFETY INSTRUCTIONS

Ensure that all employees understand and follow the following.

- ☞ Failure to read and understand this owner's manual before using or servicing the scissor lift constitutes a misuse of the product. All persons who will install, use, or care for this product must be familiar with this information.
- Non-portable units must be securely anchored to a level concrete surface.
- The scissor lift is intended for use only on level, concrete surfaces.
- The lift's load must be centered and evenly distributed on the platform.
- The platform should be lowered before transporting any loads (PST only).
- The load must be removed and the platform fully lowered before any work is performed on the scissor lift.
- Do not use the scissor lift if any damage or unusual noise is observed.
- Always watch the load carefully when the scissor lift is in operation.
- Ensure that all information/ safety/warning labels remain in place and are legible. See the labels page.
- For battery-powered units, review the Battery Info page.
- Do not use brake fluid or jack oils in the hydraulic system. If oil is needed, use an anti-wear hydraulic oil with a viscosity grade of 150 SUS at 100°F, (ISO 32 cSt @ 40°C), or Dexron transmission fluid.
- Contact the manufacturer for any needed MSDS information.
- ◆ Do not perform any modifications to the scissor lift without the manufacturer's approval. Failure to receive authorization for changes to the equipment could void the warranty.
- ◆ Maintenance and repairs are to be done only by personnel qualified to perform the required work. Consideration will not be given for warranty repair charges without prior written authorization by the manufacturer.

### WHEN ORDERING

#### REPLACEMENT PARTS:

We take pride in using quality parts on the equipment we manufacture. We are not responsible for equipment problems resulting from the use of unapproved replacement parts.

To order replacement or spare parts for this equipment, contact the factory.

In any communication with the factory please be prepared to provide the machine's serial number, which is indicated on the machine dataplate.

### RECEIVING INSTRUCTIONS

It is possible that this product could incur damage during transit.

Inspect the unit closely when it arrives. *If you see evidence of damage or rough handling to either the packaging or to the product when it is being unloaded, immediately make a note of it on the Bill Of Lading!*

It is important that you remove the product's packaging upon its arrival to ensure that there is no concealed damage or to enable a timely claim with the carrier for freight damage.

Also verify that the product and its specifications are as ordered.

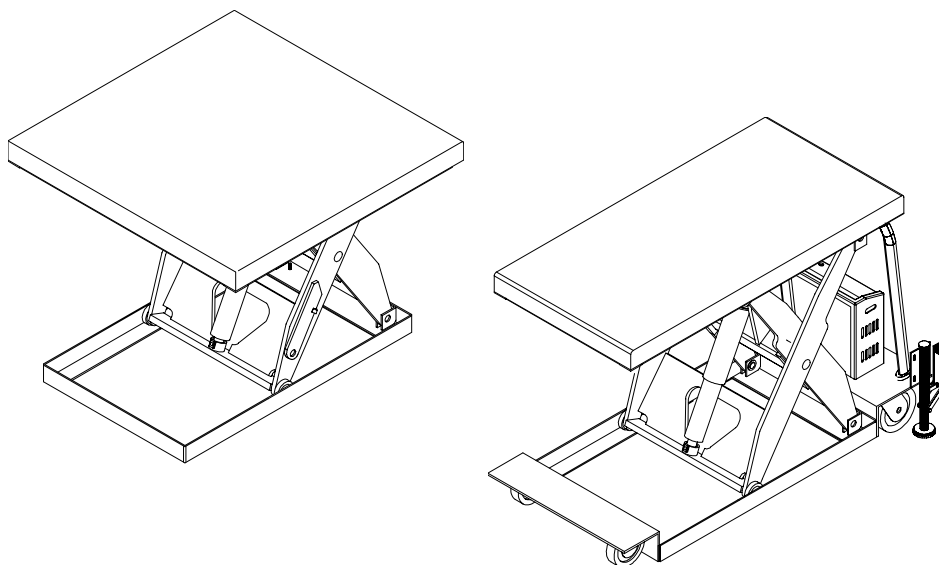

## INSTALLATION INSTRUCTIONS – EHLT (1-4K)

*Review this entire page before installing the scissor lift.*

*Consult the factory in the event there are any questions or problems at the time of installation, or for information regarding optional features not covered by the owner's manual.*

*The scissor lift must be removed from the shipping wood and securely anchored to a concrete surface before use!*

- Modifications or additions to the scissor lift without prior manufacturer's authorization may void the lift's warranty (see ANSI MH29.1-2003, Safety Requirements for Industrial Scissor Lifts, Section 12.6). The addition of ancillary equipment to the lift may necessitate that its load capacity be reduced.
- The installation must be made so that it complies with all the regulations applicable to the machine and its location. The end-user must verify that the supplied equipment is installed so it will be suited to the environment in which it will be used.
- Installation must be performed by suitably trained personnel with access to the appropriate equipment. The electrical aspects of the installation should be performed by an electrician.

**Note:** If the unit is to be placed into a pit, you will need to first determine how the required electrical (and possibly hydraulic) connections will be made once the unit is in place.

-----  
For a typical installation of a standard scissor lift you will need the following:

1. A fork truck or hoisting means to unload the scissor lift from the freight truck and set it into place.
2. A smooth, level, and adequately strong concrete surface on which to mount the scissor lift.
3. Concrete anchors, a masonry drill, a masonry bit, hand tools, grout, and steel shims. Consult the building's architect or facility engineer to determine the best size and type of hardware with which to anchor the machine to the floor.
4. An appropriate power supply circuit and electrical disconnect matching the motor voltage and current requirements. Refer to the machine's dataplate, to the labels on the control enclosure, and to the electrical section in this manual for more information. The end-user is responsible for supplying the branch circuit's required ground fault and short-circuit protection. (Motor overload protection is provided by a thermostat built into the motor.)

-----  
To install a standard scissor lift:

1. The scissor lift must be lowered and fully supported under its frame when moved. Move the scissor lift into place with straps or forks that span underneath the entire width or length of the frame. Use care to avoid damage the electrical or hydraulic components inside the scissor lift.
2. Temporarily connect the power supply to the pigtail cord supplied with the scissor lift, and raise the platform so the lift's safety maintenance props can be installed between the legset's frame rollers and the end of the lift's frame. Lower the legset until the rollers rest on the props.
  - If the platform must be raised without first having the proper power supply connected, raise the platform at the end of the table through which the power supply cord enters the frame. Use caution to avoid damage to the perimeter pinch point (toe) guard! Use a hoist with straps or chain rigging, or insert a lift truck's forks, at the hinged end of the platform. *Take care to not damage the hanging aluminum toe guard.* The frame must be held down at the ends of the shipping 4 x 4's on the hinged end of the lift while the platform is raised.
3. Anchor the frame to the floor through the four 9/16" holes located in the frame.
4. Shim and/or grout under the full length of the frame sides.
5. Make permanent connection to the power supply, using an appropriate wiring method.
6. Operate the scissor lift through several full raise and lower cycles. Verify that the upper travel limit switch (mounted near the left-side frame hinge) and the toe guard switches (around the perimeter of the platform) function properly.
7. Check the hydraulic oil level. It should be filled to within 1" to 1½" of the reservoir's fill hole. If oil is needed, use an anti-wear hydraulic oil with a viscosity grade of 150 SUS at 100°F (ISO 32 at 40°C) or a non-synthetic automatic transmission fluid.
8. Clean up any debris or spilled oil, and verify that all of the information/safety/warning labels are in good condition.

## OPERATION INSTRUCTIONS – EHLT (1-4K) & PST (1-3K)

- Consult ANSI MH29, Section 12 for the owner's/ user's responsibilities regarding the operation, care, and maintenance of this machine.
- Ensure that all employees involved in the operation of this scissor lift understand and follow these instructions!

The standard model scissor lift is suitable for use indoors in most non-classified industrial locations and many commercial locations. It is intended to be used to lift and transport (PST only) stable, evenly-distributed, non-hazardous materials loads having a size or footprint approximately the same size as the platform.

### Loading:

The load rating, in pounds, is shown on the machine dataplate located on the right corner of the hinged end of the platform. It indicates the net capacity of the scissor lift with a static load that is centered and evenly distributed on the platform.

When not fully lowered, the scissor lift's maximum single axle load is 50% of the rated capacity for side loading, and 75% for end loading. (The hydraulic hose and power cord are at one of the platform's ends.)

*Warning:* Do not exceed the scissor lift's load ratings. Injury to personnel or permanent damage to the lift could result from exceeding the listed capacity.

*Warning:* The platform's rollers are not captured. Therefore, do not overhang any load at the hinged end of the platform - that could cause the roller end of the platform to tip up and dump the load. For applications involving side or end edge loading, consult the factory.

*Note:* The addition of any ancillary equipment to the scissor lift by third parties must be taken into account when determining the maximum working load to be placed on the platform.

### Operation:

Inspect the perimeter pinch point guards' operation daily.

*Warning:* Keep all personnel clear of the machine when it is in operation. Be certain no part of any person or object is under any part of the platform before lowering the unit.

*Caution:* Always carefully watch the area around the platform and any load on the platform when it is in operation.

The standard model EHLT scissor lift table is furnished with an internally-mounted power unit and a constant-pressure (dead-man style) handheld pushbutton control.

- Pressing the "UP" pushbutton will turn on the power unit to raise the platform. The platform will raise only while the pushbutton is pressed. Upon releasing the pushbutton, the platform will stop and hold its position. When the platform reaches its maximum raised height, an upper travel limit switch will stop the lift from raising further.
- Pressing the "DOWN" pushbutton will energize the lowering valve to allow the platform to descend by gravity (the motor does not run). Again, releasing the pushbutton will stop the platform movement, and the unit will hold its position. In the event of an obstruction under the edge of the platform, the perimeter pinch point guard will raise to engage a switch and thereby de-energize the lowering valve.

*Caution:* Never use the scissor lift if any damage or unusual noise is observed, if it is in need of repairs, or if it seems to be malfunctioning. Notify your supervisor or maintenance personnel if you notice anything out of the ordinary.

Units with external, covered, modular power units also have pushbuttons and a key switch in the power unit cover. The key switch must be turned to the "ON" position for any of the controls to operate.

Standard model PST's are DC-powered and equipped with a covered, modular power unit having an on-board battery charger, and the 2-button handheld pushbutton control. It's operation is the same as the model EHLT.

*Warning:* before raising the platform from its lowered position, the floor lock must be positively engaged with the floor. Also, the platform should be fully lowered when a load is being transported. Failure to do so could result in injury to personnel or damage to product or equipment due to the lift and its load becoming unstable during transport.

*Note:* attempting to raise the lift when the battery charge is low will cause the motor relay protection circuit to prevent the motor's operation. Adequate battery voltage is indicated by a green LED on the motor relay. See the next page for more notes regarding operation of battery-powered units.

PST's equipped with the optional two-speed foot pump are operated by repeatedly stepping on the foot pump treadle to raise the platform, and by stepping on the smaller release pedal on the left corner of the foot pump body to lower the platform. The pump's output (and therefore the lifting rate) can be changed by means of a slider at the top of the foot pump. The low-speed output must be used when the platform is loaded.

Ensure that all information/safety/warning labels stay in place and are legible. Refer to the labels page in this manual.

## ADDITIONAL INSTRUCTIONS FOR BATTERY-POWERED UNITS

*Note: If this product has the 24V powered traction-drive option, consult that option's information for more specific details regarding the batteries and battery charger.*

### **Warning!**

- ! Working with or near lead acid batteries is dangerous. Batteries contain sulfuric acid and produce explosive gases. A battery explosion could result in loss of eyesight or serious burns.
- ! Do not smoke or allow a spark or flame near batteries. Charge batteries in locations that are clean, dry, and well ventilated. Do not lay tools or anything metallic on top of any battery. All repairs to a battery must be made by experienced and qualified personnel.
- ! When working with batteries, remove personal items such as rings, bracelets, necklaces, and watches. Batteries can produce enough energy to weld jewelry to metal, causing a severe burn.
- ! Always have fresh water and soap nearby in case battery acid contacts skin, clothing, or eyes.
- ! Operating the battery with a low battery voltage can cause premature motor contact failure.
- ! Do not expose the lift or the charger to rain or adverse conditions.
- ! Replace defective cords or wires immediately.
- ! Check the battery's water level frequently.

### **Battery Charger Operating Instructions**

Never operate the charger with either of the cables coiled. Operating a battery charger with the cord either coiled or wrapped around itself could cause the cord to overheat, melt, and cause a short-circuit or a fire.

Connection: the ribbed wire of the charger's output cord must be connected to the battery's negative (-) terminal. The non-ribbed wire (with words printed on it) must be connected to the battery's positive (+) terminal.

When properly connected, the charger will indicate the status of its output:

Flashing green LED - the charger is not seeing a good connection to the battery.

Solid yellow LED - the charger is providing charging current to the battery.

Solid green LED - the charger is maintaining a fully charged battery.

Plug a 115V, 3-prong extension cord into a standard 115V receptacle. Keep the cord as short as possible.

*Caution:* Remember to unplug the charger before moving the equipment. Failure to do so could cause damage to cords, receptacles, and other equipment.

The battery charger can be left connected to the battery indefinitely without risk of harming the battery.

### **Troubleshooting:**

If the unit does not operate, check all of the wiring connections to make sure they're both mechanically and electrically sound - specifically at the battery, the motor, and at any location a wire is connected to the chassis. Also, make sure the quick-connect plug on the end of the pendant control cord is plugged in correctly (if applicable).

A fully charged lead acid battery in good condition at room temperature should read 12.65 volts. At 11.9 volts it is considered to be fully discharged and in need of charging. When checking battery voltage, wait at least 1/2 hour after the charger has been turned off before checking the battery's voltage.

If the batteries don't seem to be taking a charge, check the charger's 115V supply circuit and the charger's output with a voltmeter. If all check okay, confirm the battery's state of charge using a hydrometer or a voltmeter.

## **ROUTINE MAINTENANCE & SAFETY CHECKS – EHLT (1-4K) & PST (1-3K)**

- *Warning: Care should be taken to identify all potential hazards and comply with applicable safety procedures before beginning work.*
- *Warning: Install the maintenance props before beginning any inspections or work on the unit. See below.*
- *Only qualified individuals trained to understand mechanical devices and their related electrical and hydraulic circuits, and the hazards associated with them, should attempt troubleshooting and repair of this equipment.*

### **Maintenance Prop Installation:**

Always install the maintenance prop or fully lower the platform before beginning work on the scissor lift table. A maintenance prop is located on the outside of each of the outer legs of the legset.

*To install the safety maintenance props:*

- Raise the platform to its full raised height.
- Rotate each prop forward so that its free end drops down onto the lift table's frame.
- Lower the platform until the maintenance props rest against the end member of the frame.

(A) Inspect daily for:

- 1.) Frayed wires.
- 2.) Oil leaks.
- 3.) Pinched or chafed hoses.
- 4.) Damage to the casters. (Portable units.)
- 5.) Damage or structural deformation to the structural members, the cylinder brackets, etc.
- 6.) Unusual noise or binding, or evidence thereof.
- 7.) Proper functioning of all limit switches, including those on the perimeter pinch point guard (if applicable).

(B) Inspect monthly for:

- 1.) The oil level. Oil should be 1" to 1½" below the reservoir's fill hole with the platform in the fully lowered position. See below for the hydraulic oil specification.
- 2.) Worn or damaged hydraulic hoses and electrical wires.
- 3.) Pivot point wear.
- 4.) Rollers' looseness and wear.
- 5.) Integrity of the retaining hardware on all rollers and on all pivot point pins.
- 6.) The integrity of the frame anchor bolts, and for cracks in the concrete around them. (Non-portable units.)
- 7.) Looseness, wear, or damage to the casters' bearings, mounting hardware, or surface material. (Portable units.)
- 8.) Proper functioning of any hand- or foot-operated mechanisms.
- 9.) Proper water level in the battery (DC units.)
- 10.) Unusual noises or movement during operation.
- 11.) All the information/safety/warning labels being in place and in good condition.
- 12.) The need to clean off dirt and debris.

(C) Yearly inspection

The oil should be changed if the oil darkens, becomes gritty, or turns a milky color (indicating the presence of water). Replace with an anti-wear hydraulic oil with a viscosity grade of 150 SUS at 100°F, (ISO 32 at 40°C). Ex: AW 32 or HO 150 hydraulic oil, or a non-synthetic transmission fluid. You may use a synthetic transmission fluid if you flush the system with the synthetic fluid before filling the reservoir.

**EXPLODED PARTS VIEW -- EHLT (1-4K)**

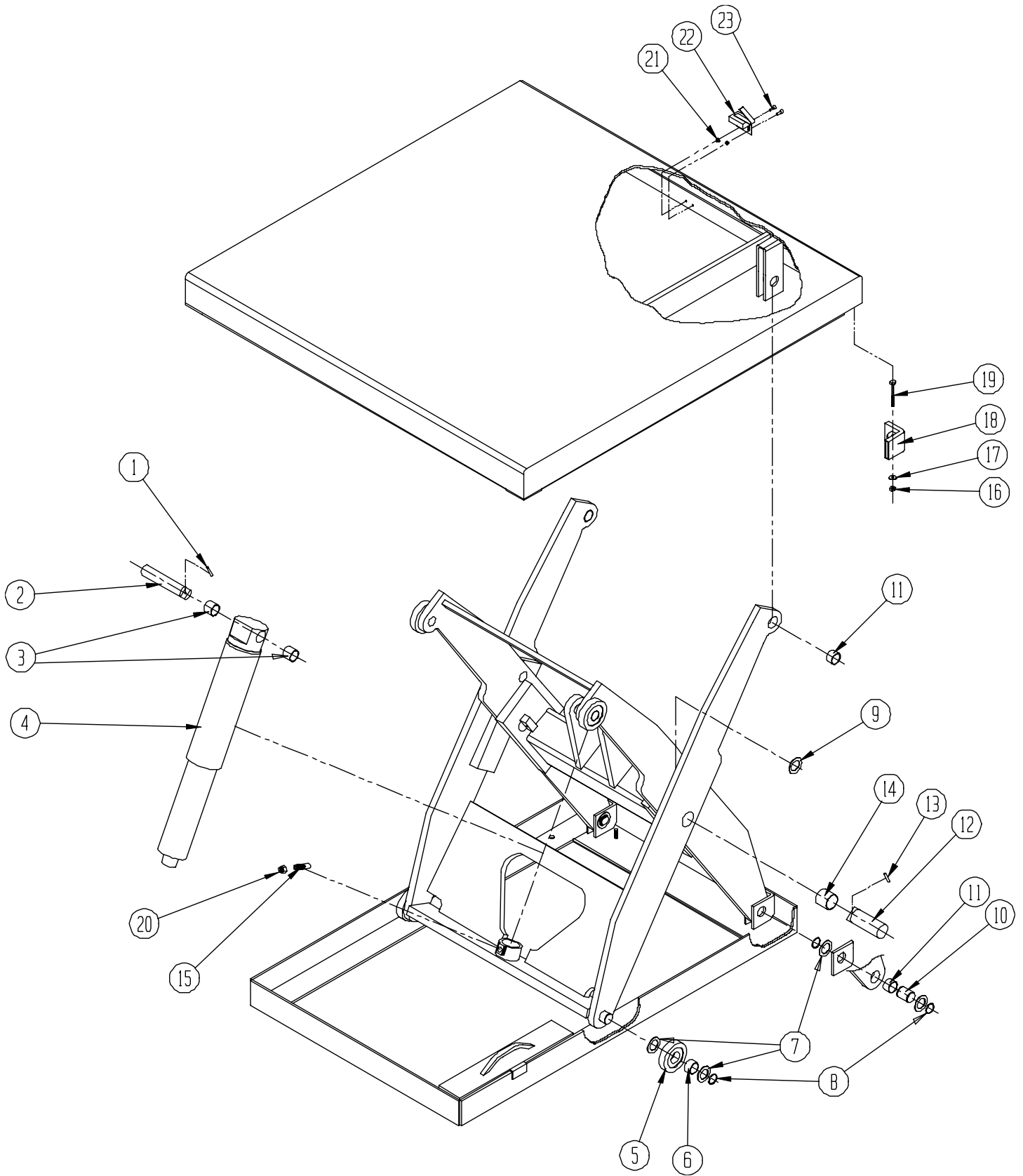

**EXPLODED PARTS VIEW -- PST (1-3K)**

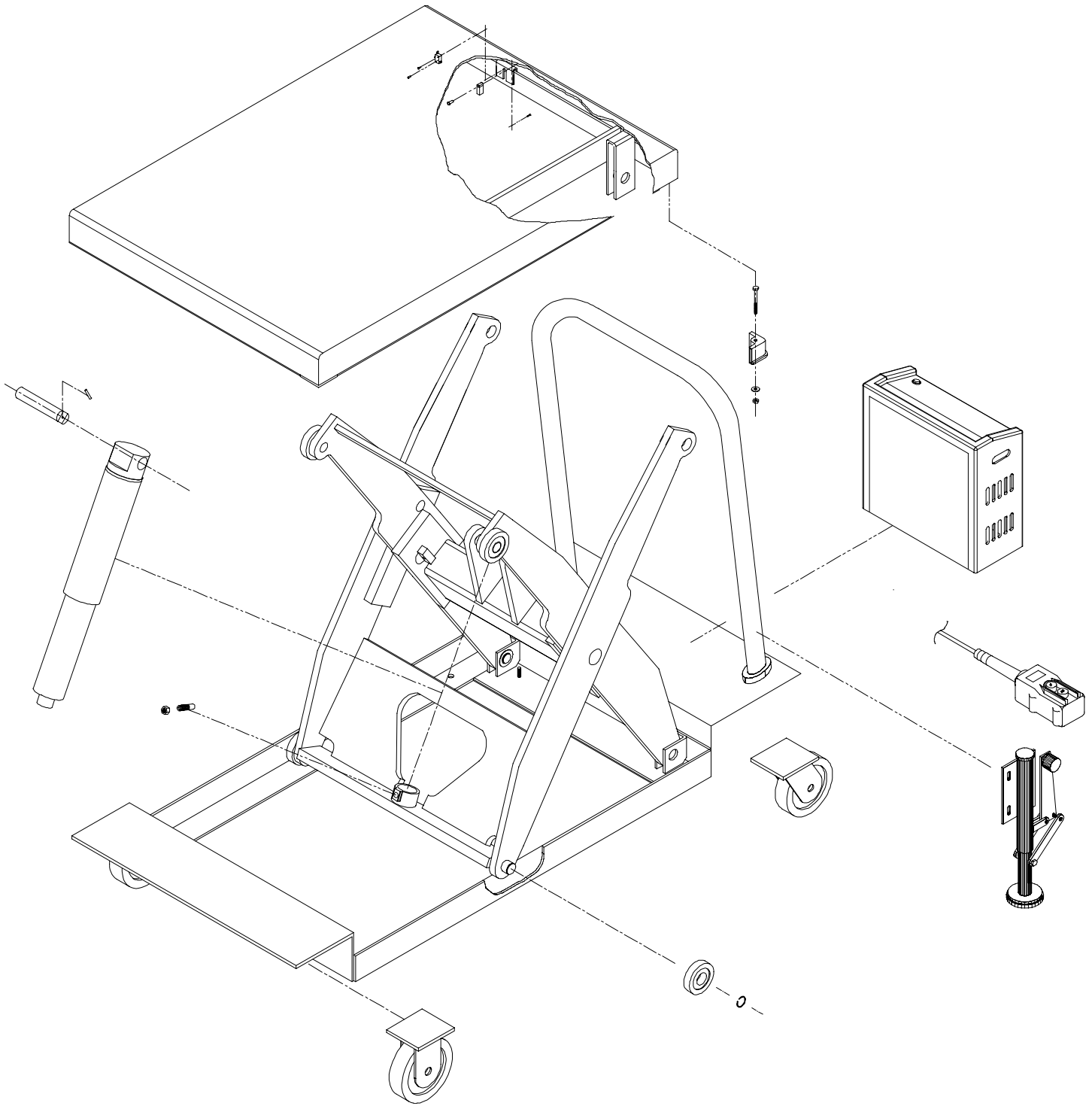

**STRUCTURAL BILL OF MATERIALS -- EHLT (1-4K) & PST (1-3K)**

<b>Item #:</b>	<b>Description</b>	<b>Part number</b>	<b>Qty.</b>
1	Pin, spring, $\frac{3}{16}$ " $\varnothing$ x $1\frac{1}{8}$ " long	A/L	1 or 2
2	Pin, pivot, $1\frac{1}{8}$ " $\varnothing$ x 8.65" OAL	24-112-005	1 or 2
3	Bearing, sleeve, $1\frac{1}{8}$ " $\varnothing$ x $\frac{3}{4}$ " long	01-111-002	2 or 4
4	Cylinder, hydraulic, 2" $\varnothing$ x 10" stroke	99-021-903	1
	Cylinder, hydraulic, 2 $\frac{1}{2}$ " $\varnothing$ x 10" stroke	99-021-906	1 or 2
	Cylinder, hydraulic, 3" $\varnothing$ x 10" stroke	99-021-901	1 or 2
5	Roller, $3\frac{1}{4}$ " $\varnothing$ x $\frac{3}{4}$ " wide	01-027-001	4
6	Bearing, sleeve, $1\frac{1}{8}$ " ID x $\frac{5}{8}$ " long	01-111-001	4
7	Bushing, machinery, .06" thick x $1\frac{1}{8}$ " ID	01-115-001	16
8	Snap ring, external, $1\frac{1}{8}$ " ID	A/L	12
9	Bushing, machinery, .06" thick x $1\frac{1}{2}$ " ID	01-115-003	4
10	Pin, hinge, $1\frac{1}{8}$ " $\varnothing$ x 1.81" OAL	01-112-004	4
11	Bearing, sleeve, $1\frac{1}{8}$ " ID x $\frac{3}{4}$ " long	01-111-002	4
12	Pin, axle, $1\frac{1}{2}$ " $\varnothing$ x 4.53" OAL	01-112-019	2
13	Bolt, shoulder, $\frac{3}{8}$ "-18 UNC x $1\frac{1}{2}$ " long	A/L	2
14	Bushing, sleeve, $1\frac{1}{2}$ " ID x $1\frac{1}{2}$ " long	01-111-003	2
15	Bolt, cylinder retaining, $\frac{1}{2}$ "-13 UNC x 2" OAL	01-118-001	1 or 2
16	Nut, hex, nylock, $\frac{1}{4}$ "-20 UNC	A/L	4
17	Washer, flat, $\frac{1}{4}$ " ID	A/L	4
18	Support, toe guard, corner	01-015-009	4
19	Bolt, hex head, $\frac{1}{4}$ "-20 UNC x $2\frac{1}{2}$ " long	A/L	4
20	Nut, jamb, hex, $\frac{1}{2}$ "-13 UNC	A/L	1 or 2
21	Screw, FSHSC, #8-32 UNC x $\frac{1}{2}$ " long	A/L	2
22	Actuator, toe guard	01-015-008	2
23	Bolt, sex, #8-32 UNC x $\frac{3}{8}$ " deep	01-145-010	2
24	Switch, micro, normally-closed	01-022-022	2
25	Screw, BHSC, #4-40 UNC x $\frac{1}{2}$ " long	A/L	4
26	Extrusion, aluminum, perimeter pinch point (length varies)	01-015-912	4

**ONLY ON PST (1-3K), NOT SHOWN ON STRUCTURAL LIST**

<b>Item #:</b>	<b>Description</b>	<b>Part number</b>	<b>Qty.</b>
1	Caster, phenolic, swivel, 2" wide x 8" $\varnothing$	PH-8/2-S	2
2	Caster, phenolic, rigid, 2" wide x 8" $\varnothing$	PH-8/2-R	2
3	Floor lock, side-mounted	FL-LK-SMR	1
4	Power unit, modular	MPU-(AC or DC)-(voltage)	1
5	Control, pendant, 2-button	See exploded parts list	1



## MOTOR & TRANSFORMER CONNECTION DIAGRAMS

**CAUTION!** *If the motor voltage is changed, the wire on the control transformer's primary wire has to be changed to match the new motor voltage also.*

MOTOR LEAD CONNECTION DIAGRAM FOR ALL  
.5HP, .75HP AND 3HP SINGLE-PHASE MOTORS AND FOR  
ALL 2HP, 5.5HP, AND 6.5HP THREE-PHASE MOTORS

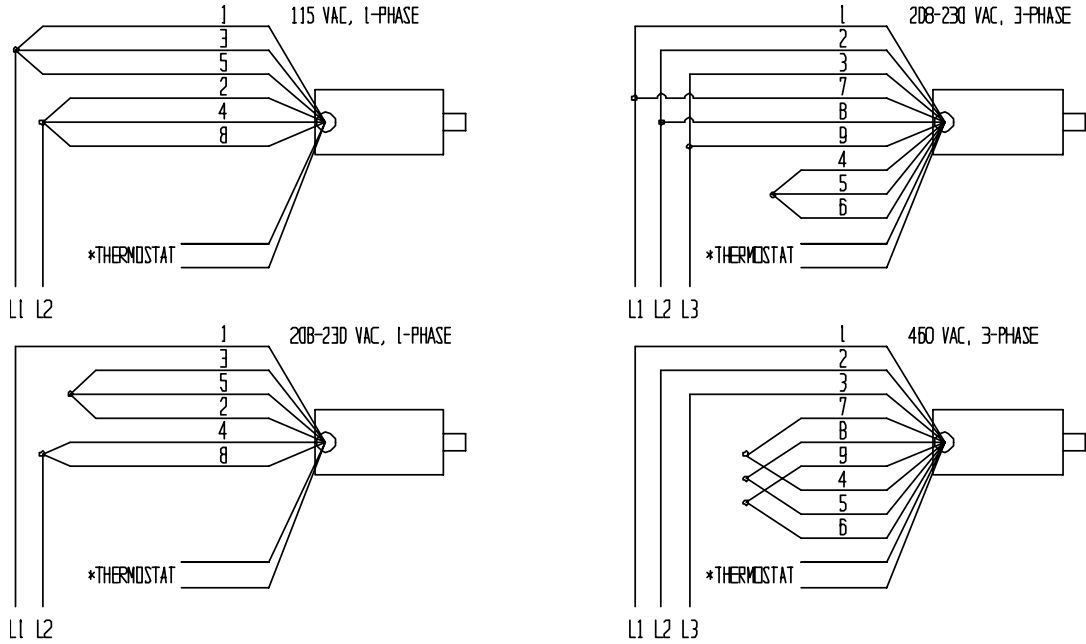

\* The two thermostat leads go to: 1) the grounded side of the transformer secondary, and; 2) the motor relay coil, in either order.



**BE SURE ALL POWER IS OFF BEFORE ATTEMPTING TO WORK ON THIS EQUIPMENT!**

**CAUTION: SERVICE WORK SHOULD BE PERFORMED ONLY BY TRAINED & QUALIFIED PERSONNEL.**

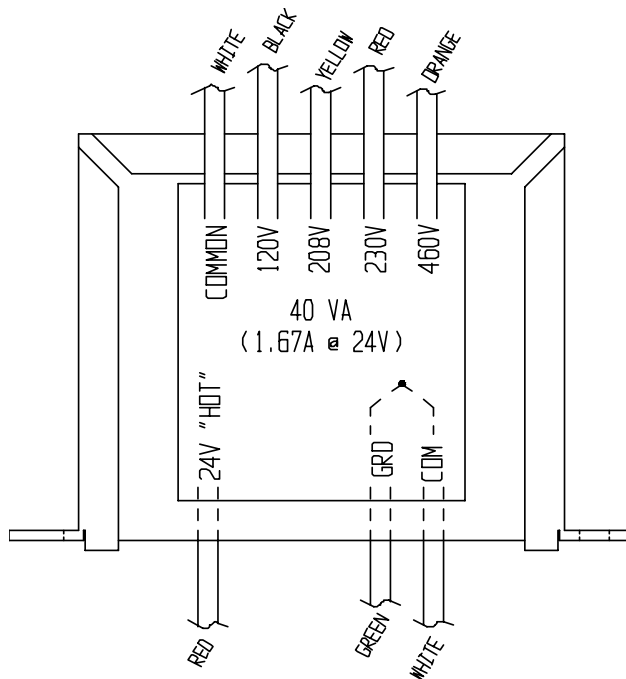

### ELECTRICAL DIAGRAM -- EHLT (1-4K)

- o Warning: Care should be taken to identify all potential hazards and comply with applicable safety procedures before beginning work. Ensure that all system pressure and power have been removed before attempting to work on the electrical or hydraulic systems.
- o *Warning:* The load must be removed, and the platform either positively and adequately supported or fully lowered, before any work is performed on the scissor lift.
- o *Only qualified individuals trained to understand mechanical devices and their associated electrical and hydraulic circuits, as well as the hazards associated with them, should attempt troubleshooting and repair of this equipment.*

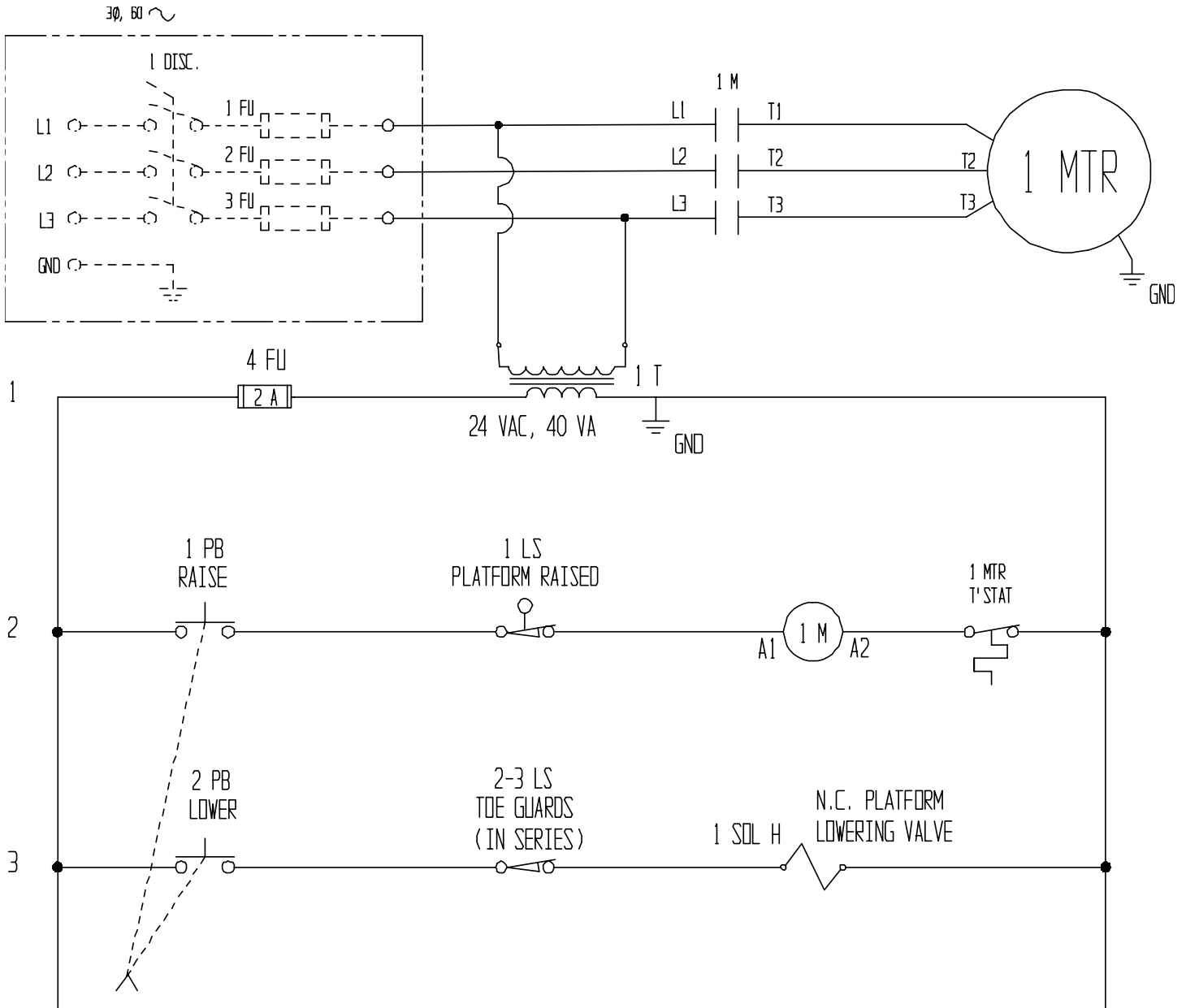

### ELECTRICAL DIAGRAMS -- PST (1-3K)

- Warning: Care should be taken to identify all potential hazards and comply with applicable safety procedures before beginning work. Ensure that all system pressure and power have been removed before attempting to work on the electrical or hydraulic systems.
- *Warning:* The load must be removed, and the platform either positively and adequately supported or fully lowered, before any work is performed on the scissor lift.
- *Only qualified individuals trained to understand mechanical devices and their associated electrical and hydraulic circuits, as well as the hazards associated with them, should attempt troubleshooting and repair of this equipment.*

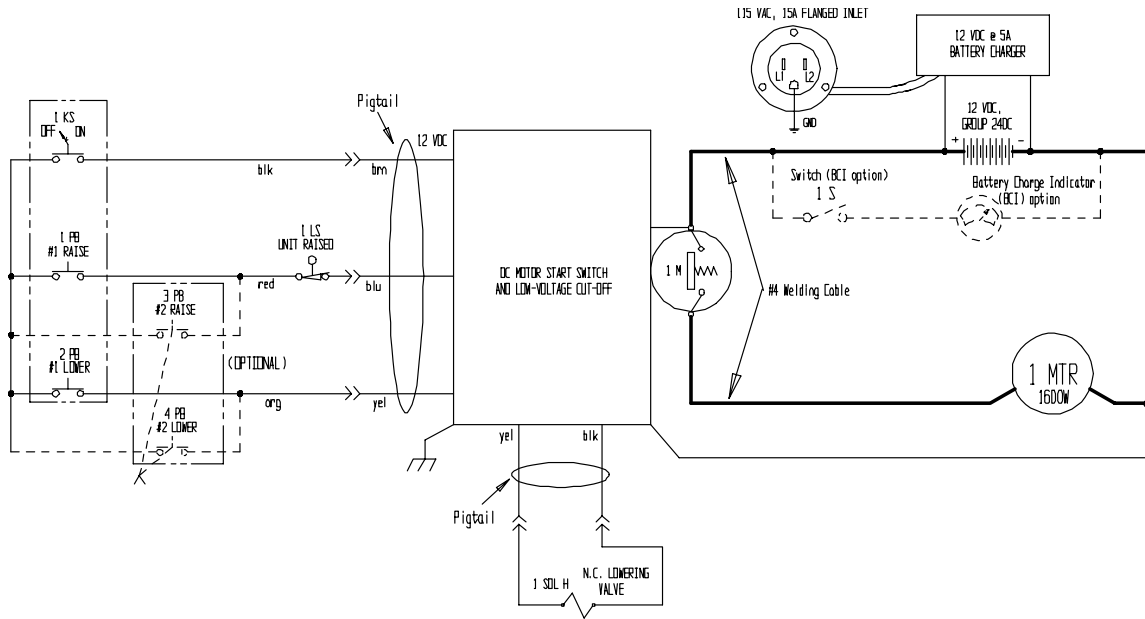

OVERCURRENT & SHORT-CIRCUIT PROTECTION, AND DISCONNECT, ARE TO BE PROVIDED BY THE END-USER PER THE NEC (NFPA 70) AND LOCAL CODES.

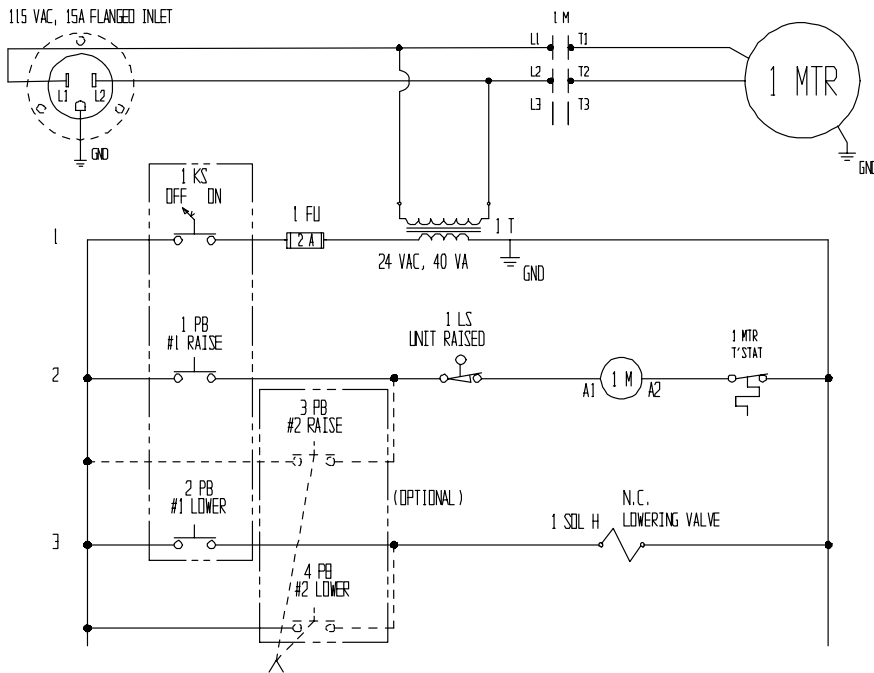

**⚡ BE SURE ALL POWER IS OFF BEFORE ATTEMPTING TO WORK ON THIS EQUIPMENT!**  
**CAUTION: SERVICE WORK SHOULD BE PERFORMED ONLY BY TRAINED & QUALIFIED PERSONNEL**

**HYDRAULIC DIAGRAMS – EHLT (1-4K) & PST (1-3K)**

- *Warning: Care should be taken to identify all potential hazards and comply with applicable safety procedures before beginning work. Remove the load, rest the legset on the maintenance props or fully lower the platform to the floor, and ensure that all system pressure and power have been removed before attempting to work on the electrical or hydraulic systems.*
- *Remove the load, raise the lift and install the maintenance props before beginning any inspections or work on the unit.*
- *Only qualified individuals trained to understand mechanical devices, their associated electrical and hydraulic circuits, and their associated hazards, should attempt troubleshooting and repair of this equipment.*
- *Caution: Do not use brake fluid or jack oils in the hydraulic system. If oil is needed, use an anti-wear hydraulic oil with a viscosity of 150 SUS at 100°F (ISO 32 @ 40°C), or non-synthetic transmission fluid.*

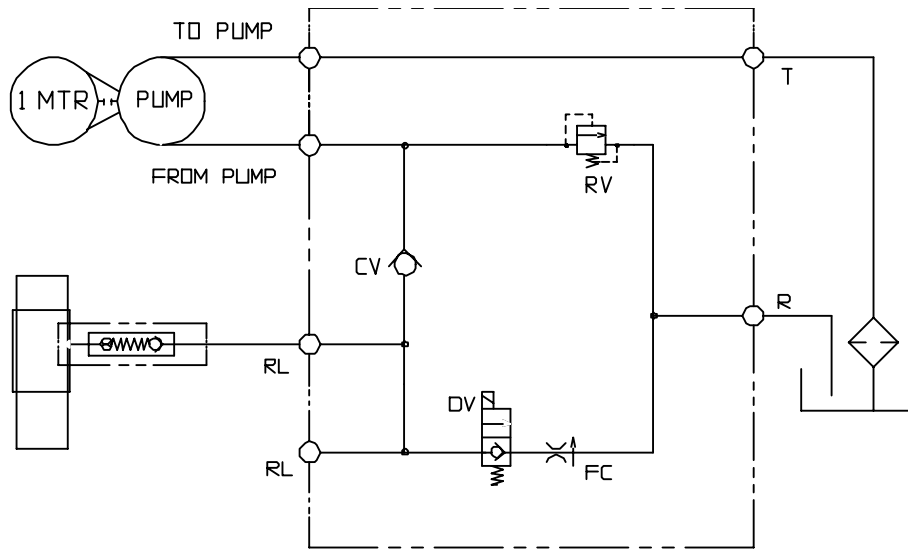

GEAR PUMP HYDRAULIC LOGIC DIAGRAM

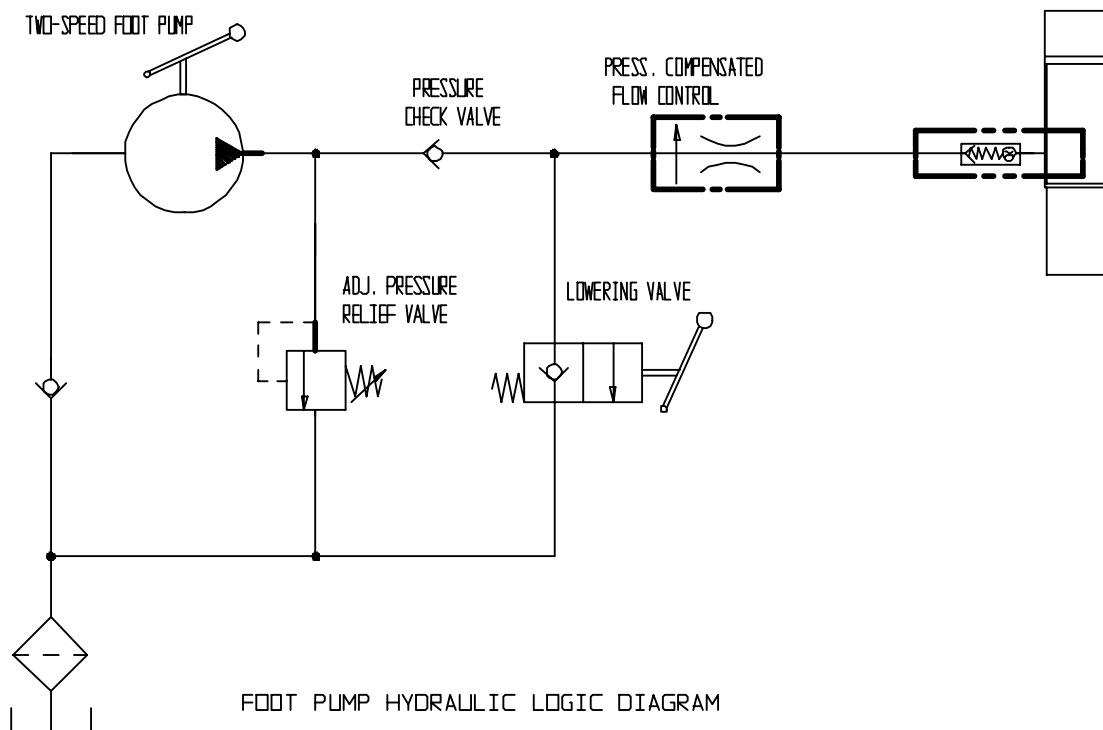

FOOT PUMP HYDRAULIC LOGIC DIAGRAM

## THE POWER UNIT'S OPERATION – EHLT (1-4K) & PST (1-3K)

The electric / hydraulic scissor lift utilizes an electric motor directly coupled to a gear-type hydraulic pump to produce the needed fluid pressure and flow to allow the cylinders to perform the work of lifting the platform load. A hydraulic manifold houses the hydraulic control components, and is bolted directly onto the gear pump.

The power unit's hydraulic components are all rated for 3,000 psi working pressure.

↗ Important parts of the power unit include:

- The electric motor. Motors are available for operation on single- or three-phase AC supplies (all are dual-voltage), or a 12 VDC battery (portable units).
- The gear pump. Its shaft is coupled directly to the shaft of the electric motor. Several displacements are available, depending on the motor horsepower used.
- The check valve. Its purpose is to prevent the backflow of fluid through the pump. In this way it allows the platform to be held at a given elevation indefinitely.
- The pressure relief valve. Its job is to open a path for fluid to flow back to the reservoir in the event that the fluid pressure built up by the pump exceeds 3,000 psi. Thus the pump cannot generate more than 3,000 psi.
- The lowering solenoid valve. This is an electrically-operated cartridge valve. It contains a screen to keep contaminants from entering the valve.
- The pressure-compensated flow control spool. This is installed in a port beside the lowering valve, and regulates the fluid flow back to the reservoir when the valve opens. It allows the table to always lower at the same rate regardless of whether there is a load on the platform or not. Several flow rates are available.
- The hydraulic lift cylinder(s). These are displacement-style cylinders. They have a bleeder valve located at their top end to allow air to be bled from the hydraulic system.
- The safety velocity fuse. This is a device that is installed in the cylinder's hose port. It closes quickly in the event of a catastrophic hose failure to prevent the lift from collapsing down. The platform remains stationary until pressure is reapplied to the cylinder.
- The hydraulic fluid. The system uses HO150 hydraulic fluid. Any anti-wear hydraulic oil with a viscosity grade of 150 SUS at 100°F (ISO 32 at 40°C) such as AW 32 or a non-synthetic transmission fluid is acceptable.

When the platform is to be raised, press the "UP" pushbutton or foot switch. The motor turns, and in turning it spins the hydraulic gear pump. Oil is drawn from the reservoir through the suction filter and into the pump. The pump pushes the then-pressurized oil through the check valve and out to the lift cylinders.

When the platform is to be lowered, press the "DOWN" pushbutton or foot switch. The lowering valve opens, bypassing the check valve and allowing the oil in the cylinders to return back to the reservoir through the return hose. The rate at which the platform lowers is regulated by the internal pressure-compensated flow spool.

↗ In the event that the platform creeps down slowly after releasing the "DOWN" control, it will be necessary to remove the lowering cartridge valve for inspection and cleaning, as follows:

- ◆ Remove any load from the platform.
- ◆ *Warning:* Raise the lift and install the maintenance props. Lower the platform until the lift rests on the props.
- ◆ Remove the nut holding the solenoid coil on the valve stem, then remove the coil, and then unscrew the valve from the manifold.
- ◆ Inspect the valve for contaminants, and the valve's o-rings and back-up washers for cuts, tears, or other damage.
- ◆ With the valve immersed in mineral spirits or kerosene, use a thin tool such as a small screwdriver or a small hex wrench to push the poppet in and out several times from the bottom end of the valve. The valve should move freely, about 1/16" from closed to open position. If it sticks in, the valve stem could be bent and will need to be replaced if it doesn't free up after cleaning. Blow the valve off with a compressed-air gun while again pushing the poppet in and out.
- ◆ Inspect the bottom of the manifold's valve cavity for contaminants.
- ◆ Remove the plug located in the corner of the manifold next to the lowering valve. Inspect for contaminants that might be plugging up the flow control located at the bottom of the cavity.
- ◆ With the thin tool, press down on the center of the flow control spool. It should move down and back up freely.
- ◆ Reinstall the plug, then the valve, tightening the valve with approximately 20 lb-ft of torque.

↗ If the platform lowers extremely slowly, or not at all, the cylinder's velocity fuse could be closing. This can be caused by air in the hydraulic cylinders.

*To bleed the air from the system:*

- ◆ Remove any load from the platform.
- ◆ *Warning:* Raise the lift and install the safety maintenance props. Lower the platform until the rollers nearly rest on the props.

Hold a rag over the cylinder's bleeder valve (it looks like a grease zirk) and open the valve about 1/2 turn with a 1/4" wrench. Oil and air will sputter from the valve - once no air is observed, close the valve.

## DC MODULAR POWER UNIT PARTS BREAKDOWN -- PST (1-3K)

- Note: Motors, cylinders, and pumps can vary by model. Consult the manufacturer to determine the exact part numbers for these items.

REV.	ENG #	REV.	ECR #	DATE	REVISIONS	INITIAL
	073003JY-1A					

ITEM	REQ	PART NO.	DESCRIPTION
1	1	4JY1119	BASE
2	1	1212SR	BATTERY CHARGER
3	1	01-033-024	18/3 W4 PIN PLUG
4	4	37927	TINNERMAN CLIP
5	1	99-023-001	RESERVOIR
6	1	99-034-013	BATTERY STRAP
7	1	24DC36	BATTERY
8	1	BV-48	BREATHER
9	1	15-533-013	CABLE, BATTERY 23" BLACK
10	1	15-533-014	CABLE, BATTERY 23" RED
11	2	23305	SHCS UTILITY GRADE
	2	33688	HIGH COLLAR LOCK WASHER
	2	33008	USS FLAT WASHER Z PLATED
12	1	99-135-011	MOTOR, 12VDC
13	1	15-022-004	RELAY, START SOLENOID
14	1	HS64	CLAMP, WORM GEAR
15	1	BG-12V	GAUGE, BATTERY INDICATOR
16	3	ZB2BZ009	BASE, CONTACT BLOCK
17	3	ZB2BE101	CONTACT BLOCK N.O.
18	2	ZB2BA2C	OPERTOR, BLACK, NON-ILLUM.
19	1		KEY SWITCH, 2 POSITION
20	1	01-134-007	LEGEND, ON - OFF
21	1	091802JY	FIBERGLASS COVER
22	1	HS52	CLAMP, WORM GEAR
23	1	01-143-906	PUMP
24	1	01-627-010	MANIFOLD ASSM (SEE PAGE 2)
25	2	29201	TPHMS, Z PLATED
26	2	29185	TPHMS, Z PLATED
27	4	23255	SHCS UTILITY GRADE
	4	33687	HIGH COLLAR LOCK WASHER
28	1	152400-03	MOLDED CORD
29	1	150CCTM.OEM	CONNECTOR, CHARGE
30	10"	3MT ST3540	1"HOOK&LOPPRESS SENSITIVE

REMOVE ALL BURRS AND SHARP EDGES		
CONCENTRIC	.006 TIR	.060 TIR
ANGLES	+/- .0° 30'	+/- 1° 0'
DECIMALS	xxx +/- .015 xxx +/- .010 xx +/- .025	+/- .015
FRACTIONS	+/- 1/32	+/- 1/16
TOLERANCE	MACHINE	WELDMENT

THIS PRINT IS CONFIDENTIAL AND IS THE PROPERTY OF T & S EQUIPMENT CO. THIS PRINT SHALL NOT BE USED, COPIED OR REPRODUCED IN WHOLE OR IN PART NOR SHALL THE CONTENTS BE REVEALED ANY MANNER TO ANYONE UNLESS WRITTEN PERMISSION IS OBTAINED FROM T & S EQUIPMENT CO.

### T & S EQUIPMENT COMPANY

SCALE: INTS      APPROVED BY:      DRAWN BY: J.YOUNG

DATE: 07/30/03      SEE: A

## DC MODULAR POWER UNIT

MATERIAL:      DRAWING NUMBER: 073003JY-1A      REV:

## DC MODULAR POWER UNIT PARTS BREAKDOWN -- PST (1-3K)

- Note: Motors, cylinders, and pumps can vary by model. Consult the manufacturer to determine the exact part numbers for these items.

REV.	ENG #	REV.	EQR #	DATE	REVISIONS	INITIAL
	073003JY-1B					

ITEM	REQ	PART NO.	DESCRIPTION
31	1	568-015-BN70	O-RING
32	1	568-011-BN70	O-RING
33	1	99-153-015	VALVE, CARTRIDGE, NC
34	1	99-034-010	COIL, WEATHER TITE PLUG
35	1	99-153-006	VALVE, PRESSURE RELIEF
36	1	568-334-BN70	O-RING
37	1	99-531-005	FILTER
38	1	99-153-038	FLOW CONTROL, 1.0 GPM
39	1	01-127-010	MANIFOLD
40	1	6801-06-06-NOW	MJ-MAORB 90 DEG.
41	1	99-153-011	VALVE, CHECK

REMOVE ALL BURRS AND SHARP EDGES		
CONCENTRIC	.006 TIR	.060 TIR
ANGLES	+/- 0° 30'	+/- 1° 0'
DECIMALS	X.XXX +/- .005 X.XX +/- .010 X.X +/- .025	+/- .015
FRACTIONS	+/- 1/32	+/- 1/16
TOLERANCE	MACHINE	WELDMENT

<b>T &amp; S EQUIPMENT COMPANY</b>		
SCALE: NTS	APPROVED BY:	DRAWN BY: J.YOUNG
DATE: 07/30/03		SIZE: A
<b>DC MODULAR POWER UNIT</b>		
MATERIAL:	DRAWING NUMBER: 073003JY-1B	REV:

THIS PRINT IS CONFIDENTIAL AND IS THE PROPERTY OF T & S EQUIPMENT CO. THIS PRINT SHALL NOT BE USED, COPIED OR REPRODUCED IN WHOLE OR IN PART NOR SHALL THE CONTENTS BE REVEALED ANY MANNER TO ANYONE UNLESS WRITTEN PERMISSION IS OBTAINED FROM T & S EQUIPMENT CO.

## AC MODULAR POWER UNIT PARTS BREAKDOWN -- PST (1-3K)

- Note: Motors, cylinders, and pumps can vary by model. Consult the manufacturer to determine the exact part numbers for these items.

REV.	ECR#	DATE	REVISIONS	INITIAL

ITEM	REQ	PART NO.	DESCRIPTION
1	1	4JY1119	BASE
2	1		ELECTRIC BOX (SEE PAGE 2)
3	1	21-034-005	AC ADAPTER PLUG
4	4	37927	TINNERMAN CLIP
5	1	99-023-001	RESERVOIR
6	1		MOTOR BRACE
7	4	23255	SHCS UTILITY GRADE
8	4	33687	HIGH COLLAR LOCK WASHER
9	1	BV-48	BREATHER
10	2	29185	TPHMS, Z PLATED
11	2	29201	TPHMS, Z PLATED
12	2	23305	SHCS UTILITY GRADE
13	2	33688	HIGH COLLAR LOCK WASHER
14	2	33008	USS FLAT WASHER Z PLATED
15	1	01-627-010	MANIFOLD ASSM (SEE PAGE 2)
16	1	01-143-906	PUMP
17	1	HS52	CLAMP, WORM GEAR
18	1	091802JY	FIBERGLASS COVER
19	3	ZB2BZ009	BASE, CONTACT BLOCK
20	3	ZB2BE101	CONTACT BLOCK N.O.
21	2	ZB2BA2C	OPERATOR, BLACK, NON-ILLUM.
22	1	ZB2BG4C	SWITCH, KEY, 2 POSITION
23	1	01-134-007	LEGEND, ON - OFF
24	1	99-135-003	MOTOR, ELECTRIC, 1PH
25	6	11005	HHCS, Z PLATED
26	6	33004	USS FLAT WASHER, Z PLATED
27	6	33618	LOCK WASHER, Z PLATED
28	6	36102	HEX NUT, Z PLATED

REMOVE ALL BURS AND SHARP EDGES

	.000 TIR	.006 TIR
CONCENTRIC		
ANGLES	+/- .0° 30'	+/- .1° 0'
DECIMALS	x.xxx +/- .005 x.xx +/- .010 x.x +/- .025	+/- .015
FRACTIONS	+/- 1/32	+/- 1/16
TOLERANCE	MACHINE	WELDMET

T & S EQUIPMENT COMPANY

SCALE: NTS      APPROVED BY: \_\_\_\_\_

DATE: 07/30/03      DRAWN BY: J. YOUNG

AC MODULAR POWER UNIT

DRAWING NUMBER: 073003JY-2A      REV: \_\_\_\_\_

THIS PRINT IS CONFIDENTIAL AND IS THE PROPERTY OF T & S EQUIPMENT CO. THIS PRINT SHALL NOT BE USED, COPIED OR REPRODUCED IN WHOLE OR IN PART NOR SHALL THE CONTENTS BE REVEALED ANY MANNER TO ANYONE UNLESS WRITTEN PERMISSION IS OBTAINED FROM T & S EQUIPMENT CO.



### AC MODULAR POWER UNIT PARTS BREAKDOWN -- PST (1-3K)

- Note: Motors, cylinders, and pumps can vary by model. Consult the manufacturer to determine the exact part numbers for these items.

REV.	DWG #	REV.	ECR #	DATE	REVISIONS	INITIAL
	073003JY-2B					

ITEM	REQ	PART NO.	DESCRIPTION
1	4	71616	TSHMS. SS
2	1	01-129-001	TRANSFORMER
3	1	132560	CONTACTOR, MOTOR
4	4	27531	PHSMS, Z PLATED
5	4	32028	HWH TEK DRILL & TAP
6	3"	TB-TRACK	RAIL, DIN
7	1	01-029-006	JUNCTION BOX
8	1	AB66JP	PANEL, JUNCTION BOX
9	4	C500	CONNECTOR, ROMEX, 2 SCREW
10	1	01-127-010	MANIFOLD
11	1	6801-06-06-NOW	MJ-MAORB 90 DEG.
12	1	99-153-011	VALVE, CHECK
13	1	568-015-BN70	O-RING
14	1	568-011-BN70	O-RING
15	1	99-153-015	VALVE, CARTRIDGE, NC
16	1	99-034-008	COIL, 24V AC
17	1	99-153-006	VALVE, PRESSURE RELIEF
18	1	568-334-BN70	O-RING
19	1	99-531-005	FILTER
20	1	99-153-038	FLOW CONTROL, 1.0 GPM

REMOVE ALL BURRS AND SHARP EDGES		
CONCENTRIC	.004 TIR	.040 TIR
ANGLES	+/- 0° 30'	+/- 1° 0'
DECIMALS	x.xxx +/- .005 x.xx +/- .010 x.x +/- .025	+/- .015
FRACTIONS	+/- 1/32	+/- 1/16
TOLERANCE	MACHINE	WELDMENT

T & S EQUIPMENT COMPANY

SCALE: NDS	APPROVED BY:	DRAWN BY: J. YOUNG
DATE: 07/03/03		SIZE: A
AC MODULAR POWER UNIT		
MATERIAL:	DRAWING NUMBER: 073003JY-2B	REV:

THIS PRINT IS CONFIDENTIAL AND IS THE PROPERTY OF T & S EQUIPMENT CO. THIS PRINT SHALL NOT BE USED, COPIED OR REPRODUCED IN WHOLE OR IN PART NOR SHALL THE CONTENTS BE REVEALED ANY MANNER TO ANYONE UNLESS WRITTEN PERMISSION IS OBTAINED FROM T & S EQUIPMENT CO.

## TROUBLESHOOTING GUIDE -- EHLT (1-4K) & PST (1-3K)

- **WARNING:** Care should be taken to identify all potential hazards and comply with all applicable safety procedures before beginning troubleshooting or repairs. Disconnect or disable all energy sources utilizing proper lock-out/tag-out procedures.
- **CAUTION:** Before performing any troubleshooting or repairs, the load must be removed from the platform. Then either raise the platform and install the maintenance props or fully lower the platform to the floor.
- Only qualified individuals trained to understand mechanical devices and their associated electrical and hydraulic circuits, along with the hazards that could result from them, should attempt troubleshooting and repair of this equipment.

Consult the factory for any problems not addressed in this manual.

- \* Check the DC notes page for troubleshooting other problems specific to batteries and chargers.

<u>Problem:</u>	<u>Possible cause(s):</u>	<u>Action:</u>
Power unit doesn't run when "UP" button is pressed.	Transformer fuse is blown. No supply voltage.  Upper-travel limit switch is engaged or bad. Bad control transformer. Bad motor relay coil. Bad solenoid start switch (DC units).  Battery voltage low (DC units).	Test with meter; replace if bad. Test with meter. Check fuses, breakers, and overloads to determine the cause. Inspect, test switch. Replace if bad. Check for 24 VAC; replace if bad. Test with meter; replace if bad. The green LED on motor relay will be off, or will turn off when the UP pushbutton is pressed. Test with meter. Charge battery if low (is motor relay LED on?)
Motor runs, platform doesn't move. Power unit not noisy.	Motor rotation is wrong (AC-powered units only). Pump is failing to build pressure.	Verify the motor runs CW, opposite the shaft end. Consult factory.
Motor hums or pump squeals, but the platform does not move, or the platform moves only slowly.	See last paragraph, above. Excess voltage drop to motor, due to power wire size too small, wire run too long, or incoming voltage too low. Motor is "single-phasing".  Pressure relief opening at full pressure.	Same as above. Check power installation for adequacy. Check incoming voltage <i>while motor is running</i> . Correct problem found. Determine cause of loss of voltage on one phase; correct. Check for structural damage or binding of the scissor legs, etc. Check for platform overload condition.
Platform raises, then drifts down. Spongy or jerky platform movement.	Contamination holding open the lowering valve or the check valve. See last paragraph, above. Excessive air in the hydraulic cylinders.	Remove and inspect. Clean per instructions in "Power Unit Operation." Same as above. Bleed air per procedure described in "Power Unit Operation."
Platform won't lower.	Toe guard is actuated.  Toe guard switch, or wire, broken.  Solenoid coil is bad.  Physical blockage of the structure.	Check for a toe guard extrusion or rubber corner that is stuck. Adjust if necessary. Inspect visually, check with multimeter. Repair as needed. Check with multimeter on diode-check function. (Reading for ohms will not provide an accurate test of the coil.) Inspect for foreign material or objects that might block the leg set or its rollers.
Platform lowers too slowly.	Solenoid valve, flow control, or suction hose screen plugged. Pinched hose.  Velocity fuse locking (platform only slowly creeps down). Flow control spool sticking.	Remove and inspect. Clean per instructions in "Power Unit Operation." Check pressure, supply, and return hoses for kinks. Same as for jerky platform movement.  Remove plug from FC port; push on flow spool to ensure it is fully pressed into the cavity. Pull and clean the spool if necessary.
Platform lowers too quickly.	See last paragraph, above.	Same as above.

# SAFETY LABEL IDENTIFICATION

\* Product safety signs or labels should be periodically inspected and cleaned by the product users as necessary to maintain good legibility for safe viewing distance -- ANSI 535.4 (10.21). Contact the manufacturer for replacement labels.

**On AI Trim w/ Accordion Skirting**

**207** Opposite Corners

**MADE IN U.S.A. 2 x 2**

**Both Sides**

**208**

**Both Sides On Maintenance Prop**

**223**

**Both Sides**

**269**

**221**

**248 - 251**

**Alternating Corners**

**204**

**206**

**207**

**208**

**223**

**269**

**248 - 251**

**204**

**206**

**On AI Trim w/ Accordion Skirting**

**207**

**Alternating Corners**

**MADE IN U.S.A.**

**Date Label On frame w/ Accordion Skirting**

**Both Sides**

**208**

**Both Sides**

**269**

**Both Sides**

**223**

**376**

**377**

**Inside by Fill Plug**

**206**

**295**

**207**

**208**

**269**

**223**

**376**

**377**

**206**

**295**

## **PRODUCT WARRANTY**

### **ONE YEAR LIMITED WARRANTY**

The manufacturer warrants for the original purchaser against defects in materials and workmanship under normal use for one year after date of shipment (not to exceed 18 months after date of manufacture). Any part that is determined by the manufacturer to be defective in material or workmanship and returned to the factory, shipping costs prepaid, will be, as the exclusive remedy, repaired or replaced at our option. Labor costs for warranty repairs and/or modifications are not covered unless pre-approved by the manufacturer or done at the manufacturer's facilities. Any modifications performed without prior written approval of the manufacturer may void warranty. This limited warranty gives purchaser specific legal rights which vary from state to state.

All specifications are subject to change without notice.

### **LIMITATION OF LIABILITY**

To the extent allowable under applicable law, the manufacturer's liability for consequential and incidental damages is expressly disclaimed. The manufacturer's liability in any event is limited to, and shall not exceed, the purchase price paid. Misuse or modification may void warranty.

Warranty does not cover labor or consequential damages including, but not limited to, business interruption costs, lost profits, or lost business opportunities.

### **WARRANTY DISCLAIMER**

The manufacturer has made a diligent effort to accurately illustrate and describe their products. However, such illustrations and descriptions are for the sole purpose of identification, and do not express or imply a warranty that the products are merchantable or fit for a particular purpose, or that the products will necessarily conform to the illustrations or descriptions.

The provisions of the warranty shall be construed and enforced in accordance with the Uniform Commercial Code and laws as enacted in the State of Indiana.

### **DISPOSITION**

Our company will make a good faith effort for prompt correction or other adjustment with respect to any product that proves to be defective within the Limited Warranty Period. Warranty claims must be made in writing within said year.