

DRUM HOIST CARRIER/ROTATOR - DCT-85

APPROX WEIGHT: 84.59 lbs.
DOES NOT INCLUDE WEIGHT OF POWER OR PACKAGING!!!

*** ANY ADDITIONS, DELETIONS, OR OMISSIONS MUST BE CORRECTED ON THIS DRAWING AS THIS DRAWING WILL BE CONSIDERED ALL INCLUSIVE ***

ALL GRAPHICS PROVIDED ARE FOR REFERENCE ONLY. IF CERTAIN DIMENSIONS ARE CRITICAL PLEASE VERIFY THOSE DIMENSIONS WITH YOUR SALESPERSON

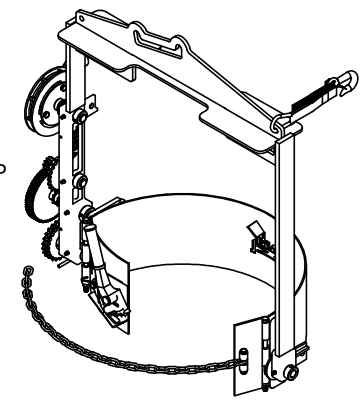
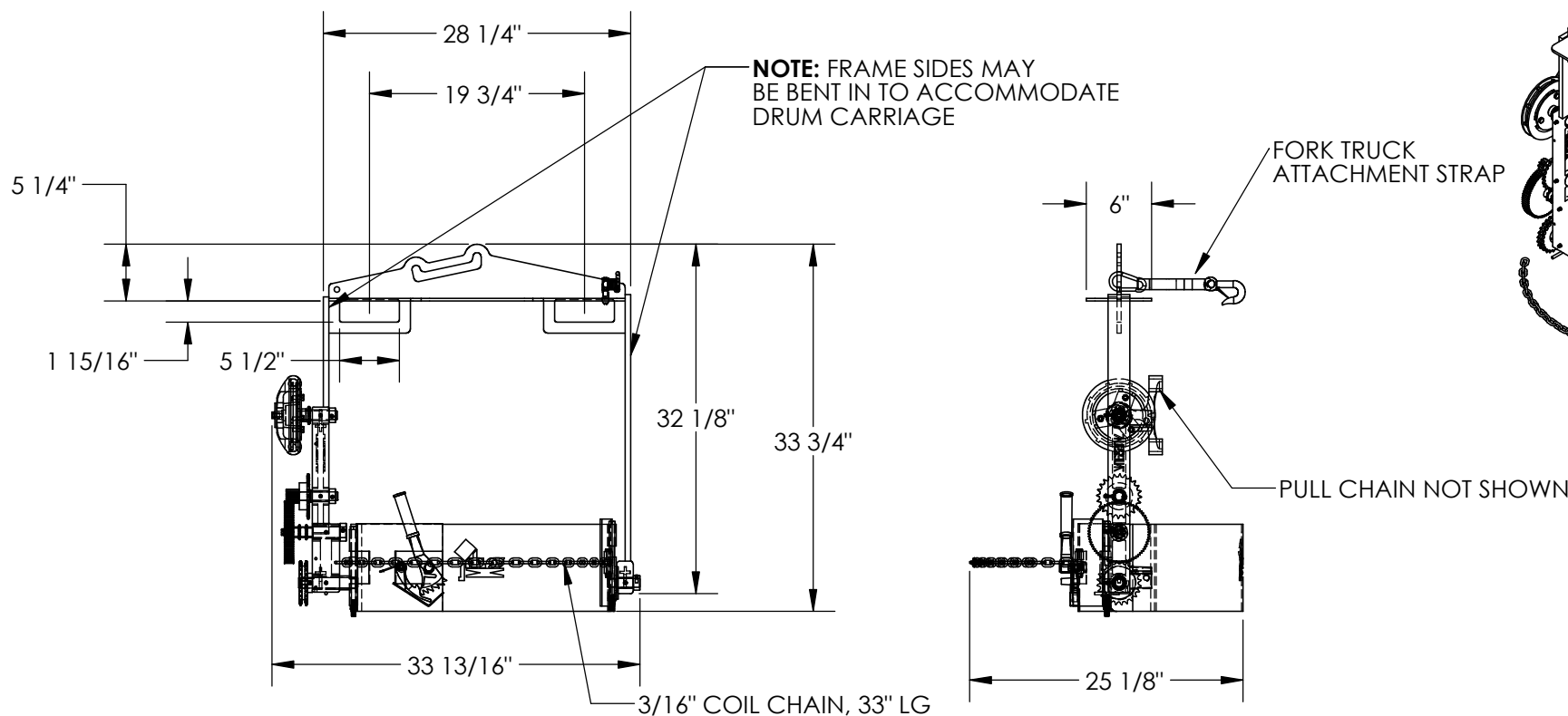

DIMENSION TOLERANCE ± 1/4"

STANDARD FEATURES

- MODEL NUMBER IS DCT-85
- ROTATION METHOD: 15' CHAIN
- ACCEPTS 55 GALLON STEEL DRUMS
- MAX CAPACITY: 1500 LBS.
- FORK POCKETS (5 1/2" X 1 15/16")
- FORK TRUCK ATTACHMENT STRAP
- TWO POSITION LIFTING BAIL

SPECIAL FEATURES

NONE

OPTIONS (AVAILABLE AT EXTRA COST)

- HAND CRANK: DCT-R-HC
- FIBER DRUM ADAPTER: FDA-800
- 30 GALLON STEEL SADDLE: FDC-30

APPROVAL

I, THE UNDERSIGNED, AGREE THAT THE PRODUCT AS REPRESENTED SATISFIES DESIGN AND DIMENSION REQUIREMENTS. I ALSO ACKNOWLEDGE MY DUTY TO CONFIRM PRODUCT AND INSTALLATION COMPLIANCE WITH ALL APPLICABLE FEDERAL, STATE AND LOCAL REGULATIONS AND STANDARDS.

ALL SPECIAL UNITS ARE NON-RETURNABLE

[] As drawn [] As marked

Signed: _____ Date: _____

LEAD TIME WILL START UPON RECEIPT OF SIGNED APPROVAL DRAWING

FOR INTERNAL USE ONLY PROJECT SIGN OFF	
SALES	
ENG.	
FAB.	
POWER	

DISTRIBUTOR'S NAME:		P.O.#
VESTIL MANUFACTURING		X
DRAWN BY:	DATE:	W.O.#
X	XX/XX/XX	X
REFERENCE:	SCALE:	SALES:
X	1:16	X
QUOTED LEAD TIME:	QUOTE #	FILE NAME:
X	X	40-007-015