

CYLINDER CART - CYHT-2

APPROX WEIGHT: 74.15 lbs.
DOES NOT INCLUDE WEIGHT OF POWER OR PACKAGING!!!

*** ANY ADDITIONS, DELETIONS, OR OMISSIONS MUST BE CORRECTED ON THIS DRAWING AS THIS DRAWING WILL BE CONSIDERED ALL INCLUSIVE ***

ALL GRAPHICS PROVIDED ARE FOR REFERENCE ONLY. IF CERTAIN DIMENSIONS ARE CRITICAL PLEASE VERIFY THOSE DIMENSIONS WITH YOUR SALESPERSON

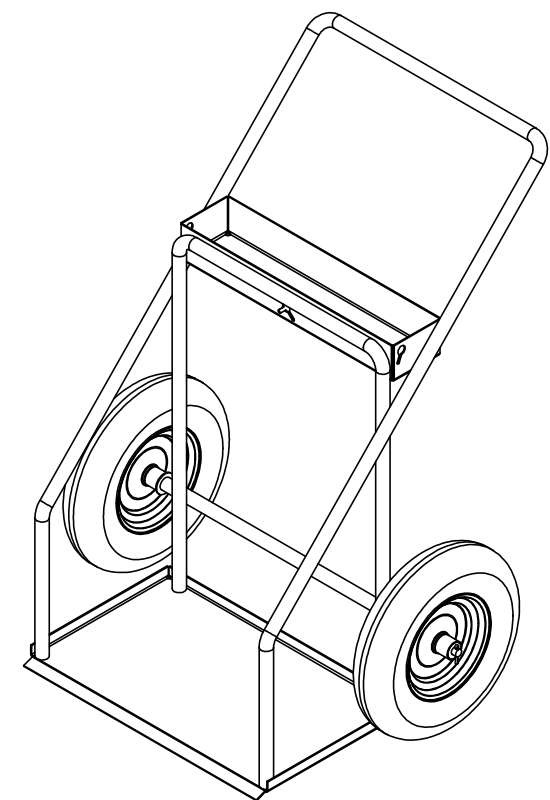
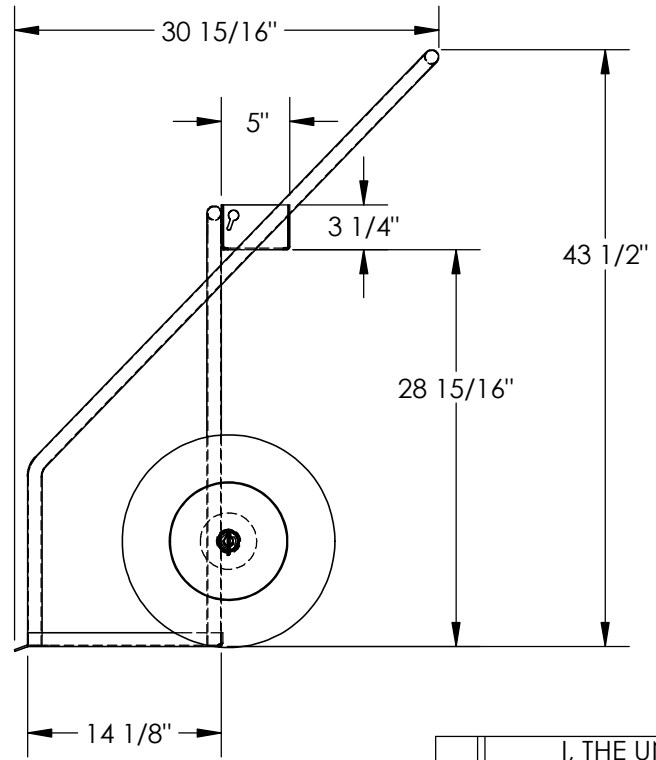
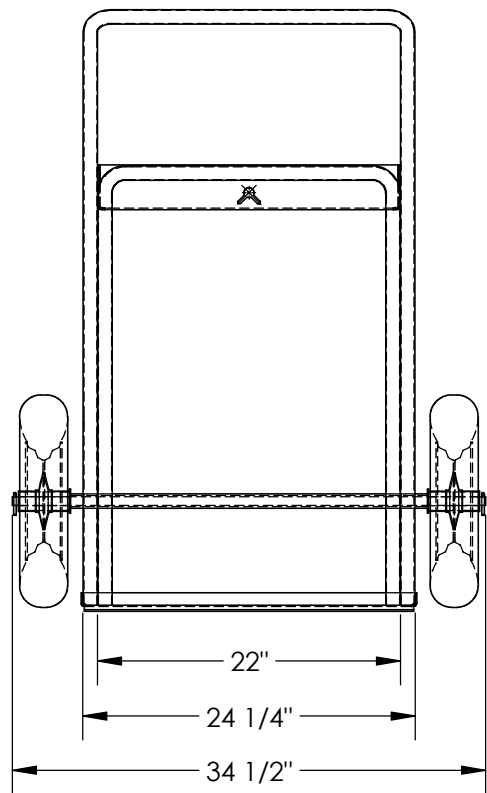

DIMENSION TOLERANCE ± 1/4"

STANDARD FEATURES

- MODEL NUMBER IS CYHT-2
- UNIFORM CAPACITY IS 250 LBS.
- OVERALL WIDTH IS 34 1/2"
- USABLE WIDTH IS 22"
- OVERALL LENGTH IS 30 15/16"
- USABLE LENGTH IS 14 1/8"
- OVERALL HEIGHT IS 43 1/2"
- CHAIN
 - Ø3/16" DOUBLE TWIST X 90" LG (NOT SHOWN)

SPECIAL FEATURES

NONE

APPROVAL

I, THE UNDERSIGNED, AGREE THAT THE PRODUCT AS REPRESENTED SATISFIES DESIGN AND DIMENSION REQUIREMENTS. I ALSO ACKNOWLEDGE MY DUTY TO CONFIRM PRODUCT AND INSTALLATION COMPLIANCE WITH ALL APPLICABLE FEDERAL, STATE AND LOCAL REGULATIONS AND STANDARDS.

ANY MODIFIED UNITS ARE NON-RETURNABLE

As drawn As marked

Signed: _____ Date: _____

Printed Name: _____

LEAD TIME WILL START UPON RECEIPT OF SIGNED APPROVAL DRAWING

FOR INTERNAL USE ONLY PROJECT SIGN OFF	
SALES	
ENG.	
FAB.	
POWER	

DISTRIBUTOR'S NAME:		P.O.#
VESTIL MANUFACTURING		X
DRAWN BY: CA	DATE: 04/13/2012	W.O.#
REFERENCE: X	SCALE: 1:14	X
QUOTED LEAD TIME: X	QUOTE #	FILE NAME:
	X	16-007-319