

COUNTER BALANCED FLOOR CRANE - CBFC-500

*** ANY ADDITIONS, DELETIONS, OR OMISSIONS MUST BE CORRECTED ON THIS DRAWING AS THIS DRAWING WILL BE CONSIDERED ALL INCLUSIVE ***
 ALL GRAPHICS PROVIDED ARE FOR REFERENCE ONLY. IF CERTAIN DIMENSIONS ARE CRITICAL PLEASE VERIFY THOSE DIMENSIONS WITH YOUR SALESPERSON

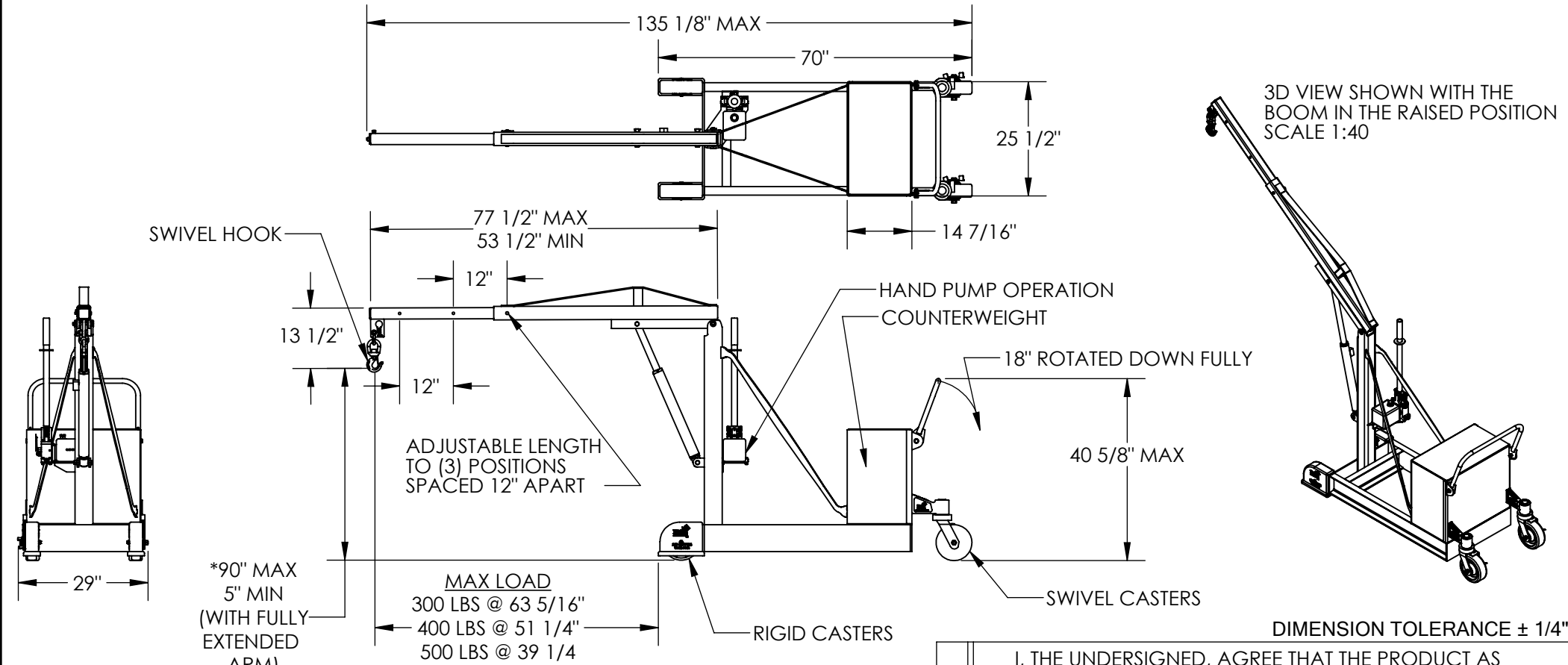

*WHEN BOOM IS FULLY RETRACTED AND THE CYLINDER IS FULLY RETRACTED HOOK HEIGHT IS 16 7/16"
 *WHEN BOOM IS FULLY RETRACTED AND THE CYLINDER IS FULLY EXTENDED HOOK HEIGHT IS 74 7/16"

STANDARD FEATURES

MODEL NUMBER IS CBFC-500
 OVERALL WIDTH IS 29"
 OVERALL LENGTH IS 135 1/8" MAX
 OVERALL HEIGHT IS 102" MAX
 MAX CAPACITY IS 500 LBS
 HAND PUMP OPERATION
 UNIT IS DURABLE LIQUID PAINT BLUE FINISH
 INNER BOOM IS DURABLE LIQUID PAINT YELLOW FINISH
 APPROX. SHIPPING WEIGHT: 1,259 LBS

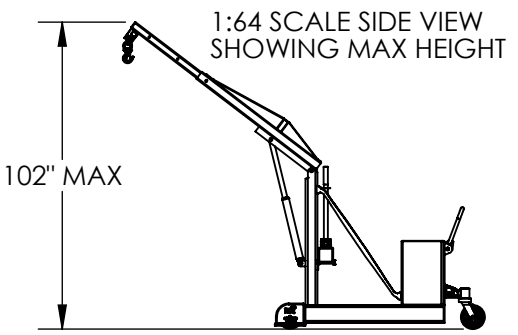

SPECIAL FEATURES

NONE

APPROVAL

I, THE UNDERSIGNED, AGREE THAT THE PRODUCT AS REPRESENTED SATISFIES DESIGN AND DIMENSION REQUIREMENTS. I ALSO ACKNOWLEDGE MY DUTY TO CONFIRM PRODUCT AND INSTALLATION COMPLIANCE WITH ALL APPLICABLE FEDERAL, STATE AND LOCAL REGULATIONS AND STANDARDS.
UNITS REQUIRING APPROVAL DRAWINGS OR MODIFIED ARE NON-RETURNABLE
 As drawn As marked

Signed: _____ Date: _____
 Printed Name: _____

LEAD TIME WILL START UPON RECEIPT OF SIGNED APPROVAL DRAWING

DISTRIBUTOR'S NAME:		P.O.#
VESTIL MANUFACTURING		X
DRAWN BY: MTS		W.O.#
DATE: 6/12/2013		X
REFERENCE: X	SCALE: 1:32	SALES: X
QUOTED LEAD TIME: X	QUOTE # X	FILE NAME:
		16-007-370