



## VESTIL MANUFACTURING CORP.

2999 North Wayne Street, P.O. Box 507, Angola, IN 46703

Telephone: (260) 665-7586 -or- Toll Free (800) 348-0868

Fax: (260) 665-1339

[www.vestilmfg.com](http://www.vestilmfg.com) e-mail: [sales@vestil.com](mailto:sales@vestil.com)

# SWA-Series Semi-Automatic Stretch Wrapping Machines Instruction Manual



### **Receiving instructions:**

After delivery, IMMEDIATELY remove the packaging from the product in a manner that preserves the packaging and maintains the orientation of the product in the packaging; then inspect the product closely to determine whether it sustained damage during transport. **If damage is discovered during the inspection, immediately record a complete description of the damage on the bill of lading.** If the product is undamaged, discard the packaging.

### **NOTES:**

1) Compliance with laws, regulations, codes, and non-voluntary standards enforced in the location where the product is *used* is exclusively the responsibility of the owner/end-user.

2) VESTIL is **not liable** for any injury or property damage that occurs as a consequence of failing to apply either:  
a) Instructions in this manual; or b) Information provided on labels affixed to the product. Neither is Vestil responsible for *any* consequential damages sustained as a result of failing to exercise sound judgment while assembling, installing, using or maintaining this product.

# **INDEX**

1 Introduction.....	1
2 Machine Dimension .....	2
3 Safety Instruction .....	3
3-1 Warning labels.....	3
3-2 Safety devices of turning table & interlocking function of safety guard .....	4
3-3 Safety guards.....	5
3-4 Moving elements.....	6
3-5 Safety related components.....	7
4 Installation of the machine.....	8
4-1 Setting the machine and choosing base.....	8
4-2 Packing and Unpacking.....	8
4-3 Handling and Transportation.....	10
4-4 Installation of machine.....	11
4-5 Assemble the Pre-stretch Unit.....	12
5 Control Panel.....	13
5-1 Description of key pad's function on the control panel.....	14
5-2 Wrapping function control.....	16
5-3 Status indication .....	18
5-4 Breakdown indication.....	20
5-5 Motion indication .....	21
6 Film Loading.....	23
7 Film Tension Adjust .....	24
8 Operation Procedure .....	25
9 Maintenance.....	26
9-1 Installing and removing turntable .....	26
9-2 Adjusting tightness of turntable chain.....	27
10 Electrical .....	28
10-1 Parts list of electrical components .....	28
10-2 EMC component list.....	33
10-3 Electrical wiring diagram .....	34
11 Troubleshooting.....	46
11-1-1 Power indication hasn't lighted on.....	46
11-1-2 There isn't DC12 Volt. On power supply PD-25A .....	47

11-1-3 There isn't DC24 Volt. On power supply PS-65-24.....	48
11-2-1 Turntable motor not operating (Inverter) .....	49
11-2-2 Turntable motor Speed not adjustable.....	49
11-3-1 Film-seat motor brake (BK2) not working.....	50
11-3-2 Film-seat elevator motor not rising .....	51
11-3-3 Film-seat elevator motor not rising .....	52
11-4 Film-seat doesn't stop when reached package limit .....	53
11-5 Film-seat doesn't pause .....	53
11-6-1 Film-seat doesn't stop after reaching maximum packaging limit.....	54
11-6-2 Film-seat doesn't stop after returning to starting position .....	54
11-6-3 Film-seat motor speed not adjustable .....	55
11-7-1 Turntable hasn't slowed down before completing wrapping cycle.....	55
11-7-2 Turntable doesn't stop after completing wrapping cycle .....	56
11-8 LS1, LS2, PS1, PS2 & PH not operating normally on PC board KS-050202-key .....	56
11-9 Control panel buttons not working .....	57
11-10 Pre-stretch motor M3 hasn't worked .....	58
12 Machine parts diagram.....	60
13-1-1 Fig-11000 Pillar parts diagram.....	61
12-1-2 Fig-11000 Pillar parts table .....	62
12-2-1 Fig-12000 Film-seat elevator parts diagram .....	65
12-2-2 Fig-12000 Film-seat elevator parts table .....	66
12-3-1 Fig-14000 Bottom plate diagram .....	67
12-3-2 Fig-14000 Bottom plate parts table.....	68
12-4-1 Fig-18000 Control box diagram.....	70
12-4-2 Fig-18000 Control box table .....	71
12-5-1 Fig-18100 Control box diagram.....	74
12-5-2 Fig-18100 Control box table .....	75
12-6-1 Fig-19000 Pre-Stretch Unit diagram.....	76
12-6-2 Fig-19000 Pre-Stretch Unit table .....	77
12-7-1 Fig-19100 Pre-Stretch Unit diagram.....	82
12-7-2 Fig-19100 Pre-Stretch Unit table .....	83
13 Parts list.....	84

# 1 Introduction

Thank you for purchasing a state-of-the-art Vestil Mfg. stretch film pallet wrapping machine. All of us at Vestil Mfg. would like to express our gratitude, and our desire to continue serving you in the best possible way.

Please read all the instructions in this User's Guide before attempting to operate the machine. This will enable you to operate the machine safely and at peak efficiency. We have made every effort to ensure that all information in this Guide is up to date. However, our commitment to continuously improve all our products may result in you receiving a machine that does not conform exactly to these instructions. Since we are quick to take advantage of new technology as it becomes available, we must reserve the right to change our products and User's Guide without prior notice.

All our distributors are fully knowledgeable about all aspects of our products. If you have any need for advice or service, please do not hesitate to call upon them.

## 2 Machine Dimension

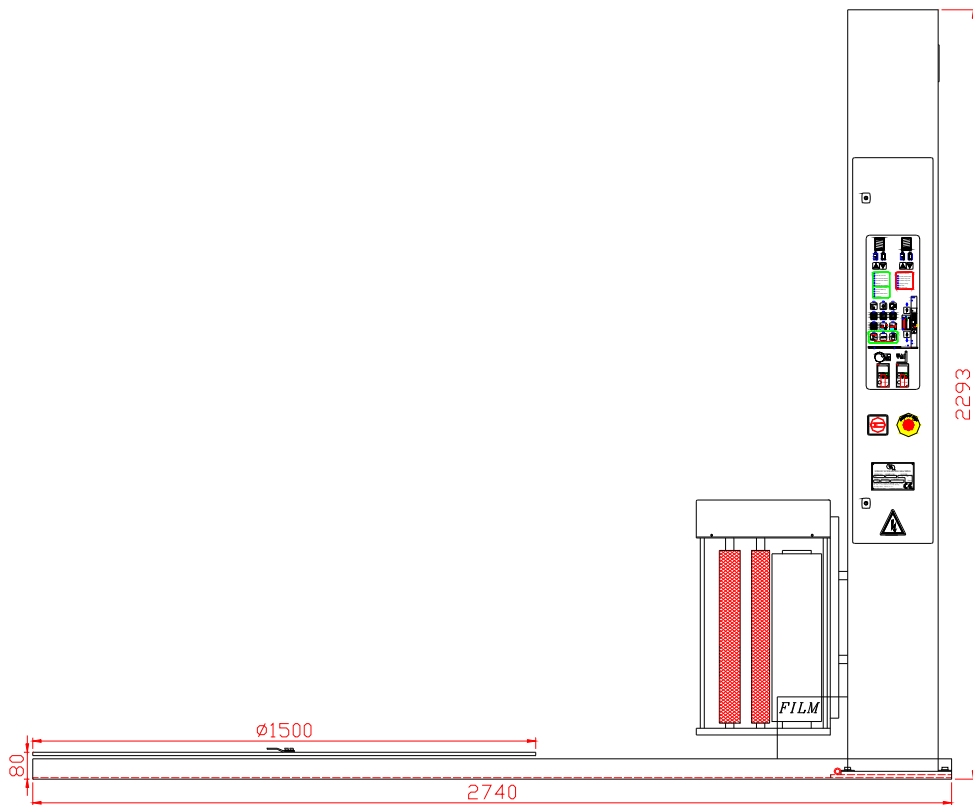
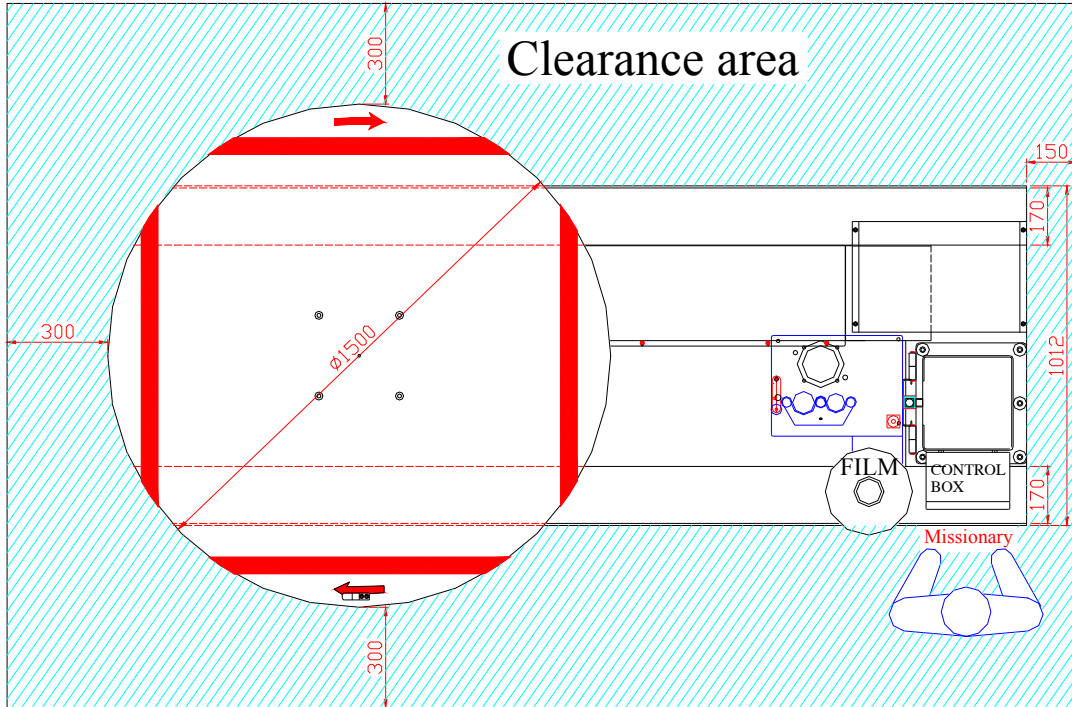





Model	L	W	H
SWA-60-AW 40r	108"	60"	90-1/4"

Turntable	Weight
Ø 60"	1169 lbs

### 3 Safety Cautions

#### 3-1 Warning labels

Dangerous Area and Working Environment		
Dangerous Location	Precaution	Marking Label
The dangerous location is inside the control panel.	Hazardous voltage. Turn power of f before open the panel.	
The dangerous location is inside the right and left rising & descending columns.	Keep hand, cloths and body clear o f the rotating chain. If hand tangled into the chain and sprocket can cause severe injury.	
The dangerous location is in m otor reduction gear head.	Keep hand, cloths and body clear o f the rotating gears. If hand tangled into the gears can cause severe injury.	
Dangerous location is on the driving rollers of the pre-stretch unit. So, we have stuck the label on the fixed guard of the rollers.	Drawing-in hazard caused by driving rollers.	
The dangerous location is on the tape cutter	Keep hand away from the cutter. If hand placed under the cutter and the cutter move downward can cause severe injury.	

### 3-2 Safety devices of turning table & interlocking function of safety guard

Buttons of emergency stop are SB1 which would disconnect to main power and SB2 which would disconnect to controller.

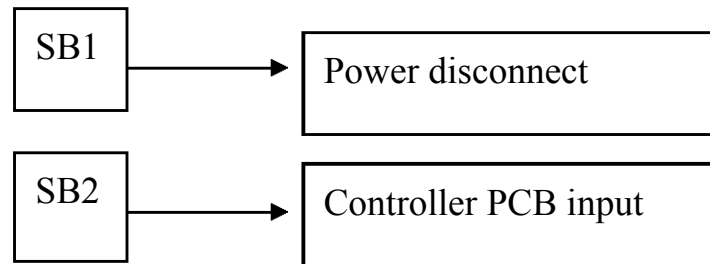

### 3-3 Safety guards

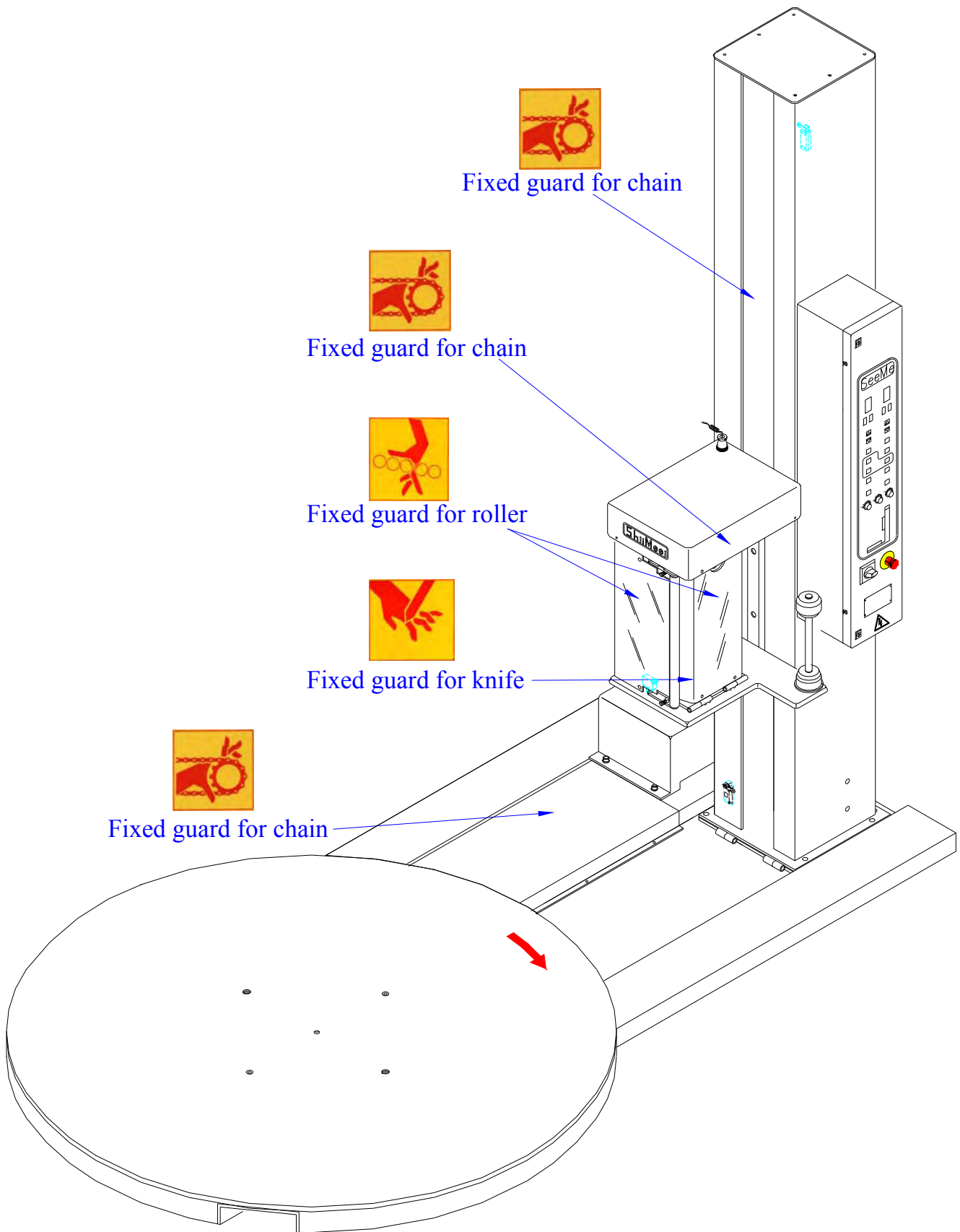



### 3-4 Moving elements

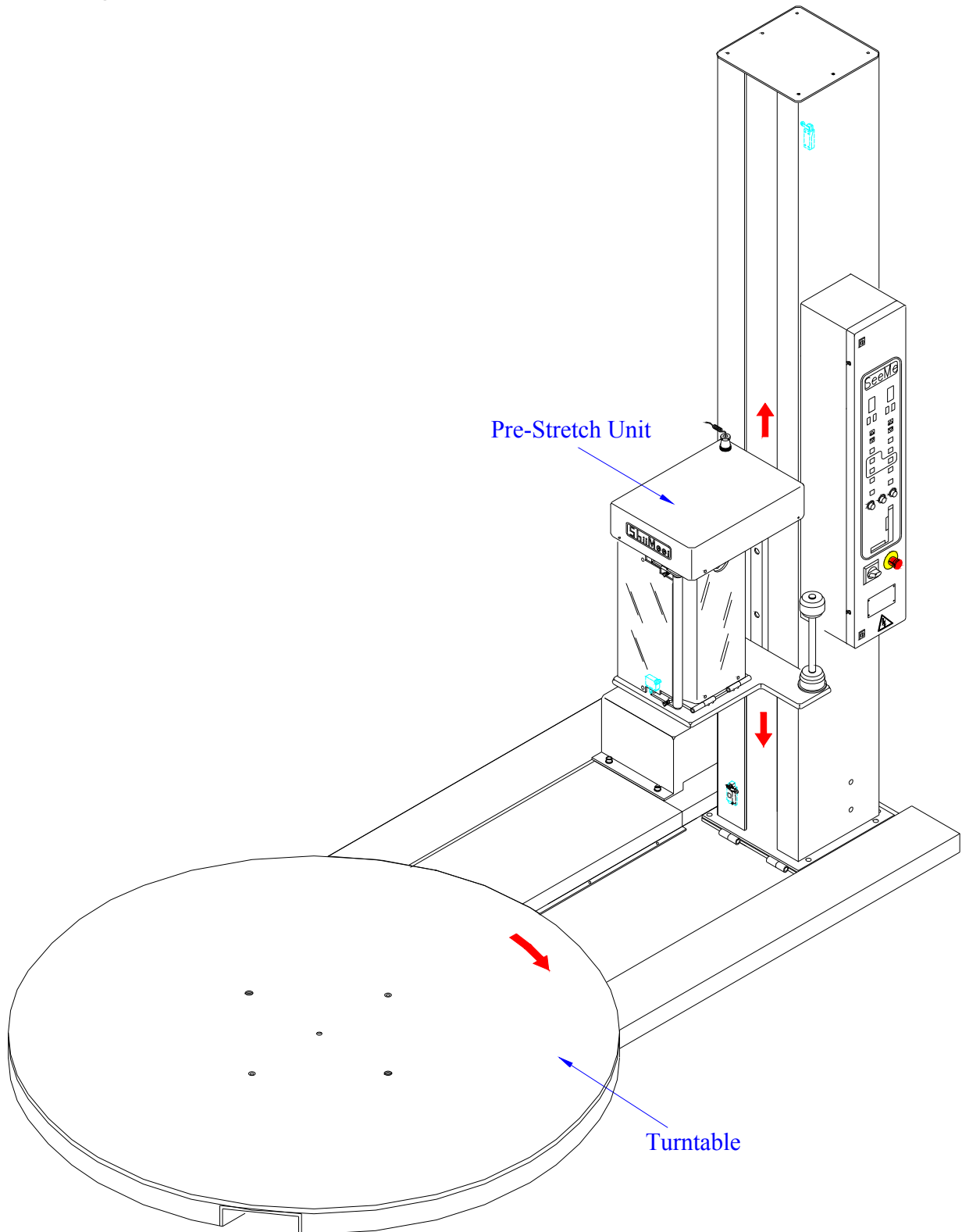

Moving parts name	Movement	Power source
Pre-Stretch Unit	Up or down	Motor
Turntable	Up to open, down to close	Motor

### 3-5 Safety related components

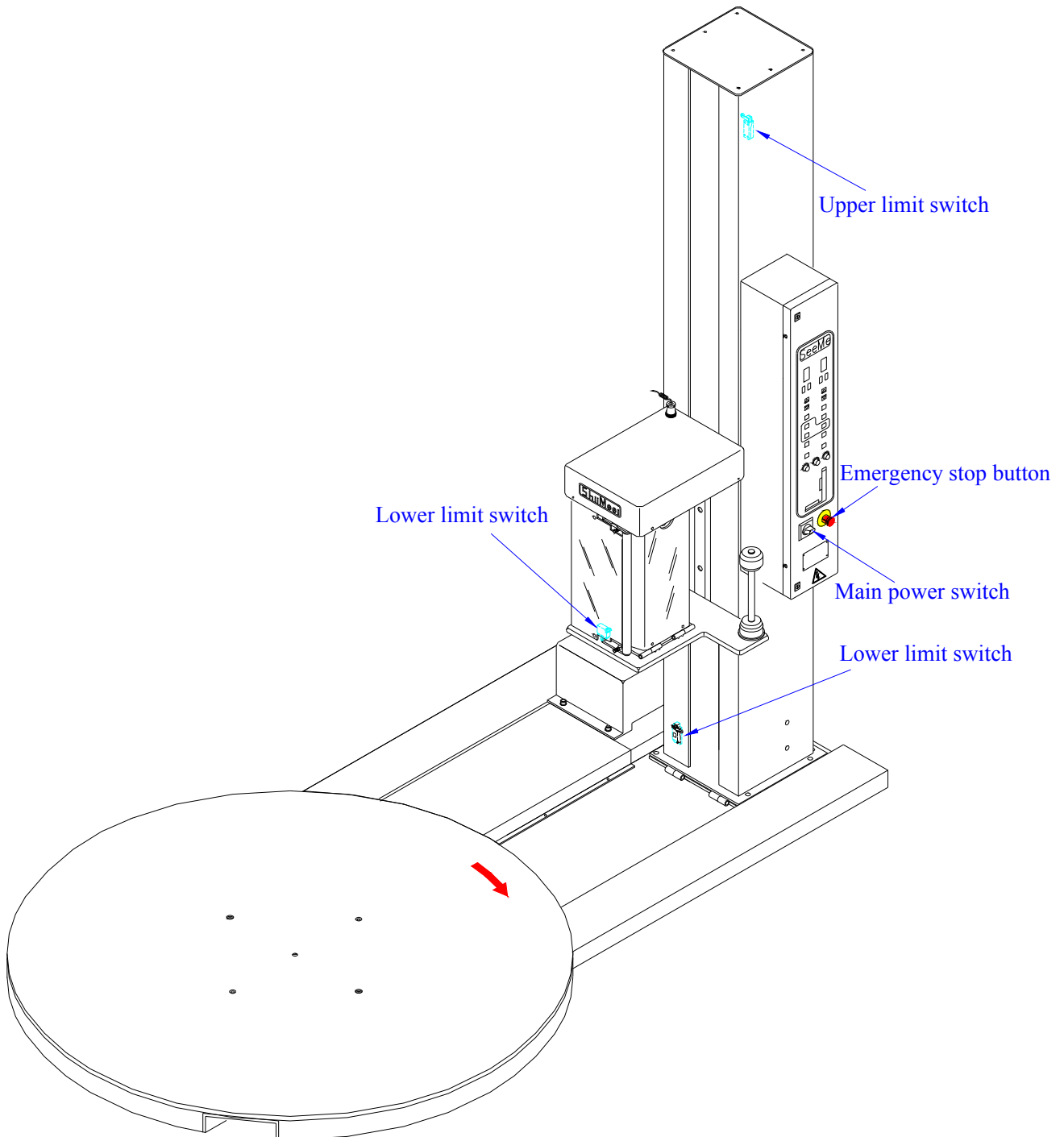

## 4 Installation of the machine

### 4-1 Setting the machine and choosing base

1. The site for the machine should provide the conditions essential for precision installation,
2. If the machine is placed on an upper floor, it shall ensure that the floor has adequate strength for this machine.
3. A clear area must be provided along the rear face of the machine in accordance with the diagram forward in page 2 and it is essential for efficient maintenance and assembly.

### 4-2 Packing and Unpacking

1. In general, the machine was packed with carton and pallet. The processes are as follows:
2. Please refer to machine weight in page 2 to arrange handling equipment.
3. Before unpacking always keep the mark **↑** (or “up” arrow sign) upward and keep the packing away from impact for preventing any damage on the machine.
4. Remove top portion first. Then, remove the side portions.
5. Do not damage any components inside the carton.
6. About the packing procedures, please refer to the following illustration diagrams.
7. The unpacking procedure is the reversal of packing.



1. Firstly, fix the side portion. Reserve the gap between the column and the side portion for minimum 1 cm.
2. Fix the opposite side portion.



3. Fix the supporting frames.



4. Put and fix the side carton.



5. Fold the carton to cover the top and fix by nails with plastic washers.



6. Tighten the pack with steel strips.

### 4-3 Handling and Transportation

#### **Caution!**

**The machine shall be moved by persons who are qualified. Persons exclude the operators are not allowed to stay in the work place during transporting the machine.**

1. Please refer to machine specifications to arrange handling equipment. Be sure to use capable fork-lifter to lift machine.
2. The handling and transportation shall be carried out by qualified persons.
3. Forklift that used in handling the machine shall be operated by a qualified driver.
4. Before handling, make sure all movable parts are secured in their positions and all movable accessories should be removed from machine.
5. During handling, people are strictly prohibited from entering into the path of machine movement.
6. While transportation, keep attention to the balance of machine.
7. As the fork position, please refer to the diagrams shown below.



**Fig.1**



**Fig.2**

For machine pack transportation:

1. If the machine pack is transported from the narrow side, the fork length used on the forklift should be more than 2.2 m. (as shown in the illustration diagram Fig.1)
2. If the machine pack is transported from the wide side, the fork length used on the forklift should be more than 1 m. (as shown in the illustration diagram Fig.2)



**Fig.3**



**Fig.4**

For machine handling, please do it according to that shown in the illustration diagram Fig.3 and Fig.4



#### 4-4 Installation of machine



1. First fix an eye end screw on the top of Pillar.



2. Hook the chain on the eye end.



3. Attached the chain or steel cable on a fork lift. Get five M5X25 screws ready from the tool box.



4. Rise the fork up around 2m high,



5. Slowly move back the fork lift until the Pillar is up around 80 degree to the ground.



6. Push the Pillar until it is right up.



7. Use 5 M 12x25 Socket head screws with washers to tight up the Pillar on the base. Be sure those 5 screws have been fastened securely.

#### 4-5 Assemble the Pre-stretch Unit



Place the M12 x 55 bolts into place and hook the pre-stretch unit onto the film seat.



Make sure bolts are tightened onto the film seat to secure the pre-stretch unit and ensure safe operation.



Connect XP3 onto XS3 and tighten.

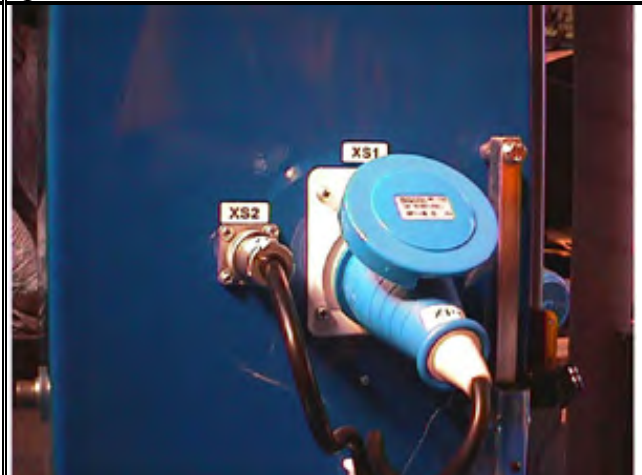

Connect XP1 onto XS1.



Extend connection point XP4 through the pre-stretch unit.



Connect XP4 onto XS4.

# 5 Control Panel

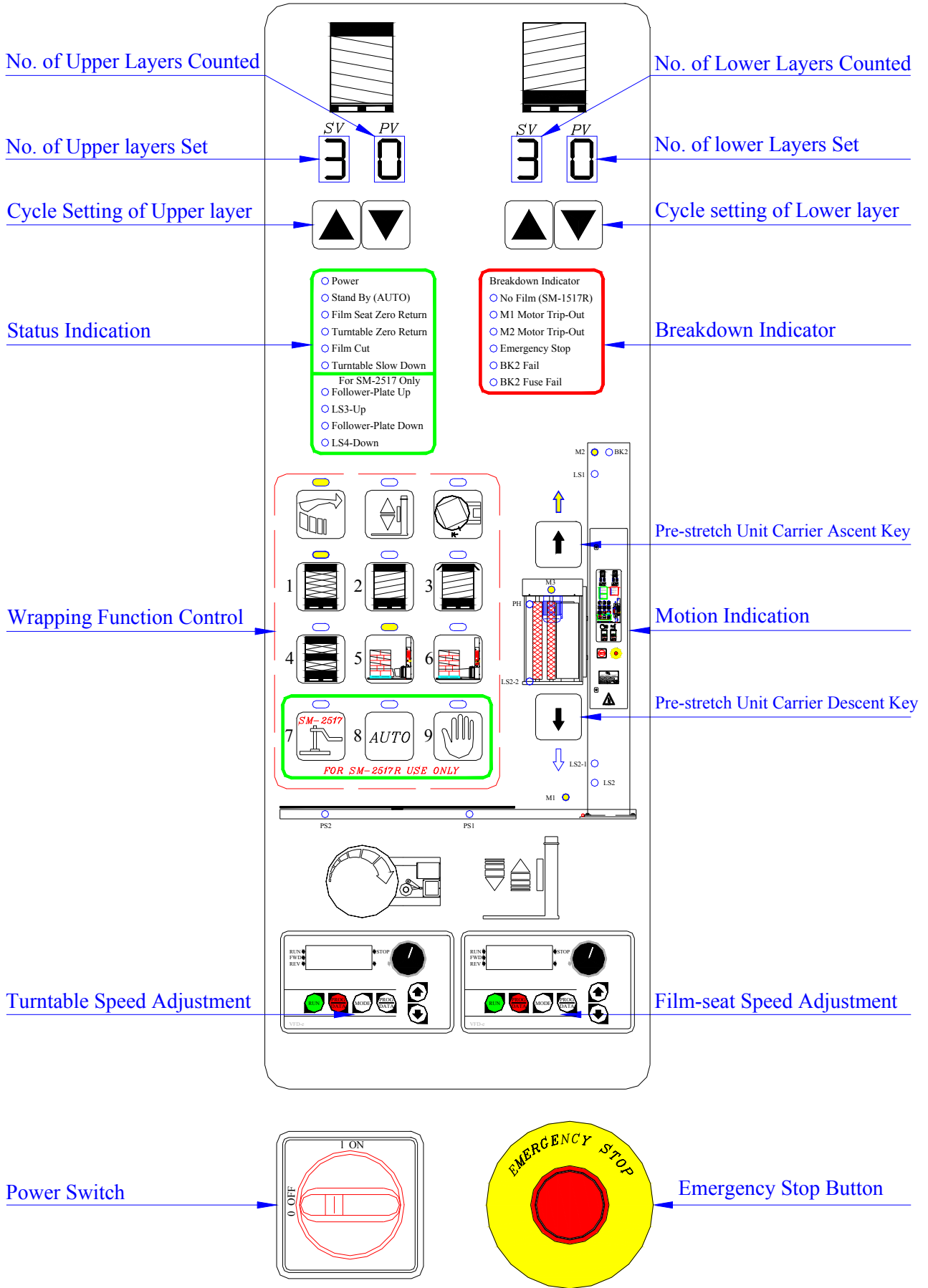



## 5-1 Description of Key pad's function on the control panel

### **No. of Upper Layers Counted:**

Displays the number of completed upper layer wrapping cycles. Screen should be blank prior to start of wrapping cycle. When wrapping cycle begins, for each completed upper layer wrapping cycle the number increases by 1. When number of upper layers counted reaches the number of upper layers set, the film-seat will start descending.

### **No. of Upper Layers Set:**

Displays the number of wrapping cycles set for the upper layer.

### **Cycle Setting of Upper Layer:**

Sets the number of upper layer wrapping cycles. Press “▲” once increases wrapping cycle by 1 and press “▼” decreases wrapping cycle by 1. Wrapping cycle can be set to 9 as maximum, however usually is set between 2-5 depending on different needs. Please note that wrapping cycle can not be set to 0, as to lengthen the life span of the elevation motor.

### **No. of Lower Layers Counted:**

Displays the number of completed lower layer wrapping cycles. Screen should be blank prior to start of wrapping cycle. When wrapping cycle begins, for each completed lower layer wrapping cycle the number increases by 1. When number of lower layers counted reaches the number of lower layers set, the film-seat will start ascending.

### **No. of Lower Layers Set:**

Displays the number of wrapping cycles set for the lower layer.

### **Cycle Setting of Lower Layer:**

Sets the number of lower layer wrapping cycles. Press “▲” once increases wrapping cycle by 1 and press “▼” decreases wrapping cycle by 1. Wrapping cycle can be set to 9 as maximum, however usually is set between 2-5 depending on different needs.

### **Status Indication:**

For detail, refer section 5-3.

### **Breakdown Indication:**

For detail, refer section 5-4.

### **Wrapping Function Control:**

For detail, refer section 5-2.

**Motion Indication:**

For detail, refer section 5-5.

**Turntable Speed Adjuster:**

Turntable speed can be adjusted between 0-13rpm . This function should be used in conjunction with the Film-seat Speed Adjuster, refer to Film-seat Speed Adjuster section for more detail.

**Film-seat Speed Adjuster:**

Film-seat speed can be adjusted between 0~3m /min, either quicken or slower film -seat elevation speed for desired level of film overlap. When wrapping a test package, adjust turntable speed to maximum 13rpm and film-seat to maximum 3m/min, then when wrapping completes study the level of film overlap for further adjustment. If a higher level of film overlap is desired, slower the film-seat speed; if a lower level of film overlap is desired, slower the turntable speed.

**Power Switch:**

Main power switch with a safety device. When switch is turned "ON", the switch will jam the control panel door and prevent it from being opened to provide safety. Please note that if the control panel door is to be opened this switch must be turned "OFF", or else if the door is forced open when switch is at "ON" position, the switch will break. If the power switch is broken in such a manner, it can not be replaced free of charge even if still under warranty.

**Emergency Stop Button:**

In case of emergency, press this button to stop the operation of the machine and the power will automatically be turned off. Pull this button to deactivate the emergency stop.

**Pre-stretch Unit Ascent Key:**





This key is used to manually control the pre-stretch unit to ascent while the machine has stopped. Press this key; the pre-stretch unit will go up. Release it, the pre-stretch unit will stop immediately.

**Pre-stretch Unit Descent Key:**

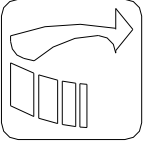
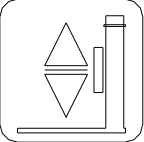
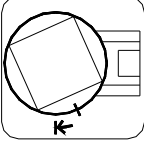
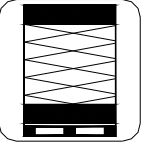
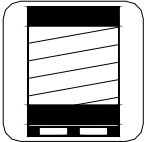
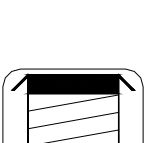
This key is used to manually control the pre-stretch unit to descent while the machine has stopped. Press this key; the pre-stretch unit will go down. Release it; the pre-stretch unit will stop immediately.

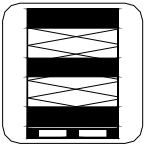
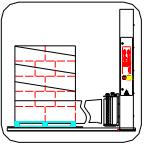
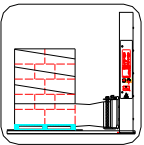
## 5-2 Wrapping Function Control

	<p>『 <b>Turntable Start</b> 』 :</p> <p>Starts the turntable rotation, motor will stop automatically when wrapping is completed.</p>
	<p>『 <b>Film-Seat Pause Button</b> 』 :</p> <p>When wrapping a particular section of the package that needs extra overlapping of film to give strength, press and hold this button for the film-seat to pause at the desired section of overlapping. When the operator is satisfied with the amount of overlapping, release this button and the film-seat will continue its ascending/descending.</p>
	<p>『 <b>Turntable and Film-seat Zero-return Button</b> 』 :</p> <p>This button has two functions:</p> <p><b>1:</b> It can be used to determine the height of package in case of malfunctioning of the electronic eye. When electronic eye malfunctions, the film-seat can not sense the height of the package and will continue to ascend, in which case by pressing this button the film-seat will cease ascending and start counting number of upper layer wrapping cycles. Also press this button if the film wrapping reaches a particular height of the package and further more wrapping above is not desired.</p> <p><b>2:</b> If the emergency button is activated during wrapping, the turntable and the film-seat will not be stopped at the starting position. Therefore in order for both the turntable and the film-seat to return to their starting position, press this button once for turntable to return to starting position and press again for film-seat to return to starting position.</p>
	<p>『 <b>Standard Wrapping</b> 』 :</p> <p>Film starts wrapping from the bottom of the package to the top, and once from top back to bottom.</p>
	<p>『 <b>Single Layer Wrapping</b> 』 :</p> <p>Film wraps once from bottom to top and stops when turntable comes to a halt. Film set then automatically descends down to starting point.</p>
	<p>『 <b>Water Proof Wrapping</b> 』 :</p> <p>Film wraps from bottom to top and then comes to a halt at approximately 10cm~15cm below the top of the package, then a sheet of waterproofing film or plastic should be manually placed on top of the package. Press the Turntable Start button once more to restart the wrapping process, at which the film will start wrapping from top back to bottom.</p>

	<p>『 <b>Midpoint Strengthen Wrapping</b> 』 :</p> <p>Film wraps from bottom to top and completes the upper layer wrapping cycle. When returning from top back to bottom, film set will pause at the midpoint of the package to complete 2 wrapping cycles and then back to bottom to complete wrapping.</p>
	<p>『 <b>Auto cut option</b> 』 :</p> <p>To choose the auto cut option.</p>
	<p>『 <b>Non-auto cut option</b> 』 :</p> <p>To choose the non-auto cut option.</p>
<p><b>For SM-2517 &amp; SM-2517R Use only</b></p>	
	<p>『 <b>Follower-Plate Fall Down Button</b> 』 :</p> <p>To lower the follower-plate, used in conjunction with the 『 Auto 』 &amp; 『 Manual 』 buttons. When set at 『 Auto 』, press this button to lower follower-plate onto package until tight, after which the follower-plate stops lowering and turntable rotation starts. If set at 『 Manual 』, press this button to lower follower-plate to stop lowering follower-plate. There is need to press the Turntable 『 Start 』 button to start turntable rotation when using 『 Manual 』 function..</p>
	<p>『 <b>Auto</b> 』 Wrapping Modes Setting Key:</p> <p>When this function is set the button will light up. Press the “Follower -plate Down” button when this function is activated, the follower-plate will automatically lower onto package until tight and turntable rotation will start. When wrapping cycle is completed, the follower-plate will lift up again. No need to press any other button.</p>
	<p>『 <b>Manual</b> 』 Wrapping Modes Setting:</p> <p>When this function is set, press the “Follower-plate Down” button to lower the follower-plate and limit switch LS4 is touched to stop lowering. The turntable will not start automatically, therefore press “Turntable Start” button to start turntable rotation.</p>

### 5-3 Status Indication

- Power
- Stand By (AUTO)
- Film Seat Zero Return
- Turntable Zero Return
- Film Cut
- Turntable Slow Down

For SM-2517 Only

- Follower-Plate Up
- LS3-Up
- Follower-Plate Down
- LS4-Down

#### Power Pilot

When LED light is on, the power is at the “ON” status; when LED light is off, the power is at the “OFF” status.

#### Stand By (AUTO)

The machine is in standby status.

#### Film Seat Zero Return:

The film carrier is descending back to the Zero point.

#### Turntable Zero Return:

The turntable is rotating back to the Zero point.

#### Film Cut

The machine is breaking the film,

#### Turntable Slow Down

The turntable is slowing down,

#### Follower-Plate Up

The Follower-Plate is ascending,

#### LS3-Up

LS3 is the (Zero point) limit switch: If this light on indicates the “Follower-Plate” has ascended back to the Zero Point. If the “Follower-Plate” has not back to the Zero Point the machine will not be operated.

○Follower-Plate Down

The Follower-Plate is descending,

○LS4-Down

If this light on, indicates the “Follower-Plate” has clamped the package tight and the “Follower-Plate” will be stopped. If this light has not on, the machine will not be operated.

## 5-4 Breakdown Indication

### Breakdown Indicator

- No Film (SM-1517R)
- M1 Motor Trip-Out
- M2 Motor Trip-Out
- Emergency Stop
- BK2 Fail
- BK2 Fuse Fail

#### No Film:

Indicates no film; only SM-1517R has this function.

#### M1 Motor Trip-Out:

The M1 motor is overloaded and its breaker jumped.

#### M2 Motor Trip-Out:

The M2 motor is overloaded and its breaker jumped.

#### Emergency Stop:

Emergency Stop Indicator, When the LED light is on, the emergency stop button is currently being activated.

#### BK2 Fail:

The BK2 electrical Break has failed.

#### Bk2 Fuse Fail:

The fuse of the BK2 electrical Break has failed.

## 5-5 Motion Indication

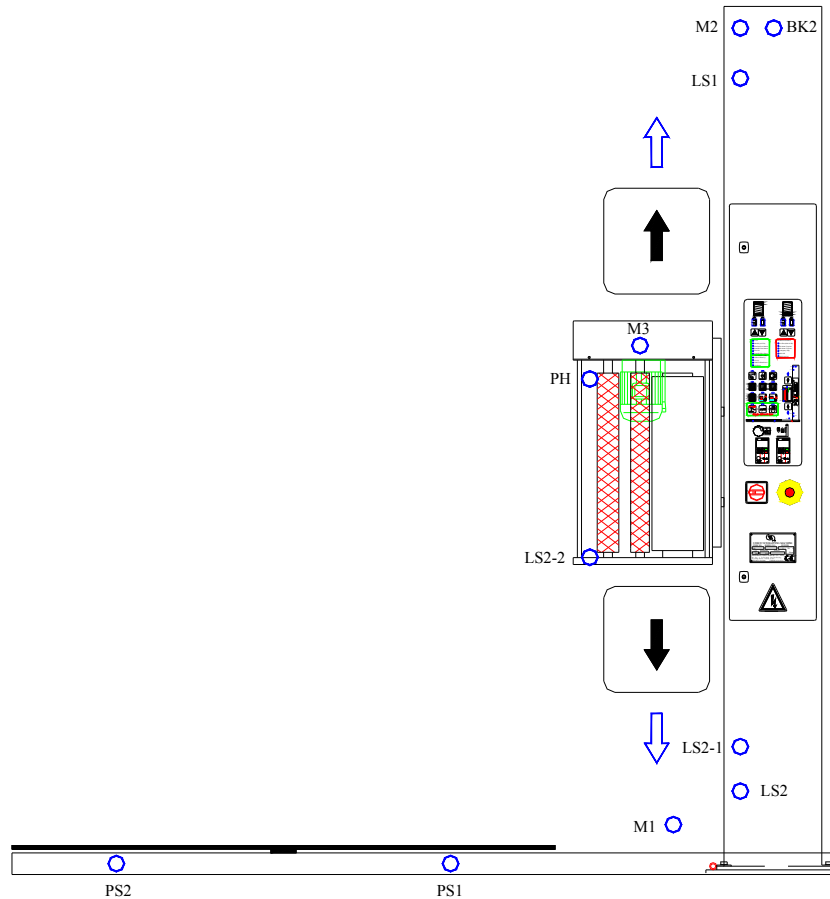

### M2 Motor Ascending and Descending Indicator

If this LED light is on indicates the M2 motor is in operation, the pre-Stretch Unit is ascending or descending.

### LS1 Upper Limit Safety Switch Indicator

If this LED light is on, indicates the package has over the packing height limit of this machine or the PH (height detecting optical sensor) has failed; please check if the package height has over the limit or PH sensor has failed.

### M3 Pre-Stretch Unit Motor Indicator

When the turntable is starting to rotate and the film pulls the free roller, this light will be on and the film will start to be sent out from the Pre-Stretch Unit; if this LED light is not on, the film will not be sent out from the Pre-Stretch Unit.

### PH Height Detecting Optical Sensor Indicator

When PH has detected the package, this LED light will not be on. Once the film carrier ascend and the PH sensor can not detect the package, this light will be on and the film carrier stop.

### LS2-2 Pre-Stretch Unit Safety Switch Indicator

This switch is parallel link with the LS2 (lower Limit Safety Switch). When this LED light is on



indicates the Pre-Stretch Unit has descended to the lower limit or the Pre-Stretch Unit has pressed any object and the turntable will be stopped.

#### LS2-1 Lower Limit Switch Indicator

When this LED light is on indicates the Pre-Stretch Unit has descended to the bottom position and the Pre-Stretch Unit will stop to descend.

#### LS2 Lower Limit Safety Switch Indicator

This switch is parallel link with the LS2-2 (Pre-Stretch Unit Safety Switch). When this LED light is on indicates the Pre-Stretch Unit has descended and over the bottom of the machine or the LS2-1 has failed. Please check the LS2-1 switch.

#### M1 Turntable Motor Indicator

This LED light on indicates M1 (Turntable Motor) is operating and the turntable is rotating.

#### PS1 Allocation and Counter Indicator

When the turntable completes a rotation, this LED light will flash once. Therefore this indicator expresses two functions: a counter and an indication of a complete rotation.

##### Counting Function:

When the turntable completes a rotation this indicator will flash once and the counter number will be increased by one until the rotation number has reach the pre-set wrapping number. After that, although the turntable completes one rotation and this indicator will still flash once, however the counter number will not be increased.

##### Allocation Function:

When PS2 (Slow Stopping Indicator) flashes once, the turntable will start to slow down, once the PS1 indicator flashes the turntable will be stopped immediately. This indicator's light will be on to indicate the turntable has stopped at the zero point.

#### PS2 Slow Stopping Indicator

When the LED light of LS2-1 is on, once the turntable passed the PS2 switch, the light of the "PS2 Slow Stopping Indicator" will flash once and the turntable will start to be slowing down until the turntable has fully stopped.

#### ↑ Pre-Stretch Unit Ascending Indicator

This LED light on indicates the Pre-Stretch Unit is ascending.

#### ↓ Pre-Stretch Unit Descending Indicator

This LED light on indicates the Pre-Stretch Unit is descending.

## 6 Film Loading (For safety please switch off main power when loading film.)



1. Pull out approx. 60cm of film in counter-clock direction.

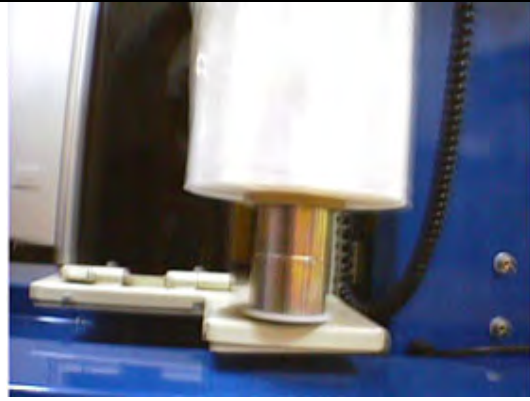

2. Place film into film seat.



3. Pull down film seat cover lock.



4. Open film seat cover.



5. Pull out film between film seat cover and film seat rollers.



6. Have at least 20-30cm of film out through between film seat cover and rollers.



7. Close film seat cover and switch on power to start operation.

## 7 Film Tension Adjust

The pre-stretch unit has a set pre-stretch percentage of 240% (can not be changed) which is called the First Stage Pre-stretch, therefore there is no pre-stretch setting device on the control panel. The pre-stretch percentage can be slightly adjusted to a maximum of 320%, which is called the Second Stage Pre-stretch, and its adjusting method is shown below:



There are 2 sets of nuts and bolts located on the top and bottom of the free roller and is used to

adjust pre-stretch ratio.



Pull away the free roller and 2 springs can be seen attached to the 2 sets of nuts and bolts.



Slightly tighten the nuts onto the bolts to pull on the springs in order to increase pre-stretch ratio.

**Warning:** Do not pull on free roller while pre-stretch unit in operation, as not to cause film jamming into rollers.

## 8 Operation Procedure

1. Turn power switch to "ON" position.



2. Set number of upper and lower layer cycles.



3. Set film tension.



4. Set film-seat speed.



5. Pull out a small length of film and tie to pallet or to hook on turntable.



6. Press start button.



7. To continue wrapping, just repeat steps 5 and 6.

## 9 Maintenance

### 9-1 Installing and removing turntable

Firstly remove the 4 fixing screws from the turntable, then screw on the 2 lifting devices onto turntable perpendicularly.



Use one of the forklift's forks to penetrate the lifting devices.

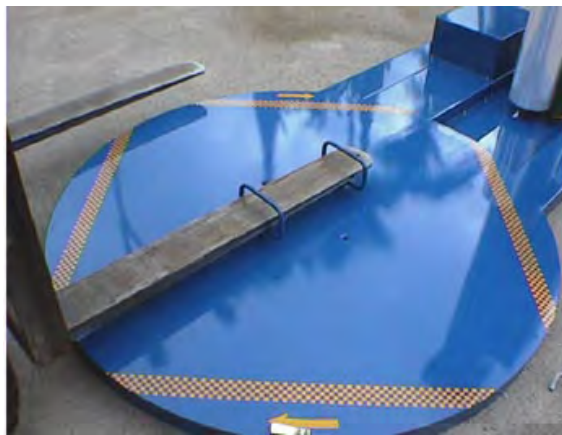

Lift the turntable up and away from the machine to begin maintenance and service.





## 9-2 Adjusting tightness of turntable chain



In case of turntable chain becoming loose.

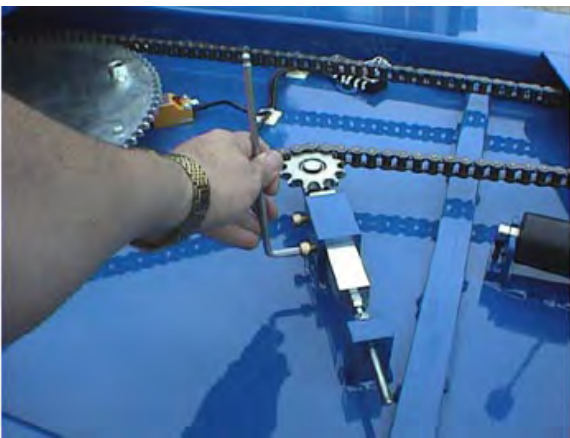

1. Use a 6mm L shape spanner, in counter-clockwise direction, loosen the two M8 bolts.

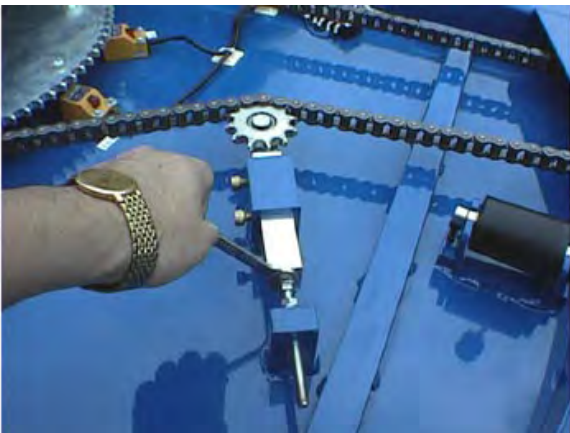

2. Use a 14mm open spanner, in clockwise direction, turn the M14 nut to tighten the chain.
3. Similar to step 1, use a 6mm L shape spanner to tighten the two M8 bolts in clockwise direction.
4. Put little amount of grease oil on the chain and the six turntable supporting wheels.

## 10 Electrical

### 10-1 Part list of electrical components

Item designation	Description & function	Manufacture	Type	Technical data	Complies with the following standards	Marking of conformity granted
SP1 Switching	power supply, supply dc power to controller	Mean Well	PD-25A	Ue=240VAC OUT1:DC5V 2.1A OUT2:DC12V1.2A	EN61000-4-5,EN60950	CE,TUV
SP2 Switching	power supply, supply dc power to sps1	Mean Well	NES-15-24	Ue=240VAC OUT:DC 24V 1A	EN60950,EN61000-4-5	CE
SP3 Switching	power supply, supply dc power to brake	Mean Well	PS-65-24	Ue=240VAC OUT:DC 24V 2.7A	EN60950,EN61000-4-5	CE
KS-050201-MB Controller		Kai Shun	KS-050201-MB	DC-5V 6MHZ	EN61000-4-5 ENV50204	CE
KS-050202-KEY	Key board pcb	Kai Shun	KS-050202-KEY	DC-5V	EN61000-4-5 ENV50204	CE
KS-050203-TB	Terminal block pcb	Kai Shun	KS-050203-TB	DC-5V,12V,24V	EN61000-4-5 ENV50204	CE
MPSW1 Power	switch	ABB	OT25E3	Ue=750VAC Ith=32A AC-23A=20A	EN60204 IEC 947/1,3 IEC60947	CE
LF	Line filter	Hi & Lo	20SS4-1BC2-B	Ue=250VAC Ith=20A	E134751	CE

Item designation	Description & function	Manufacture	Type	Technical data	Complies with the following standards	Marking of conformity granted
MS Protected	inverters and motors	Iskra MS25-20		Ue=750VAC Icu=100KA Ie=20A	EN60947-2 EN60947-4-1 EN60204-1	CE,UL,CSA
IVR1 Inverter,	controls motor1's speed	DELTA VFD007E11A		Ue=115VAC 0.75KW	EN50178, EN61800-3	CE,UL
IVR2 Inverter,	controls motor2's speed	DELTA VFD004E11A		Ue=115VAC 0.40KW	EN50178, EN61800-3	CE,UL
IVR3 Inverter,	controls motor3's speed	DELTA VFD004E11A		Ue=115VAC 0.40KW	EN50178, EN61800-3	CE,UL
FAN Heat	sink	PROFANTEC	P1082HST	Ue=115VAC 0.14A	EN 61000-3-2 IEC 801-4	CE,UL
E-STOP Em	ergency stop	T.E.	ZA5BT4/ 10	Ue=400VAC Ith=10A	EN60947-1,EN60947-5-1	CE,UL,CSA
F1	Fuse, Protected the cutter of solenoid	DEMEX FM04L-B/1A		Ue=250V Ith=10A FUSE=1A	CE 947.3	CE,UL
F2	Fuse, Protected the cutter of solenoid	DEMEX FM04L-B/1A		Ue=250V Ith=10A FUSE=1A	CE 947.3	CE,UL
F3	Fuse, Input ac power to switching power sp1,sp2	DEMEX FM04L-B/3A		Ue=250V Ith=10A FUSE=3A	CE 947.3	CE,UL



Item designation	Description & function	Manufacture	Type	Technical data	Complies with the following standards	Marking of conformity granted
F4	Fuse, Input ac power to switching power sp1,sp2	DEMEX FM04	L-B/3A	Ue=250V Ith=10A FUUSE=3A	CE 947.3	CE,UL
LS1	Upper limit switch	COCA	AZ-8108	Ue=240VAC Ith=5A	EN60947-5-1 EN81 EN115	CE
LS2	Lower limit switch	COCA	AZ-8104	Ue=240VAC Ith=5A	73/23/EEC	CE
LS2-1	Lower limit switch	COCA	AZ-8104	Ue=240VAC Ith=5A	73/23/EEC	CE
LS2-2	Lower limit switch	OMRON	Z-15GQ22-B	Ue=250VAC Ith=15A	EN 60947-1	CE,VDE,UL
PS1 Proxim	ity sensor	TEND TP-SM-5N1		Ue=30VDC Iout=150mA 4m /m	EN 50082-2, EN61000-3-2	CE
PS2 Proxim	ity sensor	TEND TP-SM-5N1		Ue=30VDC Iout=150mA 4m/m	EN 50082-2, EN61000-3-2	CE
PH Photo	Sensor	FOTEK	FR-2MX	Ue=30VDC Iout=150mA	EN50082-1 IEC802-1 IEC801-3 EN55011	CE
SPS1 Proxim	ity sensor	PULSO 9914-0900		Ue=30VDC Iout=10mA IP67	EN 50010	CE

Item designation	Description & function	Manufacture	Type	Technical data	Complies with the following standards	Marking of conformity granted
M 1	Motor	ADLEE Co., Ltd.	3~AC 230VAC 0.75kW	Ue=220VAC IP55	EN60034-1 CE	
M 2	Motor	T.G.P.Co	3~AC 230VAC 0.2kW	Ue=220VAC IP54	EN60034-1 CE	
M 3	Motor	Liming Co., Ltd.	3~AC 230VAC 0.2kW	xxx		
BK2	Brake for motor2	T.G.P.Co.	SBV-063	DC24V	EN60034-1	CE
XS1 Connector		STARHL	CP00401627	Ue=380VAC Ith=16A 4 POLES IP67	CEI23-12/VII CE	
XP1 Connector		STARHL	CP11401627	Ue=380VAC Ith=16A 4 POLES IP67	CEI23-12/VII CE	
XS2 Connector		APEX CO.	PLS-207-RF			-----
XP2 Connector		APEX CO.	PLS-207-PM			-----
XS3 Connector		APEX CO.	PLS-207-RM			-----
XP3 Connector		APEX CO.	PLS-207-PF			-----
XS4 Connector		STARHL	CP01301624	Ue=220VAC Ith=16A 3 POLES IP54	CEI23-12/VII CE	

Item designation	Description & function	Manufacture	Type	Technical data	Complies with the following standards	Marking of conformity granted
XP4 Connector		STARHL	CP20301624	Ue=220VAC Ith=16A 3 POLES IP54	CEI23-12/VII CE	
TB9,TB11 Term	inal block	ENTRELEC	D4/6	UE=660VAC Ith=27A	EN60847-1 CE	
TNR1 TNR		MARCON	15G471K	Ue=300VAC 80J.		-----

## 10-2 EMC Component List

Item	Name	Specification	Refer to ckt. diagram	Approved document
1	MOTOR1	3~ 0.75KW AC220V	SM-1517R: P.1	
2	MOTOR2	3~ 0.2KW AC220V	SM-1517R: P.1	
3	MOTOR3	3~ 0.2KW AC 220V	SM-1517R: P.5	
4	LINE FILTER	20SS4-1BC2-B 20A AC250V	SM-1517R: P.1	EMC-P.1
5	INVERTER1	VFD007E-11A 0.75KW AC 115V	SM-1517R: P.1	EMC-P.2
6	INVERTER2	VFD004E-11A 0.4KW AC 115V	SM-1517R: P.1	EMC-P.2
7	INVERTER3	VFD004E-11A 0.4KW AC 115V	SM-1517R: P.5	EMC-P.2
9	SWITCHING POWER SUPPLY	PD-25A DC5V	SM-1517R: P.1	EMC-P.5
10	SWITCHING POWER SUPPLY	PS-65-24 DC24V 2.7A	SM-1517R: P.1	EMC-P.5
11	MAIN POWER SWITCH	OT25E3 Ith=32A AC 250V	SM-1517R: P.1	EMC-P.6
12	PC BOARD	KS-050201-MB	SM-1517R: P.2, P.3	EMC-P.7
13	PC BOARD	KS-050202-KEY	SM-1517R: P.2, P.3, P.4	EMC-P.7
14	PC BOARD	KS-050203-TB	SM-1517R: P.5	EMC-P.7
15	SWITCHING POWER SUPPLY	NES-15-24 DC 24V 0.7A	SM-1517R: P.5, P.7	EMC-P.8
16	FAN	3-115S 115VAC 0.07A	SM-1517R: P.1	EMC-P.10
17	PROXIMITY SENSOR	TP-SM5N1 DC30V	SM-1517R: P.7	EMC-P.11

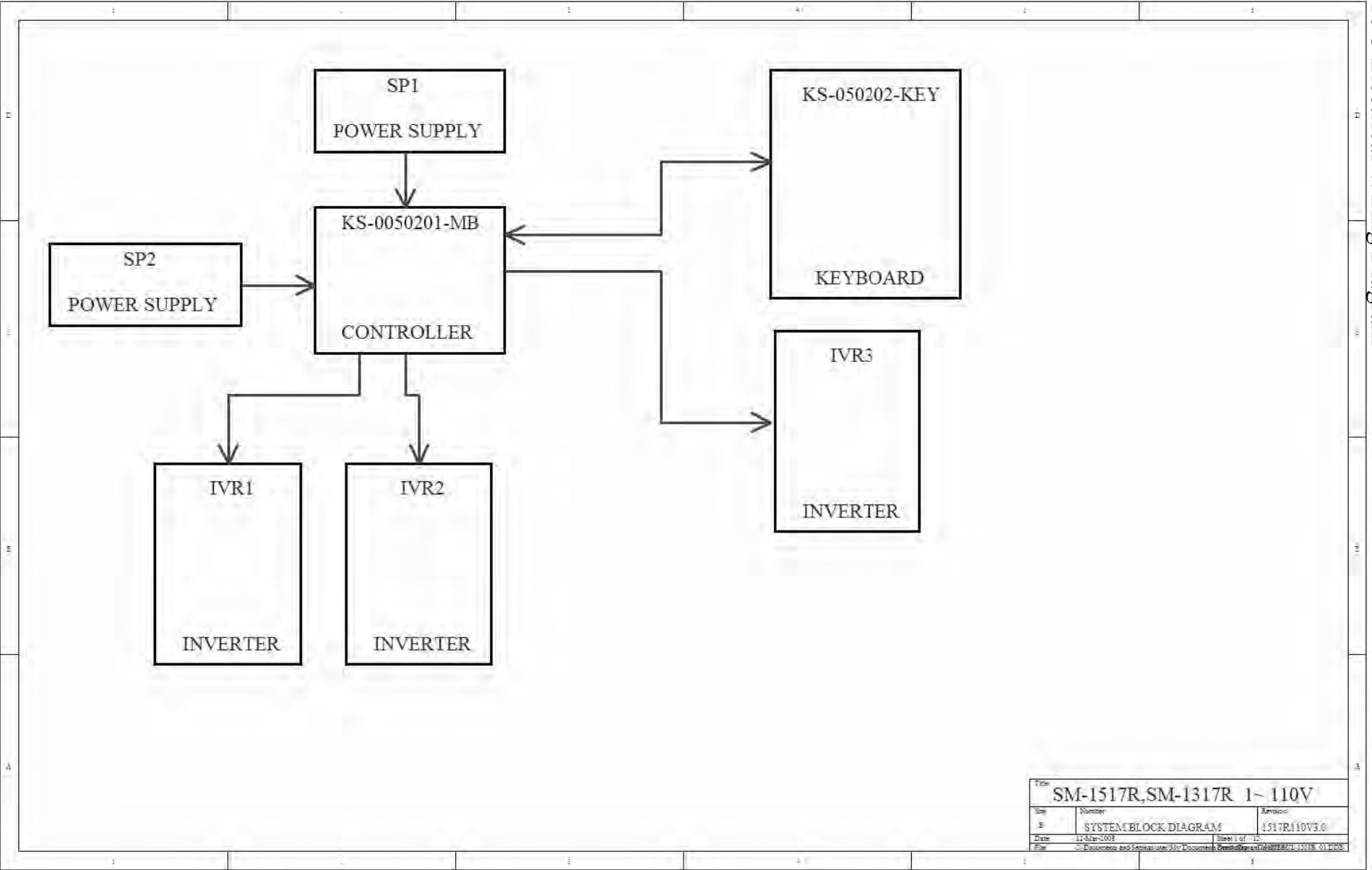

Title			SM-1517R,SM-1317R 1~110V		
Size	Number	Revision			
B	SYSTEM BLOCK DIAGRAM	1317R110V3.0			
Date	11-Sep-2009	Sheet 1 of 12			
File	C:\Documents and Settings\user\My Documents\Documents\SM-1517R_01.WDS				

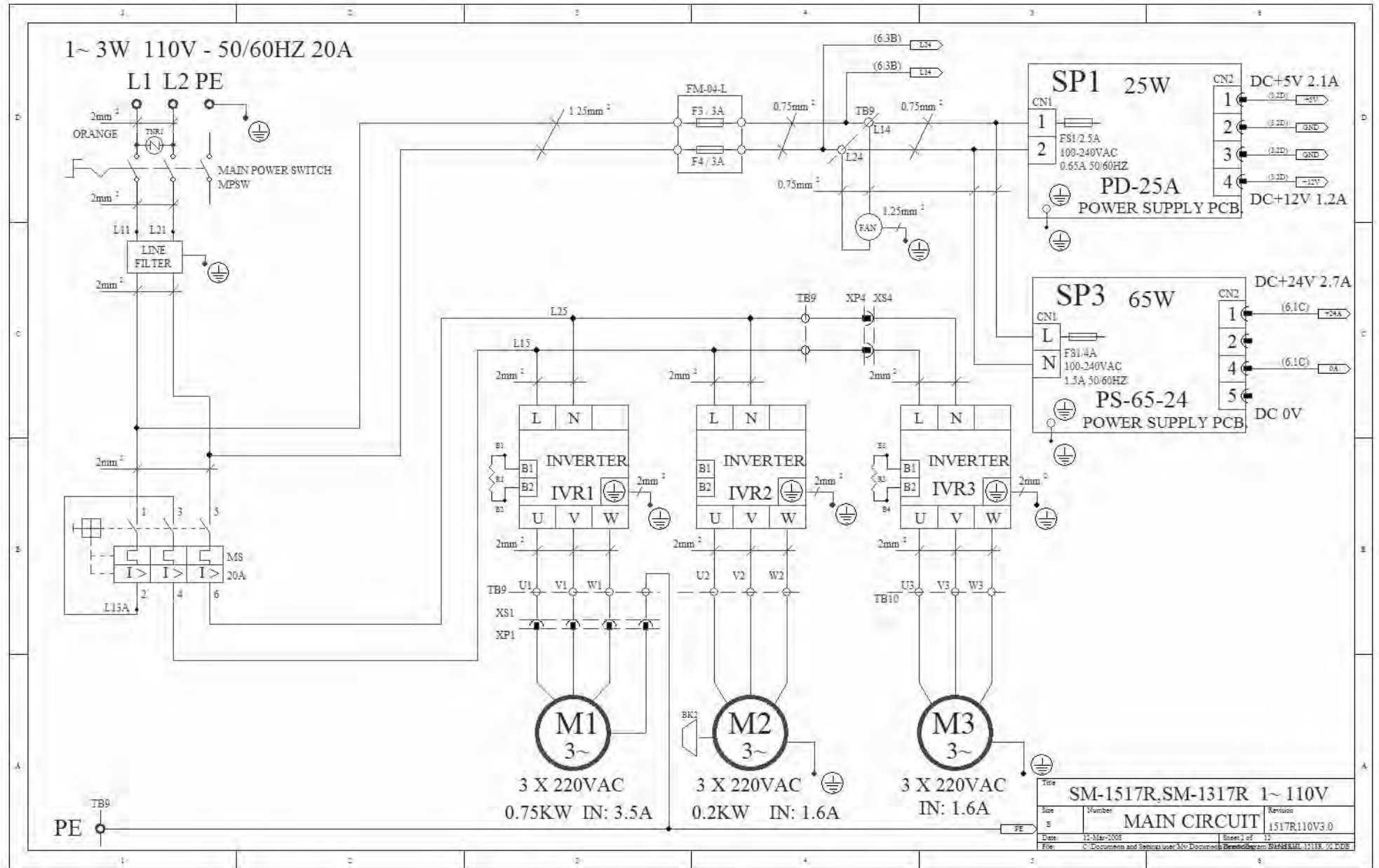

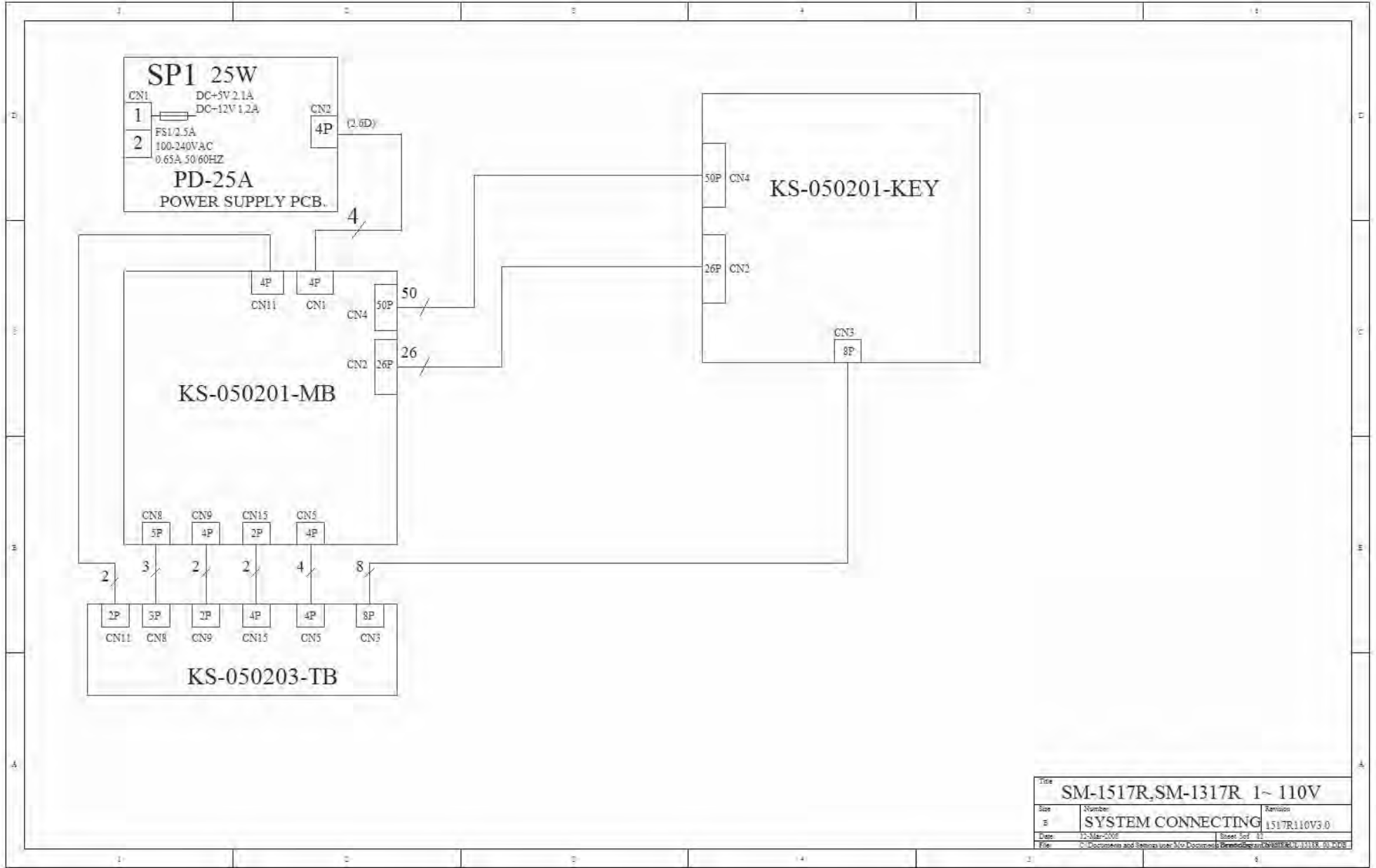

Title			SM-1517R,SM-1317R 1~110V
Size	Number	Revision	
5	SYSTEM CONNECTING	1517R110V3.0	
Date	17-Mar-2008	Sheet	3of 12
File: C:\Documents and Settings\user\My Documents\Bentley\Bentley\2\1517R_01.DWG			





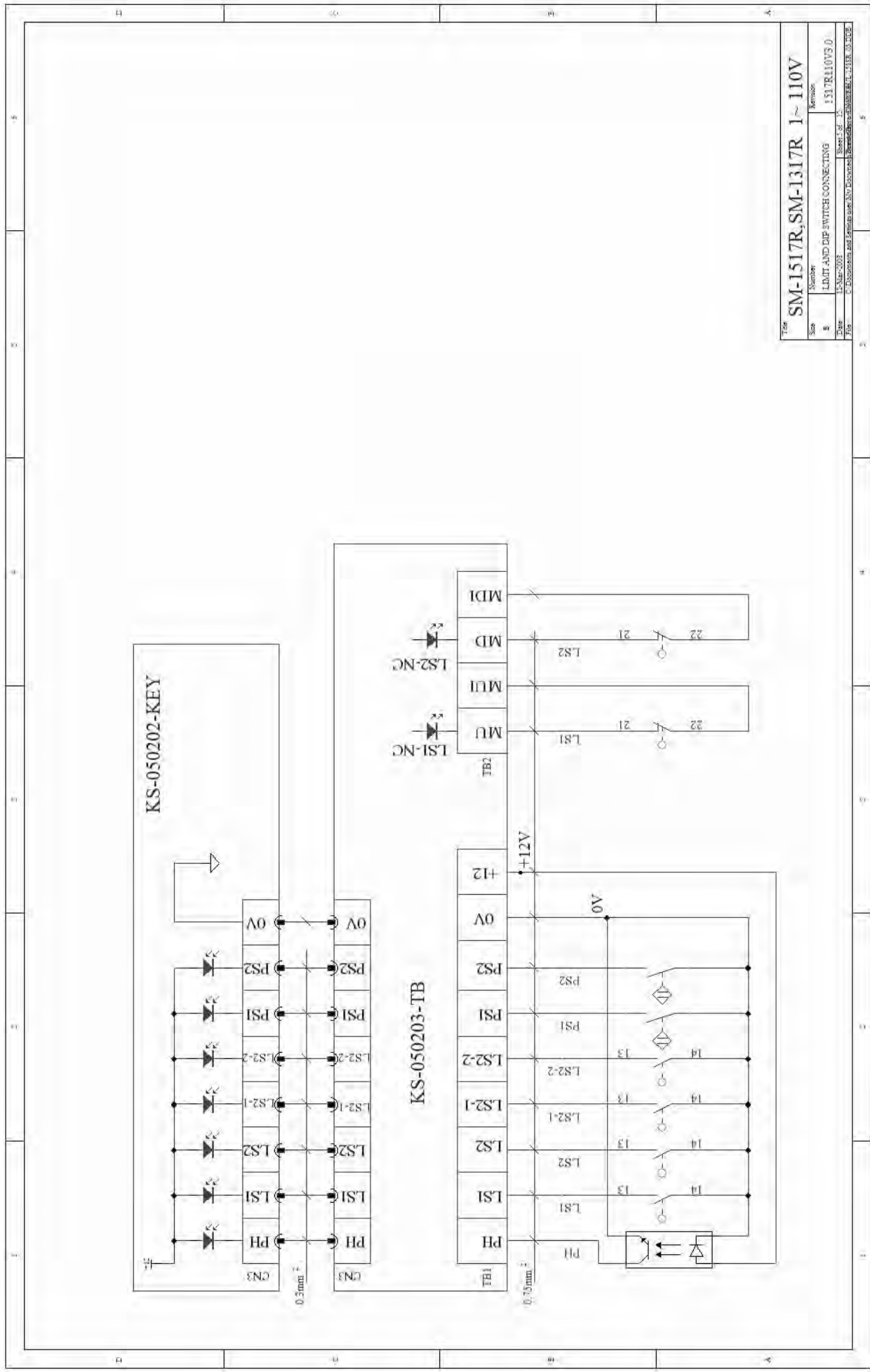

Title		SM-1517R, SM-1317R 1~110V	
Scale	Number	Revision	
1	1	1	1317R110VS D
Date	Description		Sheet 7 of 13
13Mar-2003	LIMIT AND DIP SWITCH CONNECTING		
File	C:\Dokumenten und Daten\user\307\Disciplin\Berechnungsblätter\SM-1317R_03.DWG		

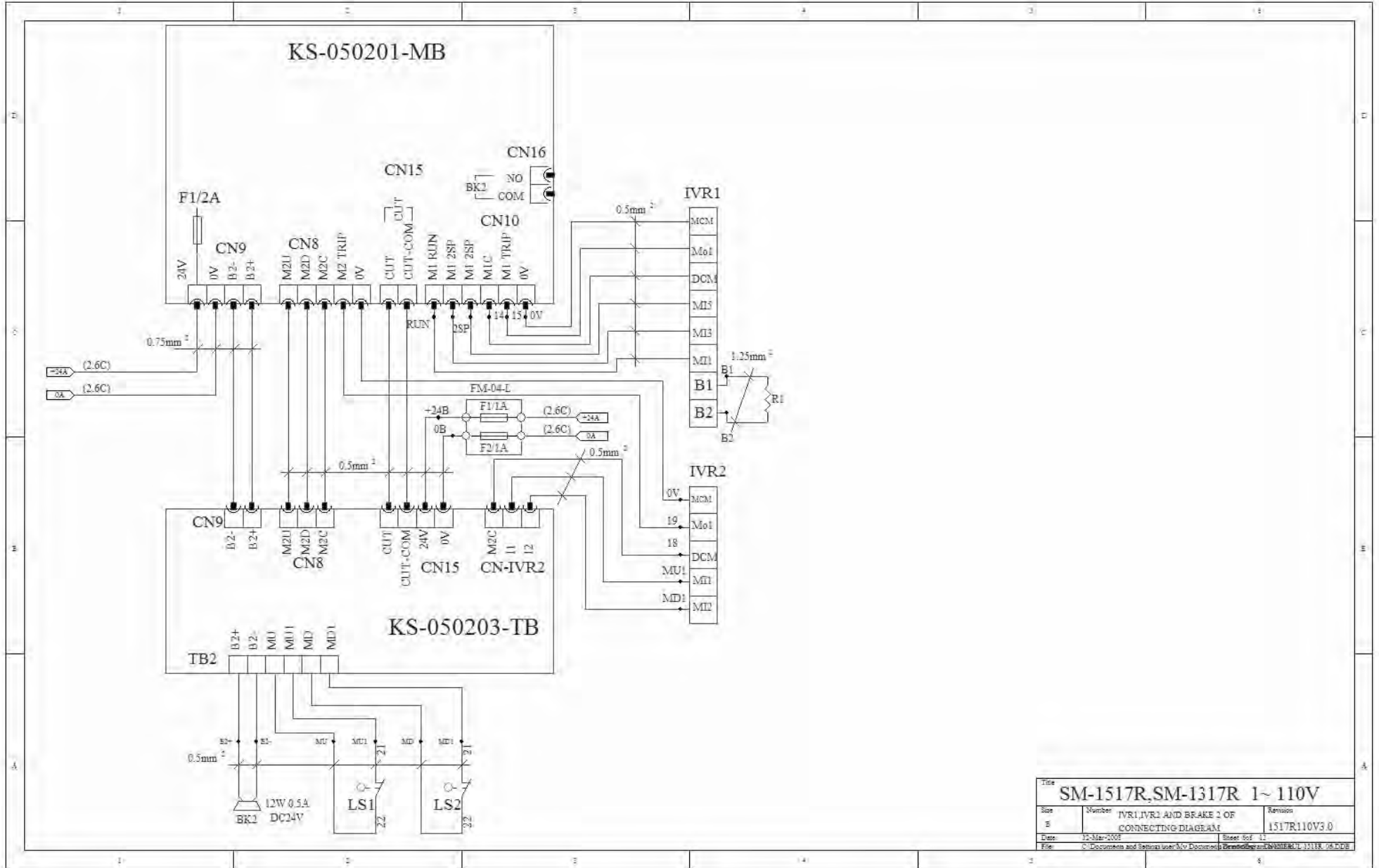

Title			SM-1517R,SM-1317R 1~110V		
Size	Number	IVR1,IVR2 AND BRAKE 2 OF		Revision	
B		CONNECTING DIAGRAM		1517R110V3.0	
Date	15-Mar-2008			Sheet	1 of 12
File	C:\Documents and Settings\user\My Documents\Bentley\Bentley\1517R_110V_04.DWG				



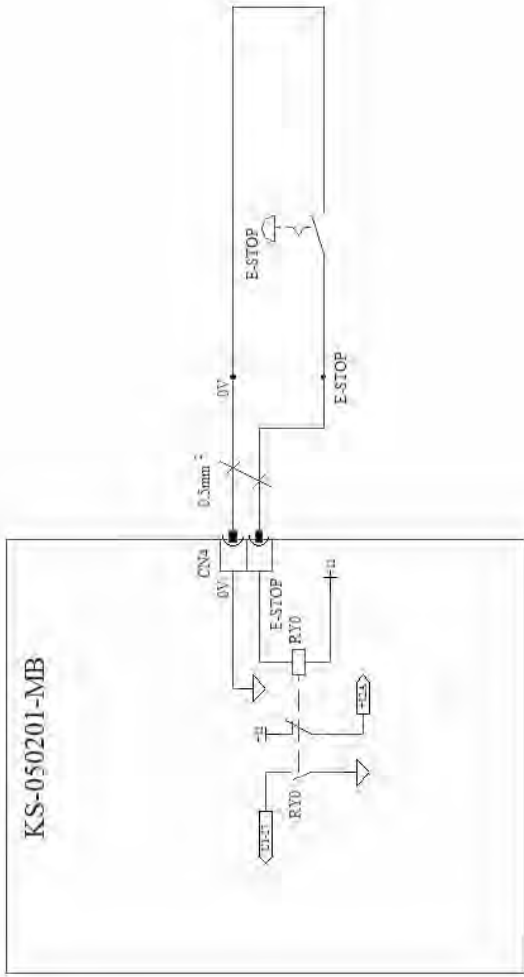

Title	SM-1517R, SM-1317R 1 ~ 110V	
Size	Number	Revision
2	E-STOP CONNECTING	1517R110V3.0
Date	15-Mar-2013	Sheet No. 1
File	C:\Documents and Settings\user\My Documents\Manuals\SM-1517R_03.DOC	

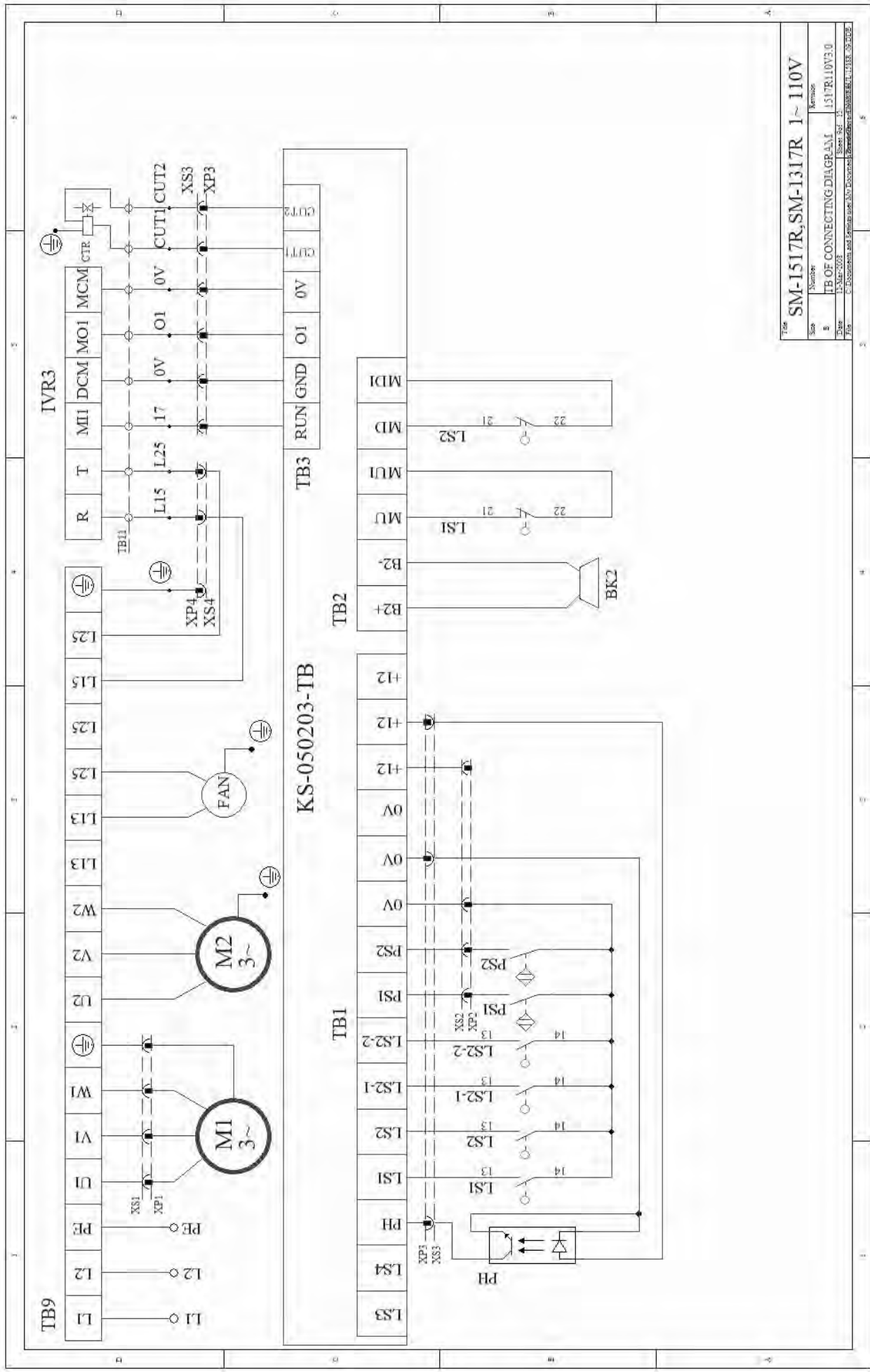

Title		SM-1517R, SM-1317R 1~110V	
Sub	Number	Remarks	
1	TB OF CONNECTING DIAGRAM	1517R110V3.0	
Date	15Mar-2008	Sheet No.	1
File		C:\Documents and Settings\user\My Documents\Documents\1517R110V3.0.DWG	

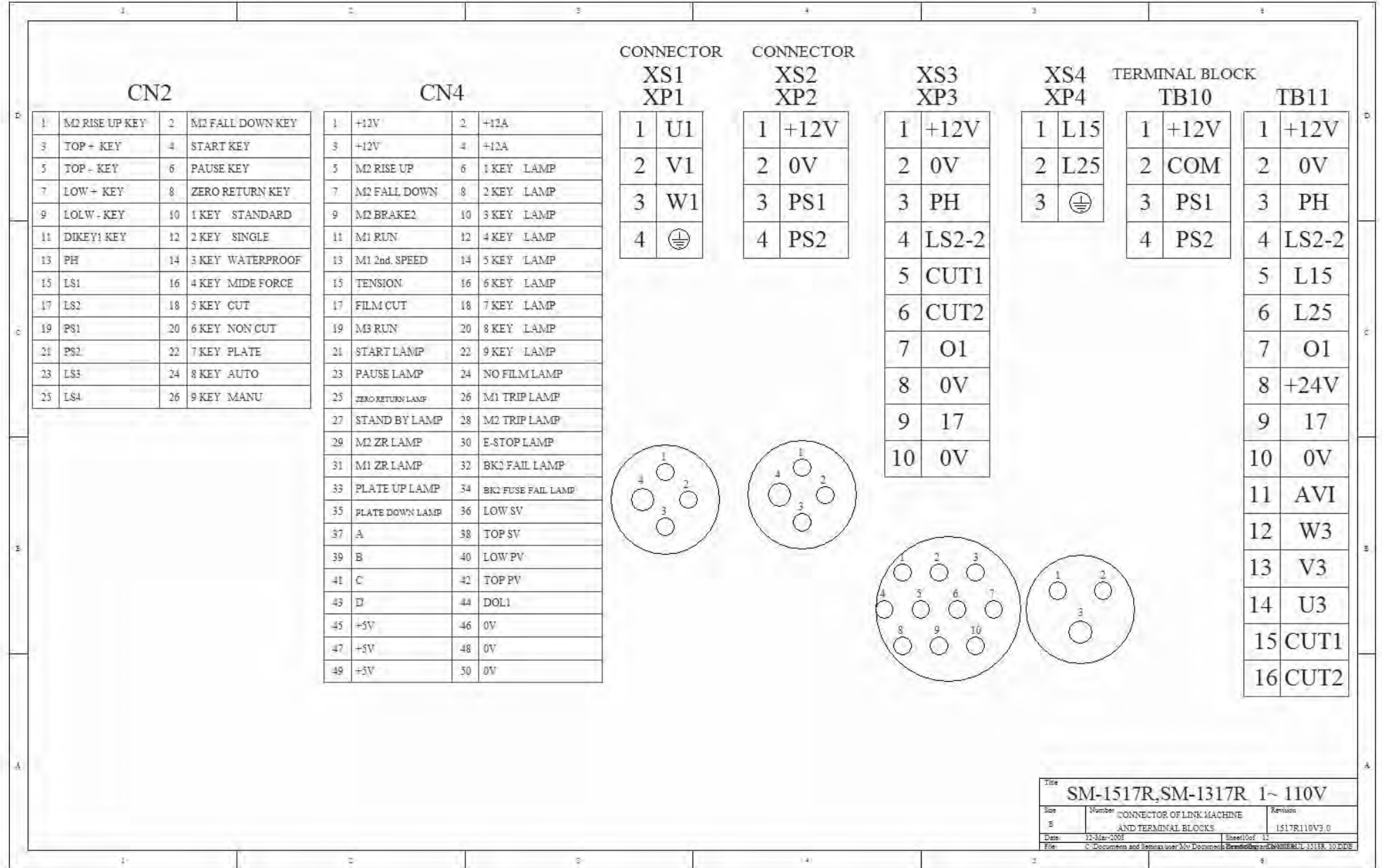

Title			
SM-1517R,SM-1317R 1~ 110V			
Size	Number	CONNECTOR OF LINK MACHINE AND TERMINAL BLOCKS	Revision
5			1517R110V3.0
Date	13-Mar-2008	Sheet/Of	12
File: C:\Documents and Settings\user\My Documents\Bentley\Bentley\1517R_110V.DWG			

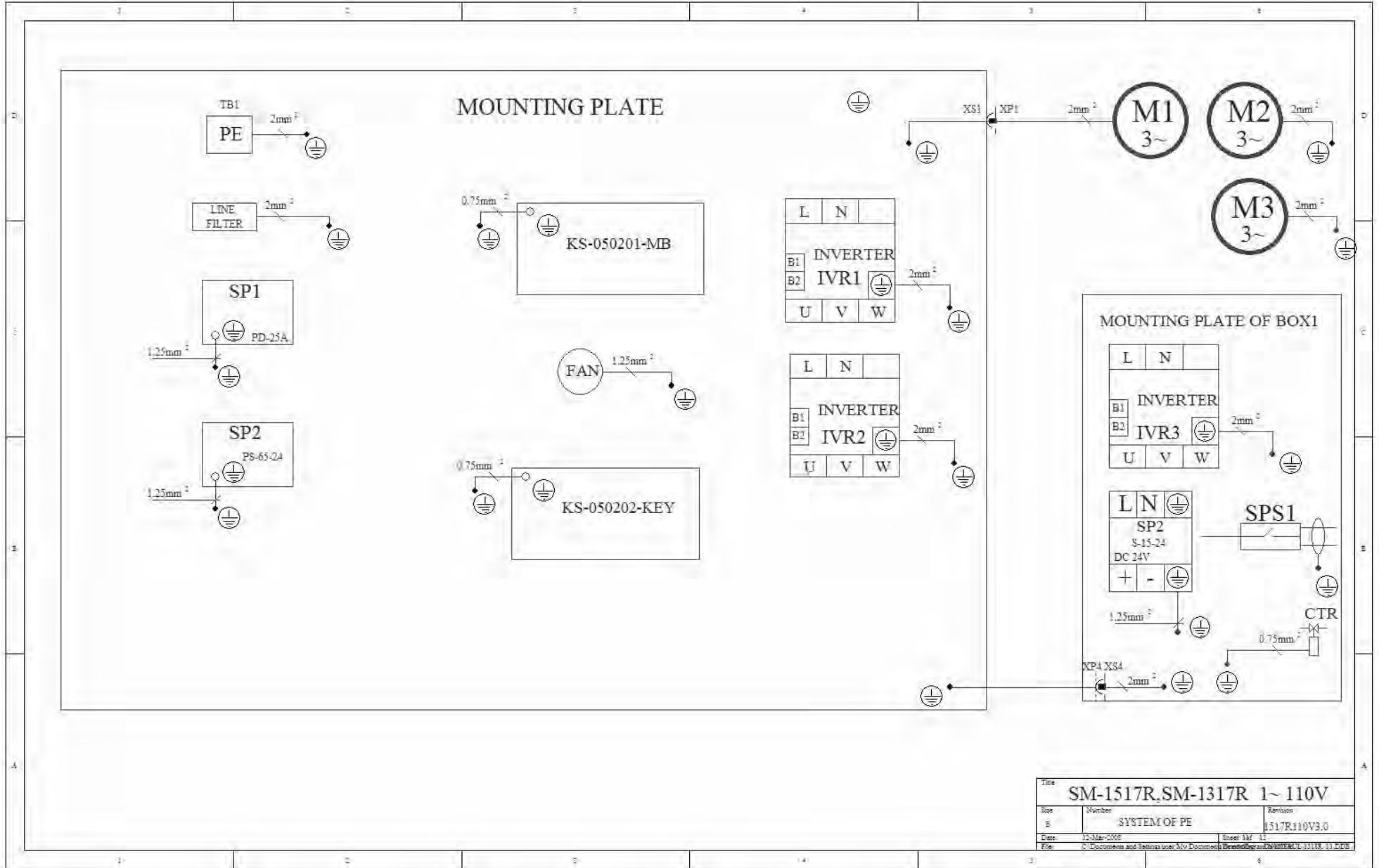

Title			SM-1517R, SM-1317R 1~110V		
Size	Number	Revision			
B	SYSTEM OF PE			1517R110V3.0	
Date	15-Mar-2008	Sheet 14/ 13			
File: C:\Documents and Settings\user\My Documents\Bentley\Bentley\211119_11.DWG					

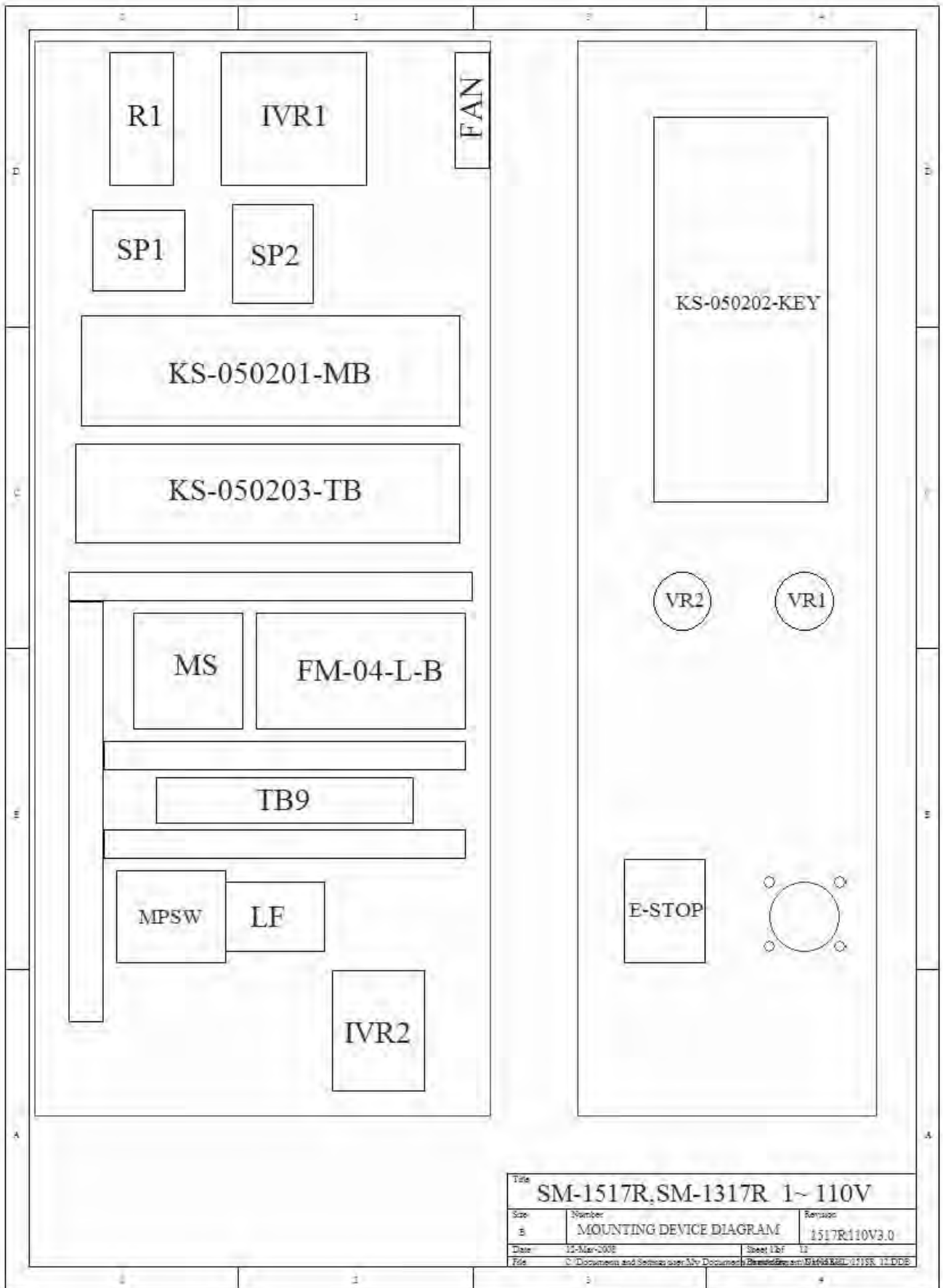

Title		
SM-1517R, SM-1317R, 1~110V		
Size	Number	Revision
B	MOUNTING DEVICE DIAGRAM	1517R:110V3.0
Date	12-Mar-2008	Sheet 1 of 12
File C:\Documents and Settings\user.Mv\Documents\20080312\1517R_110V_12.DDE		



## 11 Troubleshooting

When problem with machine occurs, please check if power input is of correct voltage and check that power supply PD-25A is outputting DC5V and DC12V and check that power supply PS-65-24 is outputting DC24V ..

### 11-1-1 Power indication hasn't lighted on

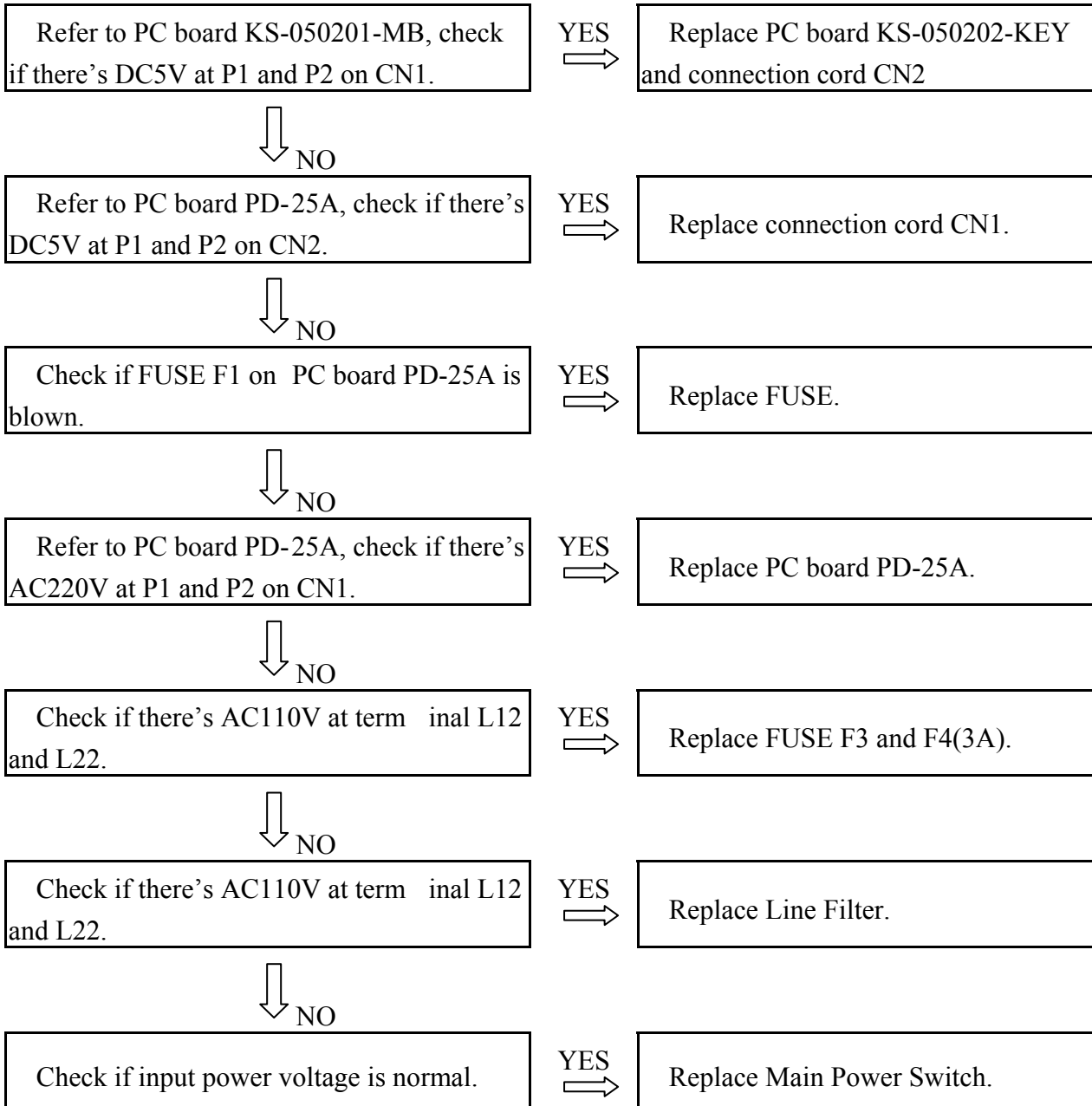

11-1-2 There isn't DC12 Volt. on power supply PD-25A

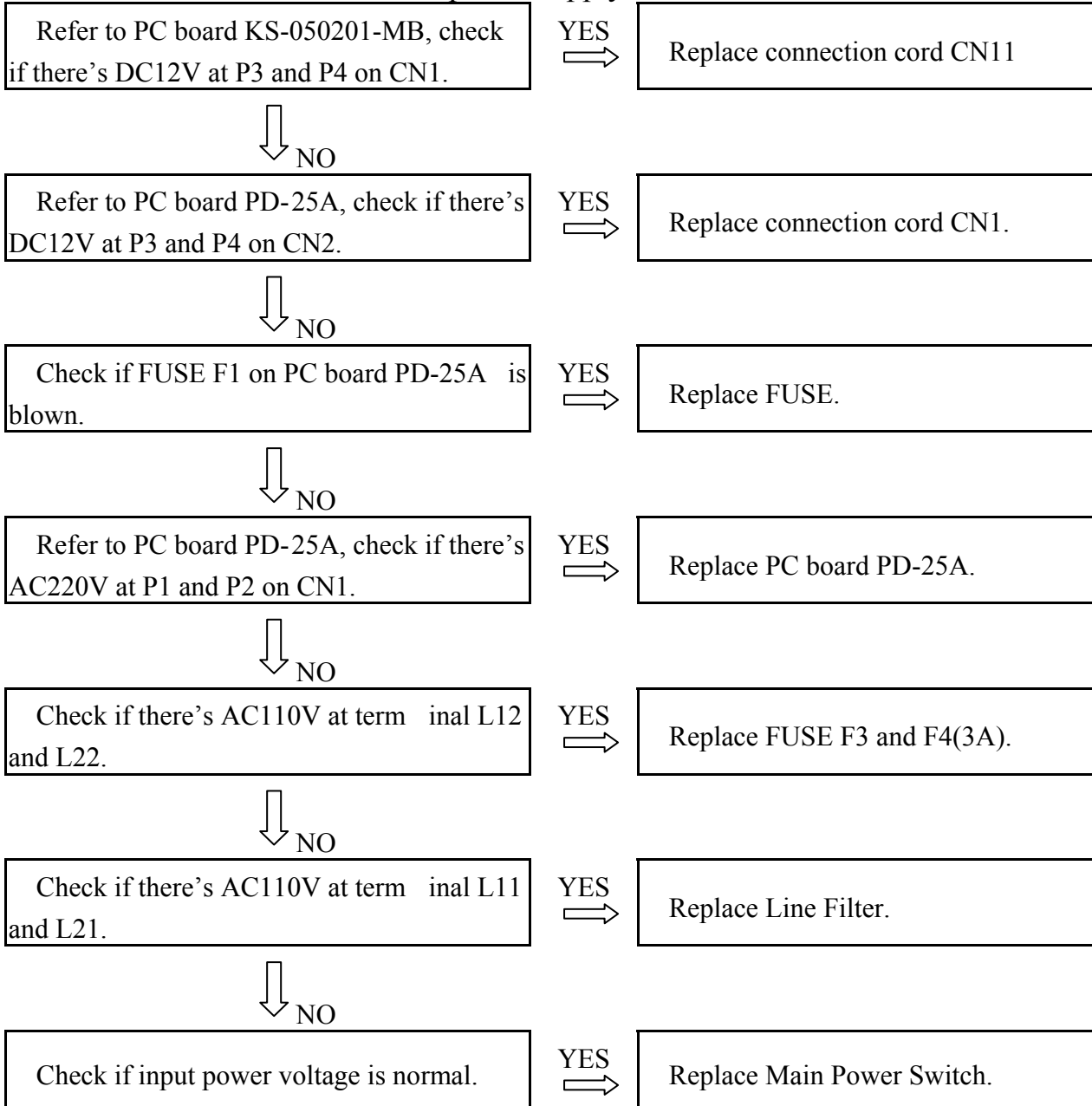

11-1-3 There isn't DC24 Volt. on power supply PS-65-24

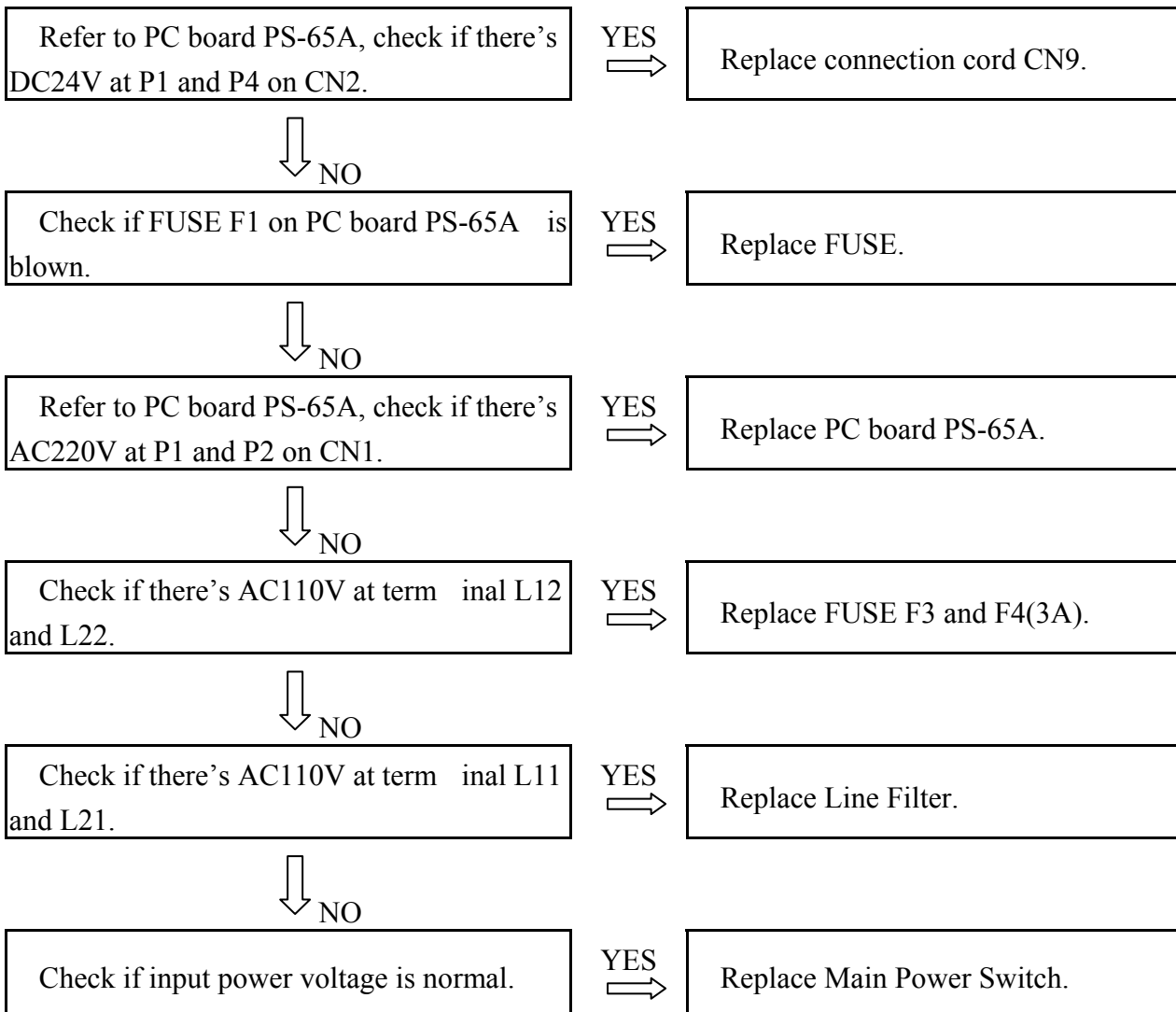

### 11-2-1 Turntable motor not operating (Inverter)

Condition:

- a.) LED M1 is lighting up on PC board KS-050202-KEY.
- b.) Emergency Stop is normal and does not be activated.
- c.) Variable resister VR1 has been normal and has been turned to maximum position.
- d.) There's AC110V at terminal R and T on Inverter IVR1.
- e.) Touch Start key and start LED light up.

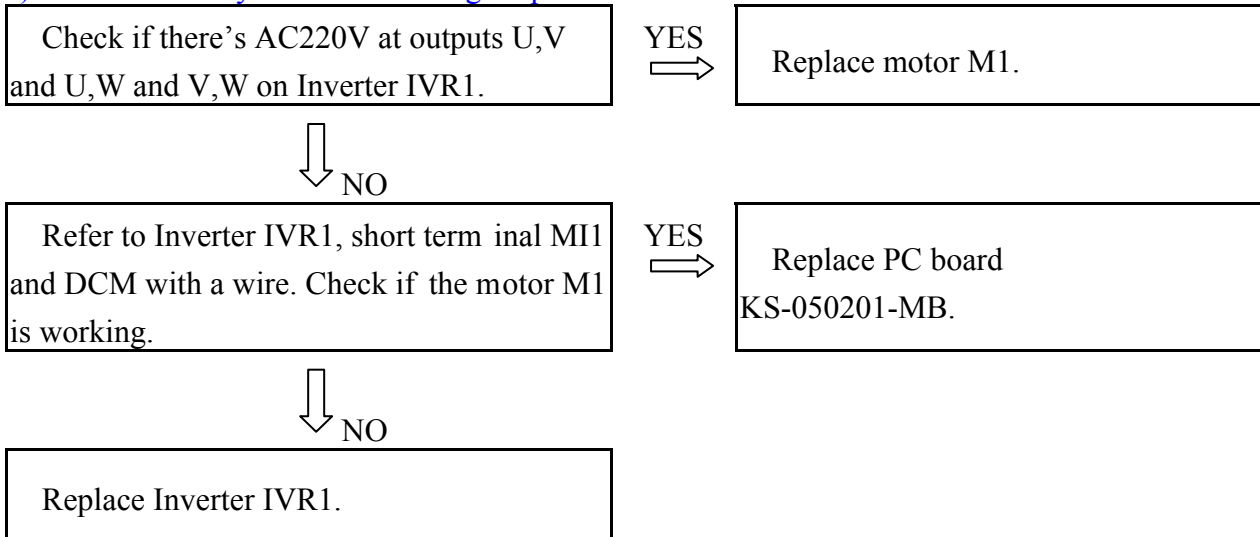

### 11-2-2. Turntable motor speed not adjustable

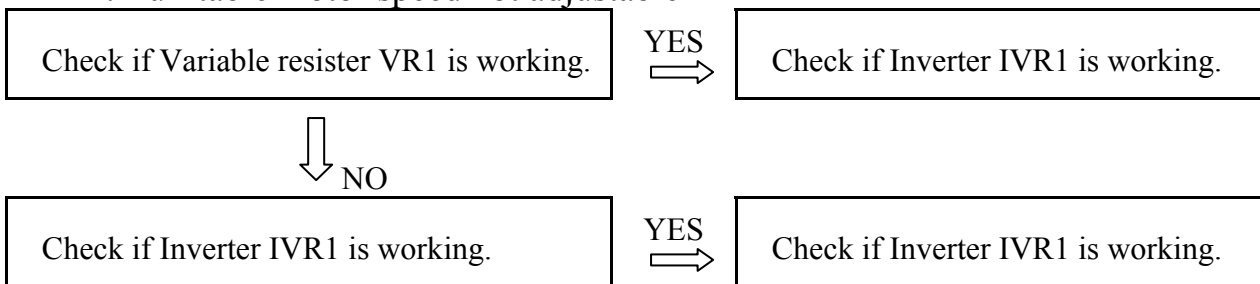

### 11-3-1 Film-seat motor brake (BK2) not working

Condition:

- a). Relay RYBK2 is working on PC board KS-050201-MB and LED BK2 would light up.
- b). Fuse F1 (2A) on PC board KS-050201-MB is normal. (If a fuse F1 was blown, red LED BK2 Fuse fail on PC board KS-050202-KEY would light up.)

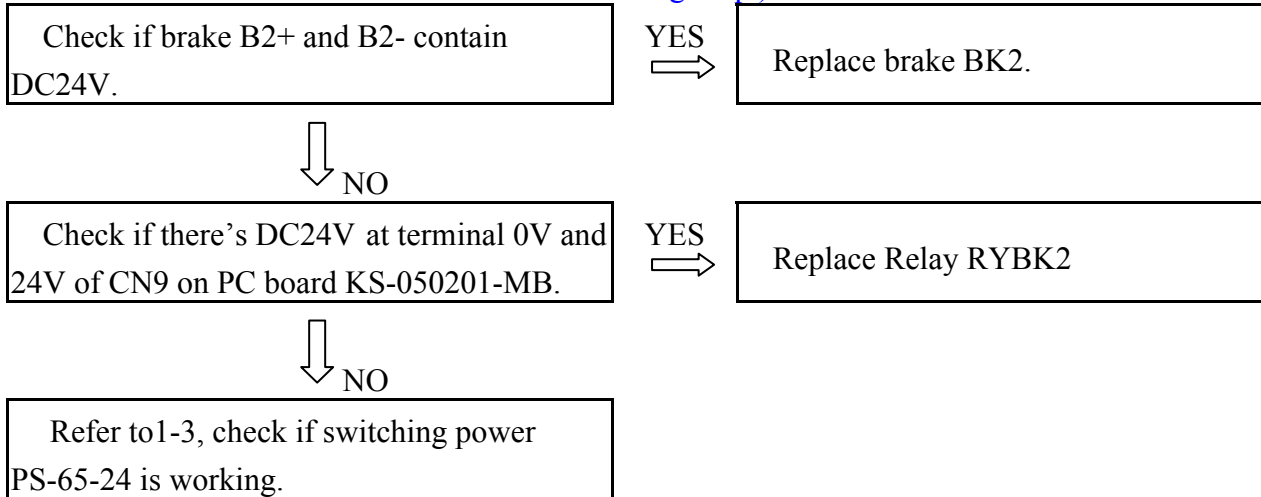

## 11-3-2 Film-seat elevator motor not rising

Condition:

- LED M2 is lighting up on PC board KS-050202-KEY. IC OP1 has controlled elevator rising.
- Relay RYBK2 is working, LED BK2 on PC board KS-050202-KEY and LD26 on PC board KS-050201-MB are lighting up. Relay RYBK2 has controlled brake BK2 working.
- Brake BK2 is working.
- LED MD and MD1 can't work at the same time when LED MU and MU1 are working.
- There's AC110V at terminal R and S terminal on Inverter IVR2.
- Emergency Stop is normal and does not activate.
- Variable resistor VR2 has been normal and has been turned to maximum position.

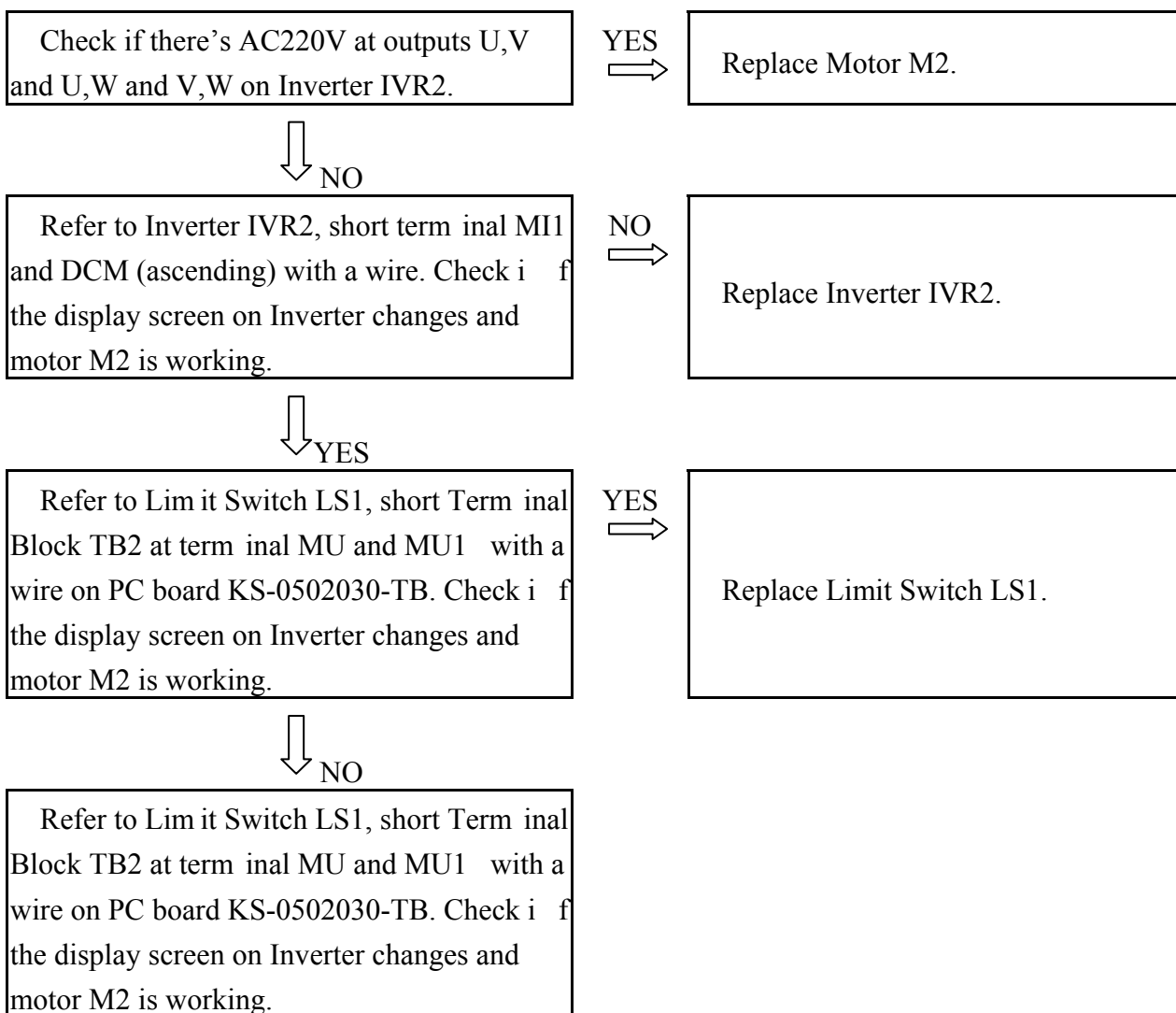

### 11-3-3 Film-seat elevator motor not setting

Condition:

- a). LED M2 is lighting up on PC board KS-050202-KEY. IC OP2 has controlled elevator setting.
- b). Relay RYBK2 is working, LED BK2 on PC board KS-050202-KEY and LD26 on PC board KS-050201-MB are lighting up. Relay RYBK2 has controlled brake BK2 working.
- c). Brake BK2 is working.
- d). LED MU and MU1 can't work at the same time when LED MD and MD1 are working.
- e). There's AC110V at terminal R and S terminal on Inverter IVR2.
- f). Emergency Stop is normal and does not activate.
- g). Variable resistor VR2 has been normal and has been turned to maximum position.
- h). Limit Switch LS2,LS2-1,LS2-2 doesn't be activated.

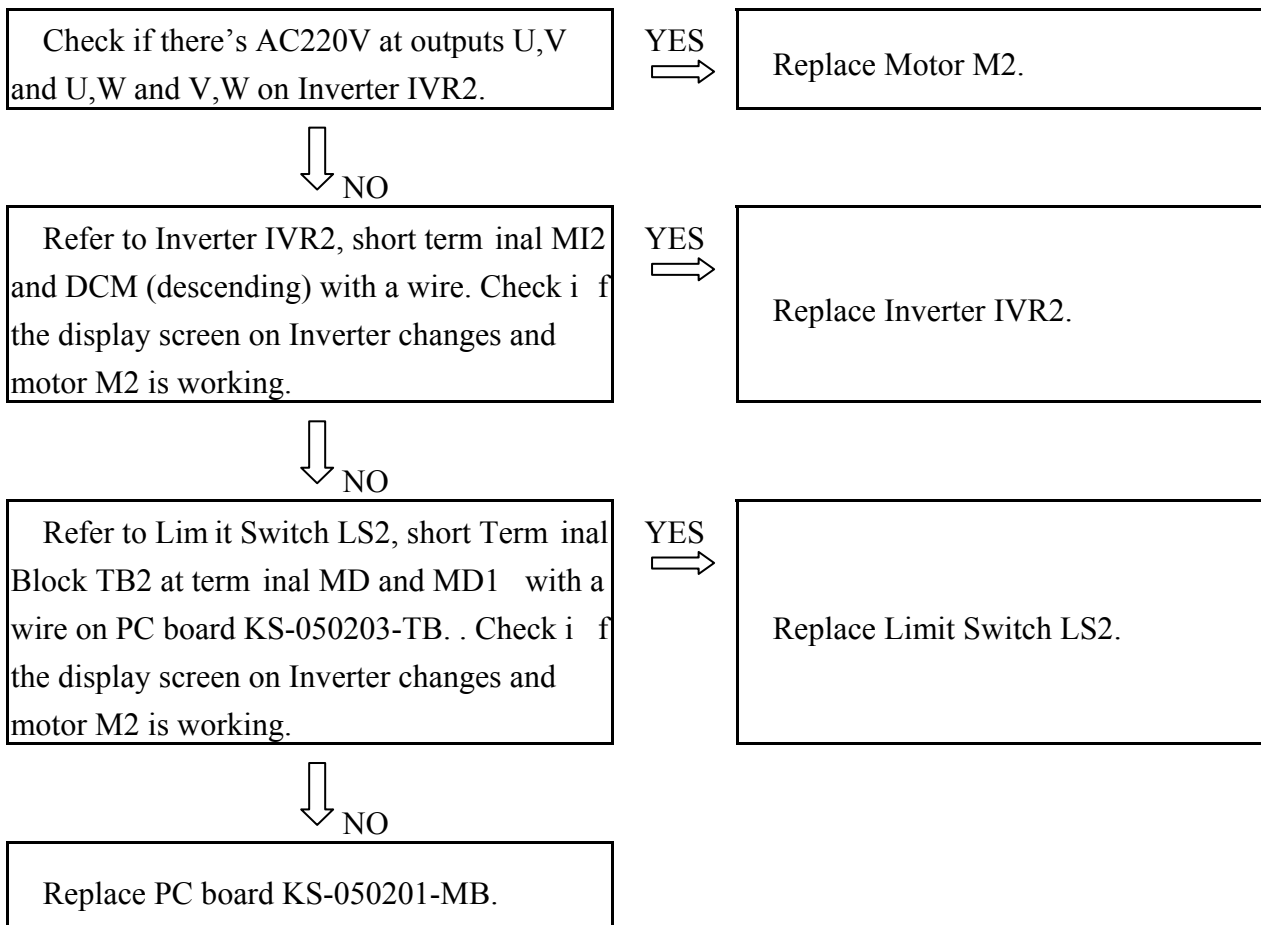

### 11-4 Film-seat doesn't stop when reached package limit

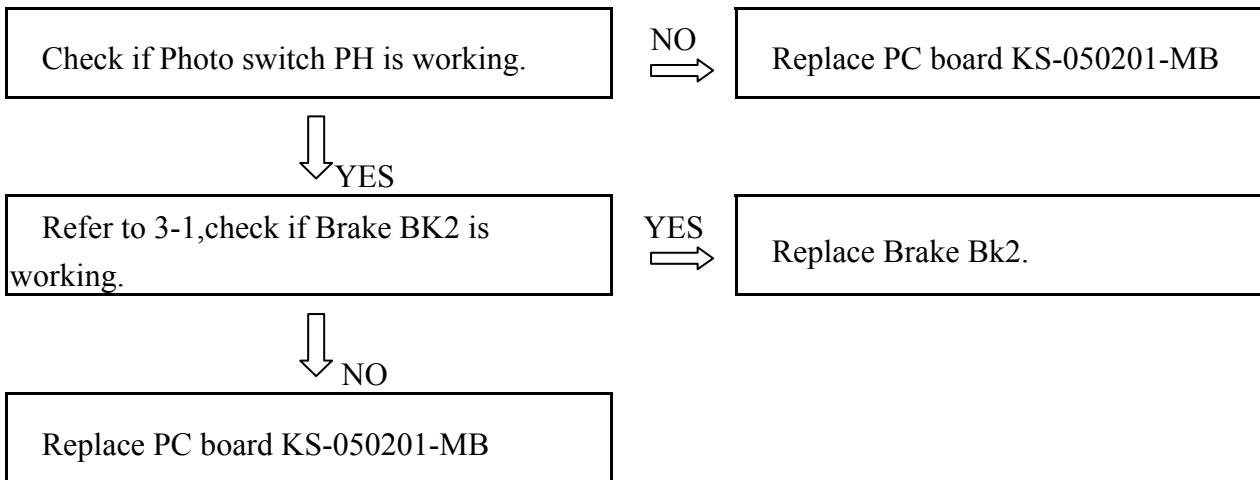

### 11-5 Film-seat doesn't pause

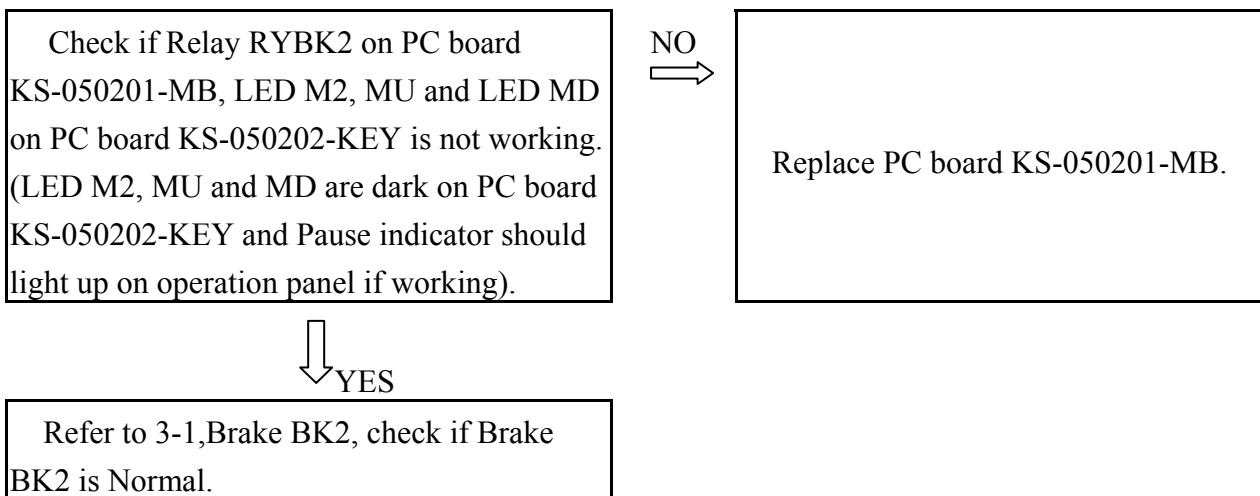



## 11-6-1 Film-seat doesn't stop after reaching maximum packaging limit

Condition:

- a). LED LS1 lights up on PC board KS-050202-KEY when Film-seat touched limit switch LS1.
- b). Brake BK2 is normal.
- c). LED M2, MU and MD are dark on PC board KS-050202-KEY.

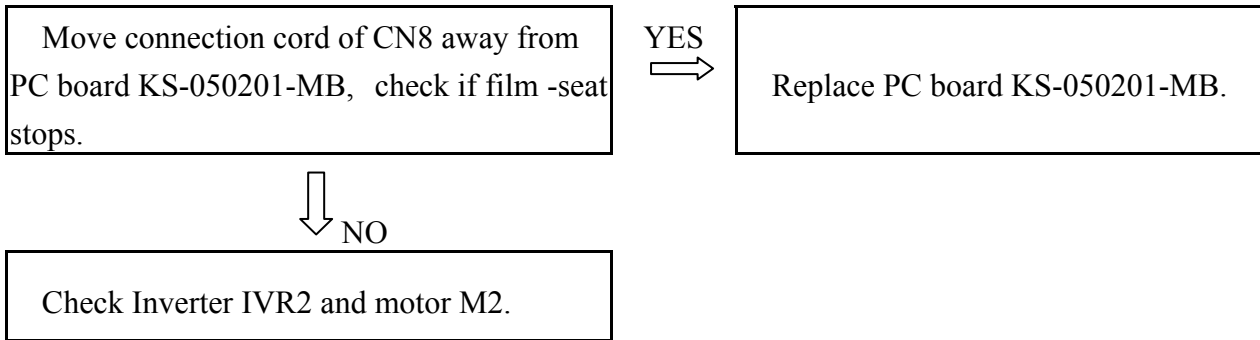

### 11-6-2 Film-seat doesn't stop after returning to starting position

Condition:

- a). LED LS2 lights up on PC board KS-050202-KEY when Film-seat touched limit switch LS2.
- b). Brake BK2 is normal.
- c). LED M2, MU and MD are dark on PC board KS-050202-KEY.

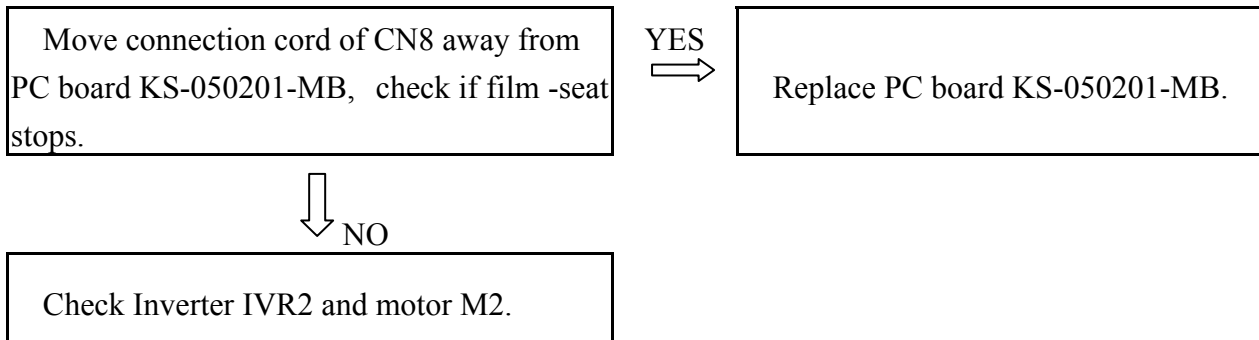

### 11-6-3 Film-seat motor speed not adjustable

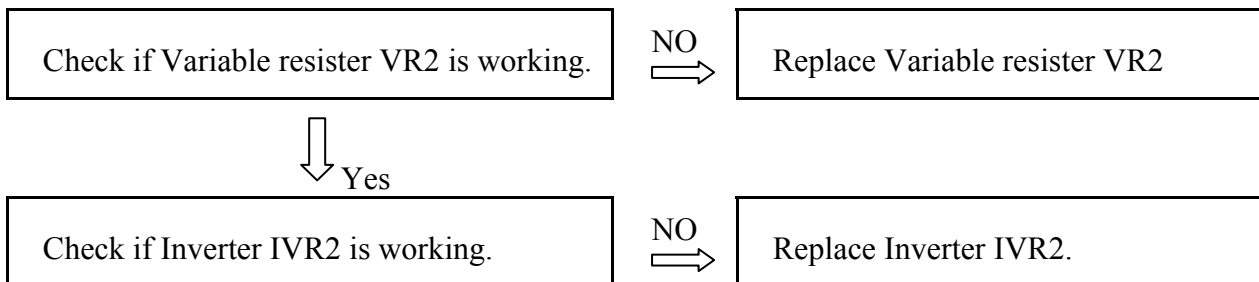

### 11-7-1 Turntable hasn't slowed down before completing wrapping cycle

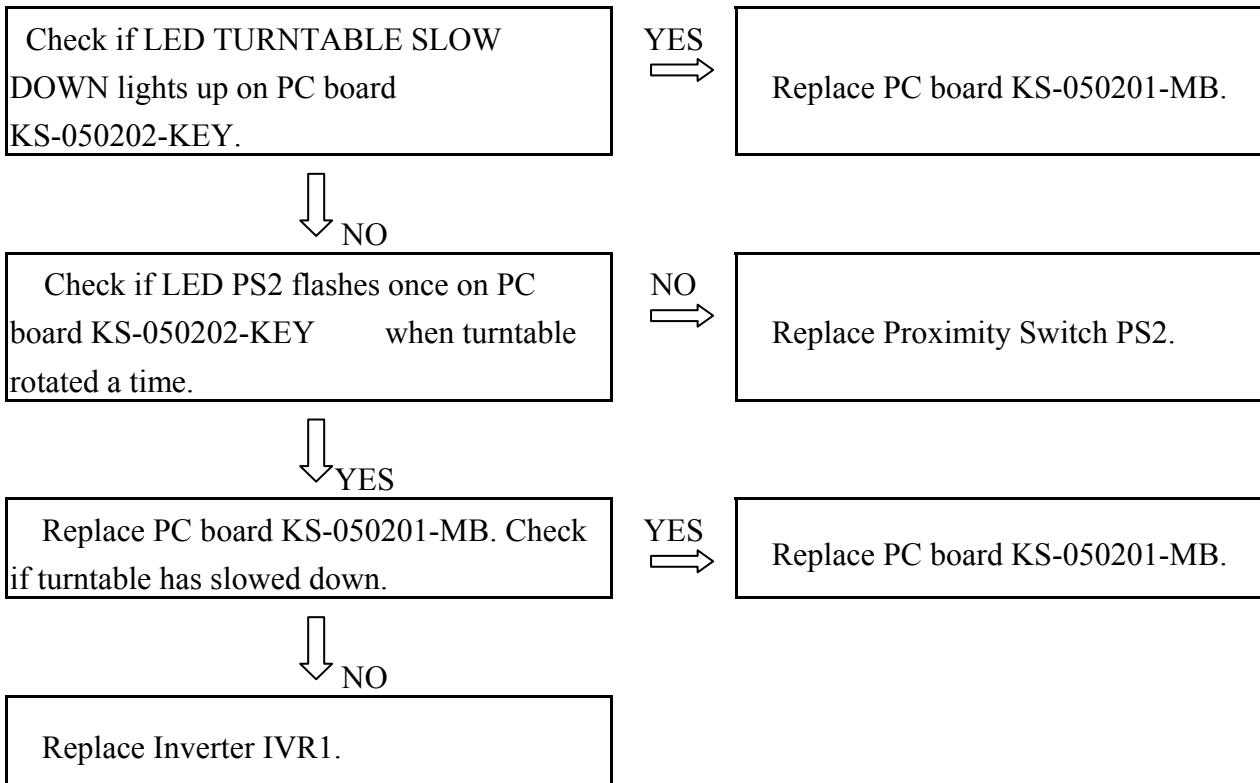

## 11-7-2 Turntable doesn't stop after completing wrapping cycle

Condition:

a). Turntable has slowed down.

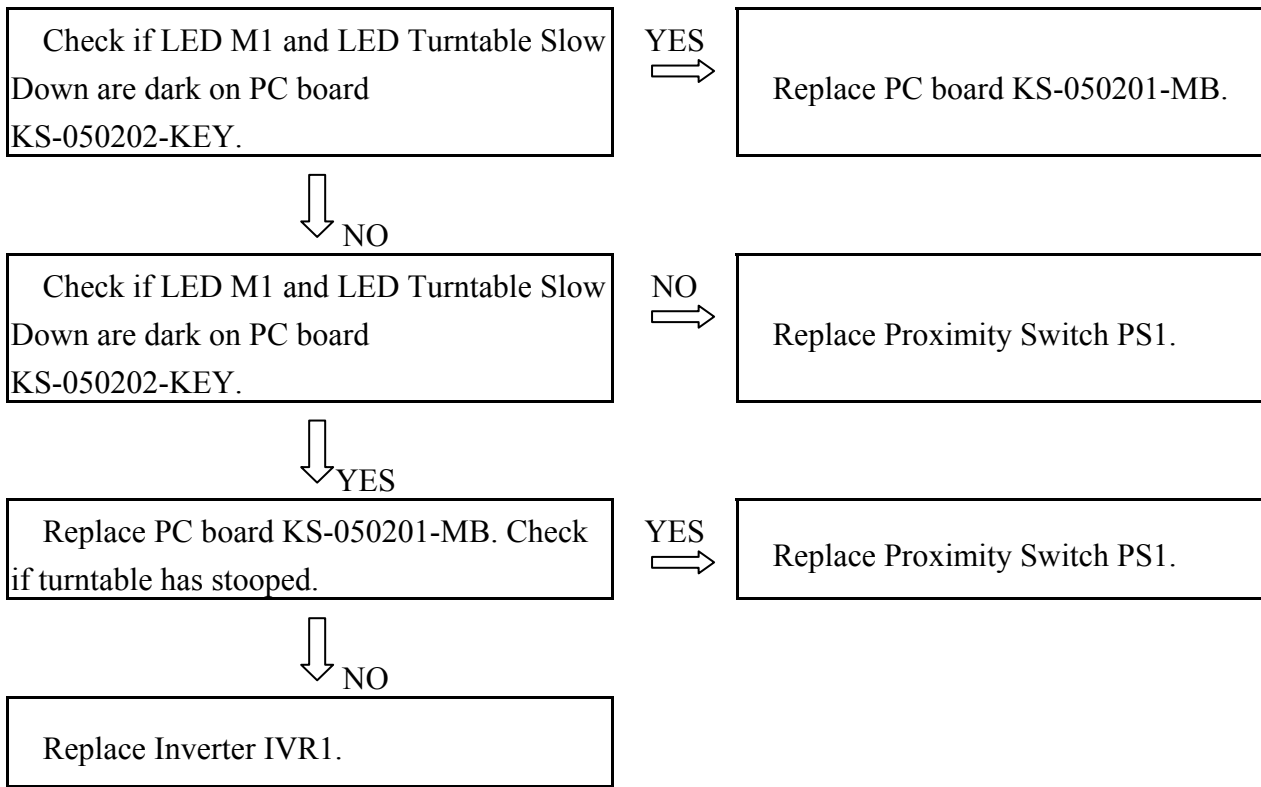

11-8 LS1, LS2, LS2-1, LS2-2, PS1, PS2 and PH not operating normally on PC board KS-050202-KEY

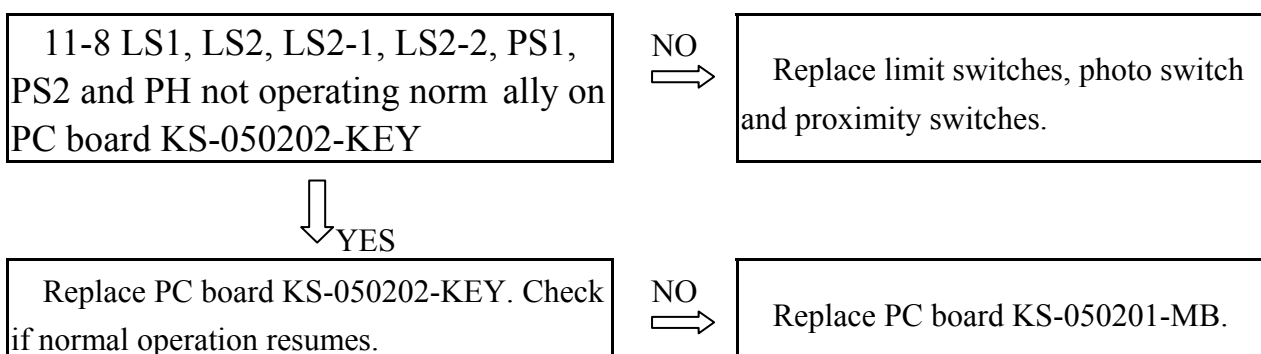

## 11-9. Control panel buttons not working

Condition:

- a). Power supply SP1 is normal (DC5V and DC12V).
- b). Emergency Stop is normal and does not be activated.
- c). Fuse F3 and F4 are normal.

Replace connection cord CN2 26P and CN4 50P on PC board KS-050202-KEY and then check if normal operation resumes.

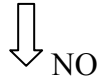

Replace PC board KS-050202-KEY and then check if normal operation resumes.

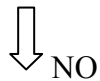

Replace PC board KS-050202-KEY and then check if normal operation resumes.

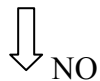

Contact manufacturer.

11-10 Pre-stetch motor M3 hasn't worked:

Condition:

- a). LED M3 lights up on PC board KS-050202-KEY.
- b). There's AC110V at terminal R and S terminal on Inverter IVR3.
- c). Power supply SP2 has worked normal. (Supply DC24V to proximity switch SPS1)

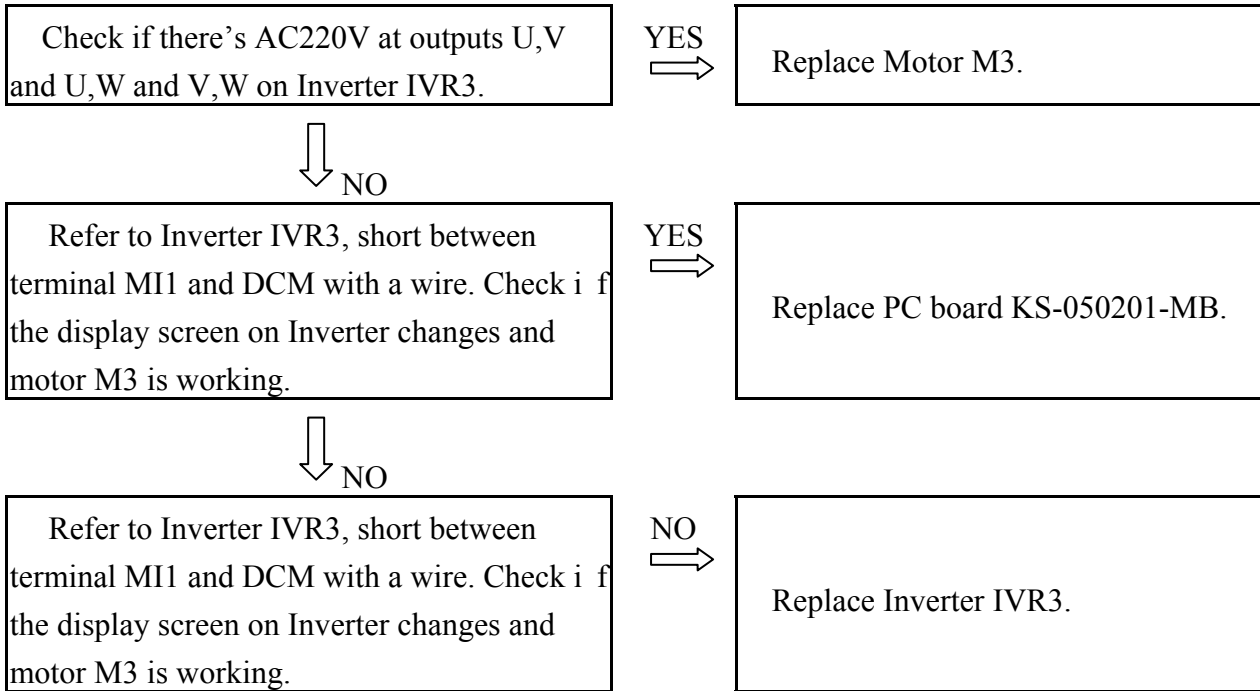

## 12 Machine parts diagram

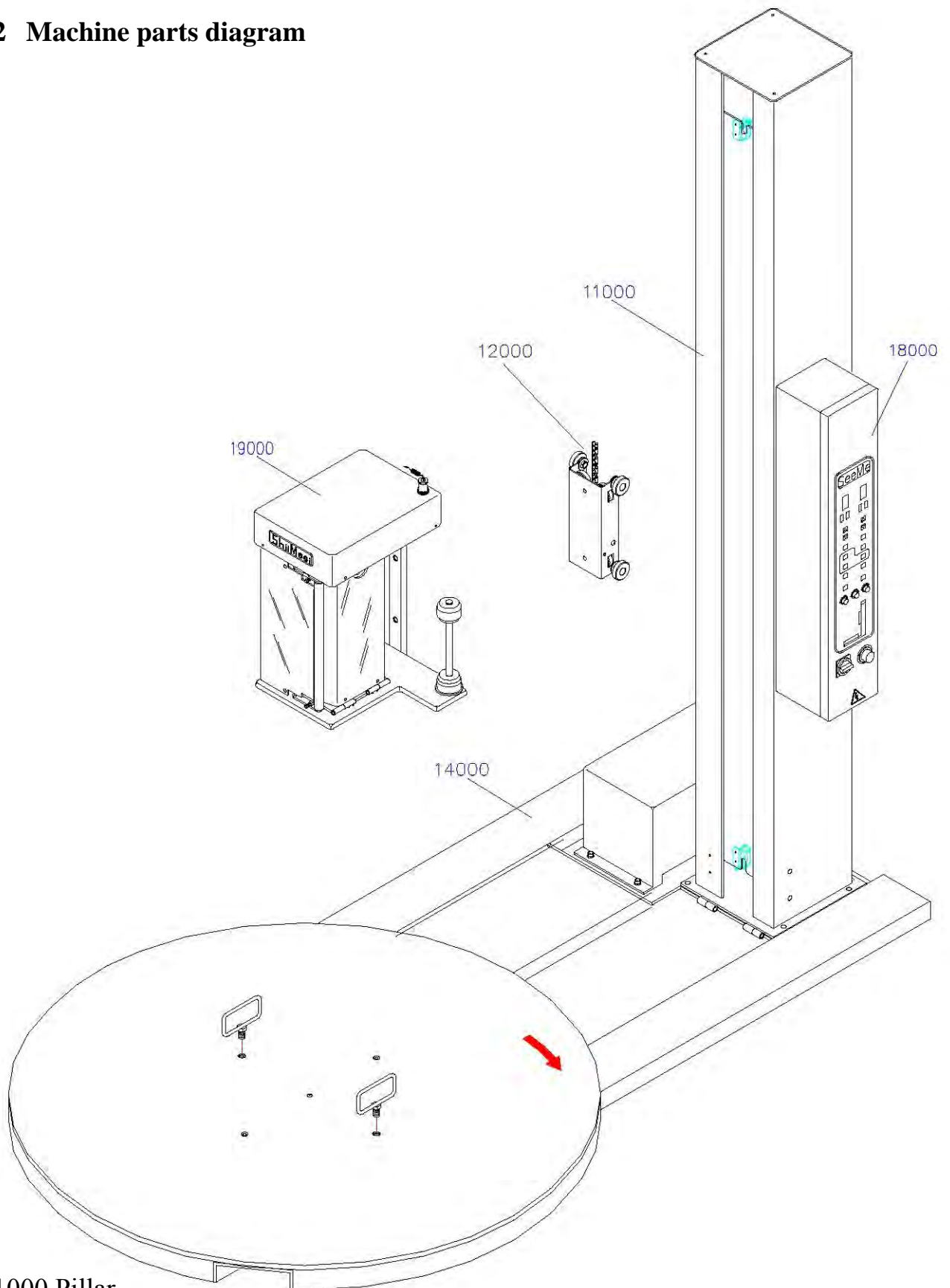

11000 Pillar

12000 Film -Seat

14000 Bottom Plate

18000 Control Box

19000 Pre-stretch Unit

12-1-1 Fig-11000 Pillar Parts Diagram

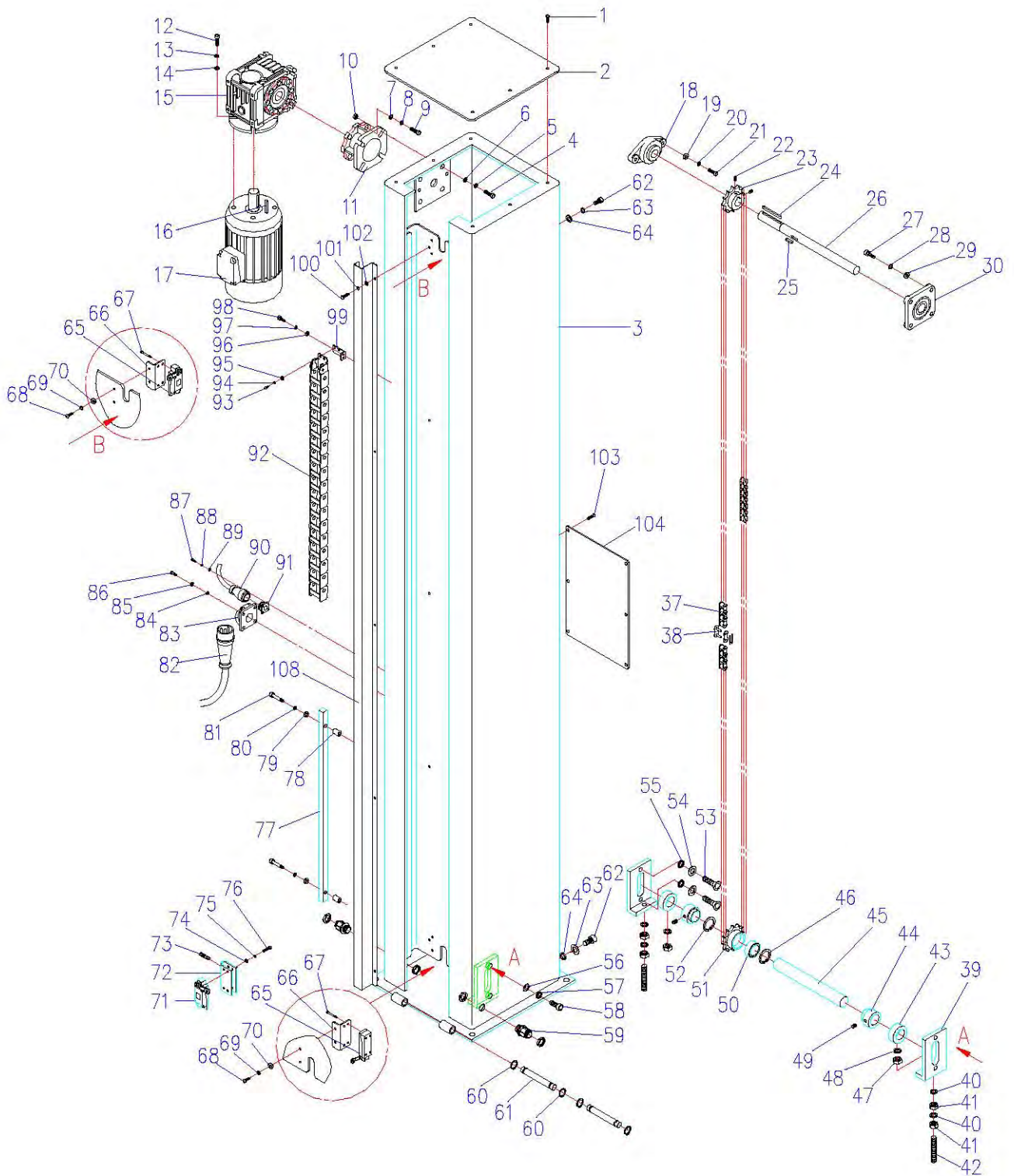



12-1-2. Fig-1100 Pillar parts table (1)

Ref.	Part No.	Description	Qty	Remarks
1	FMS-6 x 15	M6 x 15 Flat Machine Screw	6	
2	1506-11002	Bracket	1	
3	1506-11003	Pillar	1	
4	CAP-8 x 30	M8×30 Hexagon Square Head Bolt	4	
5	SPW-8	M8 Spring Washer	4	
6	WS-8	M8 Plan Washer	4	
7	BH-8 x 30	M8×30 Hex Socket Head Bolt	4	
8	SPW-8	M8 Spring Washer	4	
9	WS-8	M8 Plan Washer	4	
10	HN-8	M8 Hexagon Nut	4	
11	1506-11011	Flange	1	
12	BH-8 x 30	M8×30 Hex Socket Head Bolt	4	
13	SPW-8	M8 Spring Washer	4	
14	WS-8	M8 Plan Washer	4	
15	1517R-11015	Reduction Worm Gear 1:100	1	
16	Key-6×6×30	6 x 6 x 30 Key	1	
17	1506-11017	Motor 220V 1/2HP 3ph	1	
18	UCFL-204	UCFL-204 Bearing	1	
19	WS-12	M12 Plan Washer	2	
20	SPW-12	M12 Spring Washer	2	
21	CAP-12×30	M12×30 Hexagon Square Head Bolt	2	
22	1506-11022	M8 x 8 Hex Socket Head Set Screw	2	
23	1506-11023	#40 x 17T x $\phi$ 20 x 6 Sprocket	1	
24	Key-6×6×65	6 x 6 x 65 Key	1	
25	Key-6×6×30	6 x 6 x 30 Key	1	
26	1517R-11026	Shaft $\phi$ 20 x 370L	1	
27	CAP-12x 30	M12×30 Hexagon Square Head Bolt	4	
28	SPW-12	M12 Spring Washer	4	
29	WS-12	M12 Plan Washer	4	
30	UCF-204	UCF-204 Bearing	1	
31	1506-11031	None	0	
32	1506-11032	None	0	
33	1506-11033	None	0	
34	1506-11034	None	0	
35	1506-11035	None	0	
36	1506-11036	None	0	
37	1506-11037	#40 x 350L Chain (Standard Size)	1	

12-1-2. Fig-1100 Pillar parts table (2)

Ref.	Part No.	Description	Qty	Remarks
38	1506-11038	#40 Chain Link	1	
39	1506-11039	Bracket	2	
40	SPW-8	M8 Spring Washer	4	
41	HN-8	M8 Hexagon Nut	4	
42	1517-11042	M8 x 75L Screw	2	
43	1517-11043	Ring 38 x 15 x 20 (D x W x d)	2	
44	1517-11044	Ring 32 x 15 x 20 (D x W x d)	2	
45	1517-11045	Shaft $\psi$ 20-265	1	
46	RTW-37	"R" Snap Ring $\psi$ 37	1	
47	HN-8	M8 Hexagon Nut	2	
48	SPW-8	M8 Spring Washer	2	
49	HSS-6 x 6	M6 x 6 Hex Socket Head Set Screw	2	
50	6904ZZ	6904ZZ Bearing	1	
51	6904ZZ	#40 x 17T x $\phi$ 37 Sprocket	1	
52	1506-11052	None	1	
53	CAP-8 x 16	M8 x 16 Hexagon Square Head Bolt	2	
54	SPW-8	M8 Spring Washer	2	
55	WS-8	M8 Plan Washer	2	
56	WS-8	M8 Plan Washer	2	
57	SPW-8	M8 Spring Washer	2	
58	CAP-8 x 16	M8 x 16 Hexagon Square Head Bolt	2	
59	ATM-2	ATM-2 TIE MOUNTS	1	
60	STW-14	"S" Snap Ring $\phi$ 14	4	
61	1506-11061	Shaft-14- 90L	2	
62	1506-11062	None	0	
63	1506-11063	None	0	
64	1506-11064	None	0	
65	TZ-8108	Limit Switch TZ8104, 5A 250V AC	2	
66	1506-11066	Switch Bracket	2	
67	BH-5x12	M5 $\times$ 12 Hex Socket Head Bolt	4	
68	BH-5 $\times$ 10	M5 $\times$ 10 Cross Recessed Round Head Screw	4	
69	SPW-5	M5 Spring Washer	4	
70	WS-5	M5 Plan Washer	4	
71	TZ-8104	Limit Switch TZ8104, 5A 250V AC	1	
72	1506-11072	Switch Plate	1	
73	HSS-6 x 16	M6 x 16 Hex Socket Head Set Screw	1	
74	WS-5	M5 Plan Washer	2	

12-1-2. Fig-1100 Pillar parts table (3)

Ref.	Part No.	Description	Qty	Remarks
75	SPW-5	M5 Spring Washer	2	
76	BH-5 x 35	M5 x 35 Hex Socket Head Bolt	2	
77	1506-11077	Guide 13 x 13 x 300L	1	
78	1506-11078	Ring 12 x 13 x 6 (D x W x d)	2	
79	WS-6	M6 Plan Washer	2	
80	SPW-6	M6 Spring Washer	2	
81	BH-6 x 35	M6 x 35 Hex Socket Head Bolt	2	
82	1506-11082	CP11401627 IP67	1	
83	1506-11083	CP00401627 IP67	1	
84	WS-4	M4 Plan Washer	4	
85	SPW-4	M4 Spring Washer	4	
86	PMS-4x10	M4×10 Round Head Screw	4	
87	PMS-3×10	M3 x 10 Round Head Screw	4	
88	SPW-3	M3 Spring Washer	4	
89	WS-3	M3 Plan Washer	4	
90	1506-11090	Plug XP2	1	
91	1506-11091	Socket XS2	1	
92	1506-11092	Cable Chain	1	
93	1517R-19093	M5 x 10 Flat Machine Screw	2	
94	SPW-5	M5 Spring Washer	2	
95	WS- 5	M5 Plan Washer	2	
96	WS-5	WS-5	2	
97	SPW-5	M5 Spring Washer	2	
98	CAP-5x 10	M5 x 10 Hexagon Square Head Bolt	2	
99	1506-11099	Cable Chain Plate	1	
100	BH-5×10	M5×10 Cross Recessed Round Head Screw	5	
101	SPW-5	M5 Spring Washer	5	
102	WS-5	M5 Plan Washer	5	
103	FMS-5x10	Flat Machine Screw M5x10	6	
104	1506-11104	Assembly Cover	1	

12-2-1. Fig-12000 Film-seat Elevator parts diagram

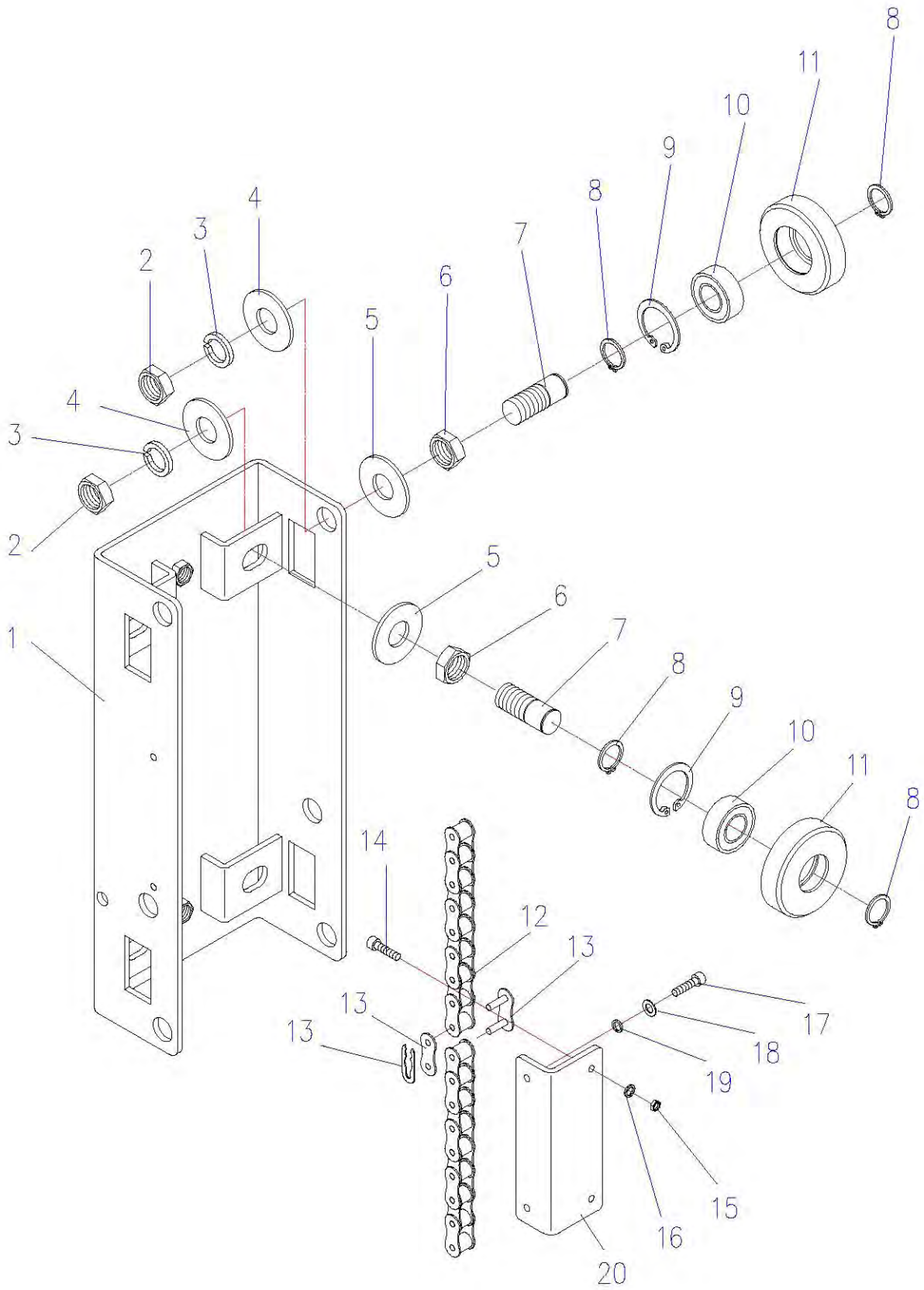

12-2-2. Fig-12000 Film-seat Elevator parts table

Ref.	Part No.	Description	Qty	Remarks
1	1506-12001	Film-set Elevator Base	1	
2	HN-15	M15 Hexagon Nut	8	
3	SPW-15	M15 Hexagon Nut	8	
4	WS -15	M15 Plan Washer	8	
5	WS-15	M15 Plan Washer	8	
6	HN-15	M15 Hexagon Nut	8	
7	1506-12007	Shaft	8	
8	STW-15	"S" Snap Ring $\phi$ 15	16	
9	RTW-32	"R" Snap Ring $\phi$ 32	8	
10	6002ZZ	6002ZZ Bearing	8	
11	1506-12011	Roller	8	
12	1506-12012	#40 Chain	1	
13	1506-12013	#40 Chain Link	1	
14	CAP-6×25	M5×25 Hexagon Square Head Bolt	2	
15	1506-12015	M5 Hexagon Nut	2	
16	SPW- 6	M5 Hexagon Nut	2	
17	CAP-6×15	M6×15 Hexagon Square Head Bolt	2	
18	SPW-6	M6 Spring Washer	2	
19	WS-6	M6 Plan Washer	2	
20	1506-12020	Chain Cover	1	

12-3-1 Fig-14000 Bottom Plate Diagram

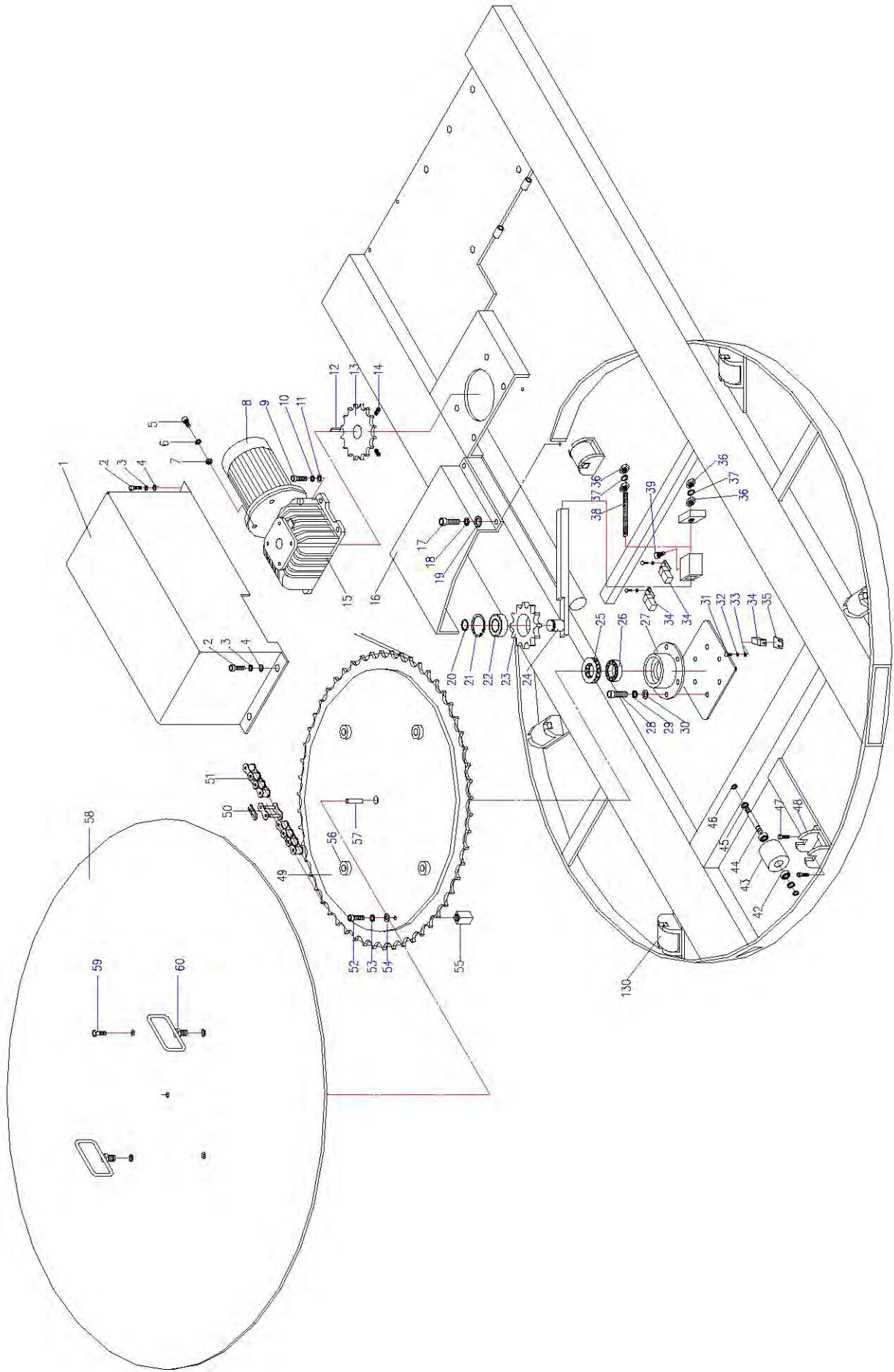

12-3-2 Fig-14000 Bottom Plate parts Table (1)

Ref.	Part No.	Description	Qty.	Remarks
1	1517-14001	Motor Cover	1	
2	CAP-6×15	M6 x 15 Hexagon Square Head Bolt	4	
3	SPW-6	M6 Spring Washer	4	
4	WS-6	M6 Plan Washer	4	
5	CAP-10×25	M10×25 Hexagon Square Head Bolt	4	
6	SPW-10	M10 Spring Washer	4	
7	WS-10	M10 Plan Washer	4	
8	1517-14008	Motor 1HP 50/60Hz , 220/380V	1	
9	CAP-10×25	M10×25 Hexagon Square Head Bolt	4	
10	SPW-10	M10 Spring Washer	4	
11	WS-10	M10 Plan Washer	4	
12	KEY-7-40	7×7×40 Key	1	
13	S50-19T-28-7	#50×19T-28-7 Sprocket	1	
14	HSS-8×8	M8×8 Hex Socket Head Set Screw	2	
15	UMW-70	#70 Reduction Worm Gear 1:30	1	
16	1517-14016	Chain Cover	1	
17	CAP-6x10	M6×10 Hexagon Square Head Bolt	2	
18	SPW-6	M6 Spring Washer	2	
19	WS-6	M6 Plan Washer	2	
20	STW-17	"S" Snap Ring $\phi$ 17	1	
21	RTW-30	"R" Snap Ring $\phi$ 30	1	
22	6903ZZ	6903ZZ Bearing	1	
23	S50-12T	#50×12T Sprocket	1	
24	1517-14024	Pressing Arm	1	
25	1517-14025	51211 Bearing	1	
26	1517-14026	6005ZZ Bearing	1	
27	1517-14027	Bearing Set	1	
28	CAP-8x	M8×25 Hexagon Square Head Bolt	6	
29	SPW-8	M8 Spring Washer	6	
30	WS-8	M8 Plan Washer	6	
31	PMS-4×8	M3 x20 Round Head Screw	6	
32	SPW-3	M3 Spring Washer	6	
33	WS-3	M3 Plan Washer	6	
34	1517-14034	TP-SM5N1 Proximity Switch	4	
35	1517-14035	Proximity Switch Set	4	
36	HN-8	M8 Hexagon Nut	4	
37	SPW-8	M8 Spring Washer	2	

12-3-2 Fig-14000 Bottom Plate parts Table (2)

Ref.	Part No.	Description	Qty.	Remarks
38	1517-14038	M8×100L Screw	1	
39	CAP-8×15	M8×15 Hexagon Square Head Bolt	2	
40	None	None	0	
41	None	None	0	
42	6002ZZ	6002ZZ Bearing	2	
43	1517-14043	Roller	1	
44	SH-15-110	φ 15×110 Shaft	1	
45	1517-14045	φ 23×1.2× φ 15 Washer (D × W × d)	2	
46	STW-15	"S" Snap Ring φ 15	2	
47	CAP-6×25	M6×25 Hexagon Square Head Bolt	12	
48	1517-14048	Roller Seat	6	
49	S50-85T	#50×85T Sprocket	1	
50	1517-14050	#50 Chain Link	1	
51	1517-14051	#50×216L Chain	1	
52	CAP-6×20	M6×20 Hexagon Square Head Bolt	1	
53	SPW-6	M6 Spring Washer	1	
54	WS-6	M6 Plan Washer	1	
55	1517-14055	Proximity Switch Sense Bar	1	
56	R-25-16-17	Ring φ 25x16x φ 17 (D x L x d)	4	
57	PIN-8-50	8×50 Pin	1	
58	1517-14058	φ 1500 Turntable	1	
59	FMS-12×40	M12x40 Flat Machine Screw	4	
60	1517-14062	Ring Bolt	2	
130	1517-14130	Roller Unit	6	



# 12-4-1 Fig-18000 Control Box Diagram

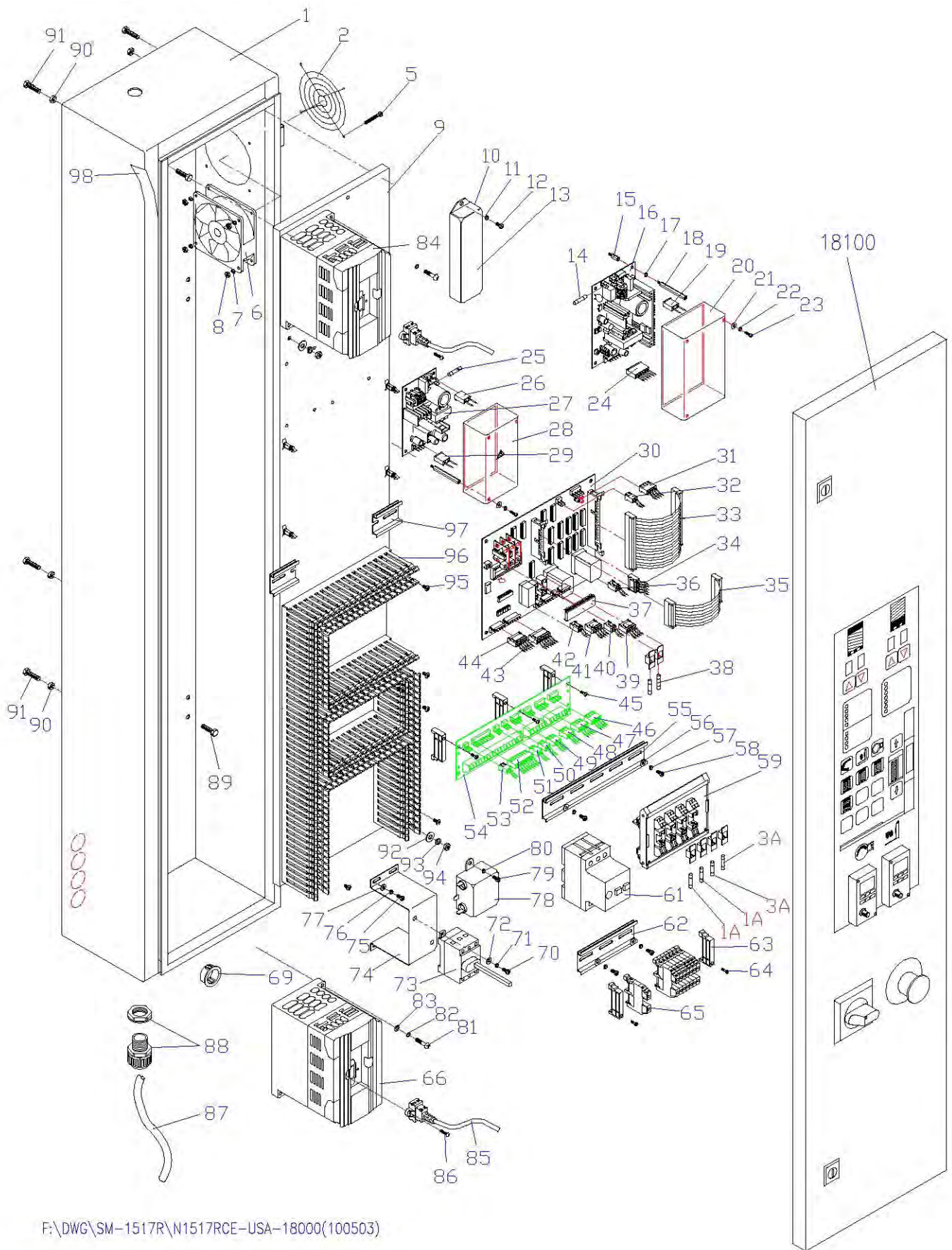

F:\DWG\SM-1517R\N1517RCE-USA-18000(100503)

12-4-2 Fig-18000 Control Box Table (1)

Ref.	Part No.	Description	Qty.	Remarks
1	1517R-18001	Control Box	1	
2	1517R-18002	Fun Safety Web	2	
3	None	None	0	
4	None	None	0	
5	PMS-4×35	M4×35 Round Head Screw	4	
6	1517R-18006	Fun SJ-8025HA2SAL	1	
7	WS-4	M4 Plan Washer	4	
8	HN-4	M4 Hexagon Nut	4	
9	1517R-18009	Bracket for Control Box	1	
10	1517R-18010	Resister 80W 200Ω	1	
11	SPW-4	M4 Spring Washer	2	
12	PMS-4×15	M4 x15 Round Head Screw	2	
13	None	None	0	
14	1517R-18014	Fuse GFE 4A	1	
15	1517R-18015	Copper Support 17mm	4	
16	1517R-18016	Power Supplies PS-65-24	1	
17	SPW-4	M4 Spring Washer	4	
18	1517R-18018	Copper Support 42mm	4	
19	1517R-18019	Electric Cable 3.96-3P	1	
20	1517R-18020	Protection Cover	1	
21	SPW-3	M3 Spring Washer	4	
22	WS-3	M3 Plan Washer	4	
23	PMS-3×15	M3 x15 Round Head Screw	4	
24	1517R-18024	Electric Cable 3.96-6P	1	
25	1517R-18025	Fuse S2.5A	1	
26	1517R-18026	Electric Cable 3.96-3P	1	
27	1517R-18027	Power Supplies PD-25A	1	
28	1517R-18028	Protection Cover	1	
29	1517R-18029	Electric Cable 3.96-4P	1	
30	1517R-18030	PCB KS-050201-MB	1	
31	1517R-18031	Electric Cable VH-4P	1	
32	1517R-18032	Electric Cable VH-2P	1	
33	1517R-18033	WIRE Cable 50P	1	
34	1517R-18034	Electric Cable VH-5P	1	
35	1517R-18035	WIRE Cable 26P	1	
36	1517R-18036	Electric Cable VH-2P	1	

12-4-2 Fig-18000 Control Box Table (2)

Ref.	Part No.	Description	Qty.	Remarks
37	1517R-18037	IC Please specify main PC board's IC version when place order	1	
38	1517R-18038	Fuse GFE 2A/GFE1A	2	
39	1517R-18039	Electric Cable VH-4P	1	
40	1517R-18040	Electric Cable VH-2P	1	
41	1517R-18041	Electric Cable VH-4P	1	
42	1517R-18042	Electric Cable VH-2P	1	
43	1517R-18043	Electric Cable VH-6P	1	
44	1517R-18044	Electric Cable VH-5P	1	
45	1517R-18045	3/16 x15 Round Head Screw	3	
46	1517R-18046	Electric Cable VH-4P	1	
47	1517R-18047	Electric Cable VH-4P	1	
48	1517R-18048	Electric Cable VH-3P	1	
49	1517R-18049	Electric Cable VH-3P	1	
50	1517R-18050	Electric Cable VH-2P	1	
51	1517R-18051	Electric Cable VH-2P	1	
52	1517R-18052	Electric Cable VH-8P	1	
53	1517R-18053	Electric Cable VH-2P	1	
54	1517R-18054	Terminal Block PCB KS-050203-TB	1	
55	1517R-18055	RAIL L TS35	1	
56	PMS-4x6	M4x6 Round Head Screw	2	
57	WS-4	M4 Plan Washer	2	
58	SPW-4	M4 Spring Washer	2	
59	1517R-18059	Fuse Base FM-04-L-OP-B	1	
60	1517R-18060	Fuse GFE 1A,1A,2A,2A	4	
61	1517R-18061	MOTOR BREAKER MS25-10	1	
62	1517R-18062	RAIL L TS35	1	
63	1517R-18063	END STOPPER TBRF	2	
64	1517R-18064	M4x6 Cross Recessed Round Head Screw	4	
65	1517R-18065	Terminal Block D4/6	16	
66	1517R-18066	Inverter <b>VFD004E11T</b>	1	
67	None	None	0	
68	None	None	0	
69	1517R-18069	φ 24 Hole Plugs	4	
70	1517R-18070	M4x10 Round Head Screw	2	
71	SPW-4	M4 Spring Washer	2	
72	WS-4	M4 Plan Washer	2	

12-4-2 Fig-18000 Control Box Table (3)

Ref.	Part No.	Description	Qty.	Remarks
73	1517R-18073	Disconnect Switch ABB OT16F3	1	
74	1517R-18074	Disconnect Switch Base	1	
75	PMS-4x10	M4x10 Round Head Screw	4	
76	SPW-4	M4 Spring Washer	4	
77	WS-4	M4 Plan Washer	4	
78	1517R-18078	Line Filter 10SS4-2DA3-BQ	1	
79	1517R-18079	M4x6 Round Head Screw	2	
80	SPW-4	M4 Spring Washer	2	
81	PMS-4x10	M4x10 Round Head Screw	2	
82	SPW-4	M4 Spring Washer	2	
83	WS-4	M4 Plan Washer	2	
84	1517R-18084	Inverter <b>VFD007E11A</b>	1	
85	1517R-18085	Key Pad Cable	1	
86	PMS-3x15	M3x15 Round Head Screw	2	
87	1517R-18087	Power Cord	1	
88	1517R-18088	MGB Nylon Cable Glands	1	
89	BH-6 x 25	M6x25 Hex Socket Head Bolt	4	
90	HN-M6	M6 Hexagon Nut	4	
91	BH-6 x 25	M6x25 Hex Socket Head Bolt	4	
92	WS-6	M6 Plan Washer	4	
93	SPW-6	M6 Spring Washer	4	
94	HN-6	M6 Hexagon Nut	4	
95	1517R-18095	M4x10 Hex Socket Head Bolt	5	
96	1517R-18096	Plastic Wiring Duct	5	
97	1517R-18097	RAIL L TS35	2	
98	1517R-18098	Emi Shielding Gasket FSG2-10	1	

12-5-1 Fig-18100 Control Box Diagram

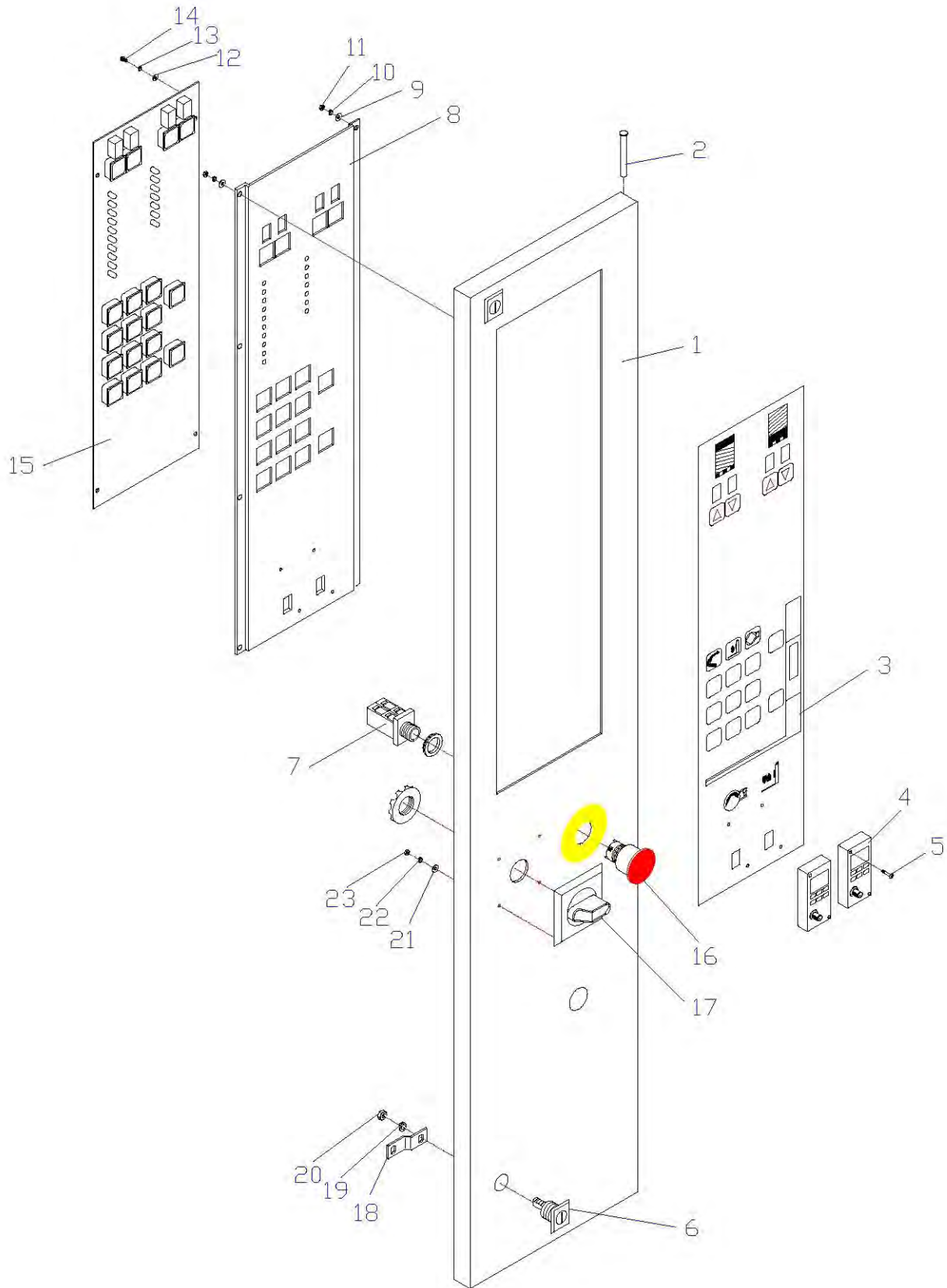

12-5-2 Fig-18100 Control Box Table

Ref.	Part No.	Description	Qty.	Remarks
1	1517-18101	Door for Control Box	1	
2	1517-18102	Snip Pin	2	
3	1517-18103	The Film of the Panel 1518	1	
4	1517-18104	Control Panel of inverter VFD-m	2	
5	1517-18105	M2×15 Round Head Screw	4	
6	1517-18106	Door Lock	2	
7	1517-18107	Emergency Stop Button R9C11	1	
8	1517-18108	Bracket for PC Board	1	
9	1517-18109	M4 Plan Washer	8	
10	1517-18110	M4 Spring Washer	8	
11	1517-18111	M4 Hexagon Nut	8	
12	1517-18112	M4 Plan Washer	6	
13	1517-18113	M4 Spring Washer	6	
14	1517-18114	M4×10 Round Head Screw	6	
15	1517-18115	PCB. KS-050202-key	1	
16	1517-18116	Emergency Stop R2PNP	1	
17	1517-18117	Panel of power switch OHG-2AJ	1	
18	1517-18118	Snip Latch	2	
19	1517-18119	Spring Washer	2	
20	1517-18120	M8 Hexagon Nut	2	
21	1517-18121	M4 Plan Washer	2	
22	1517-18122	M4 Spring Washer	2	
23	1517-18123	M4 Nut	2	
24	1517-18124	VR	1	



# 12-6-1 Fig-19000 Pre-Stretch Unit Diagram

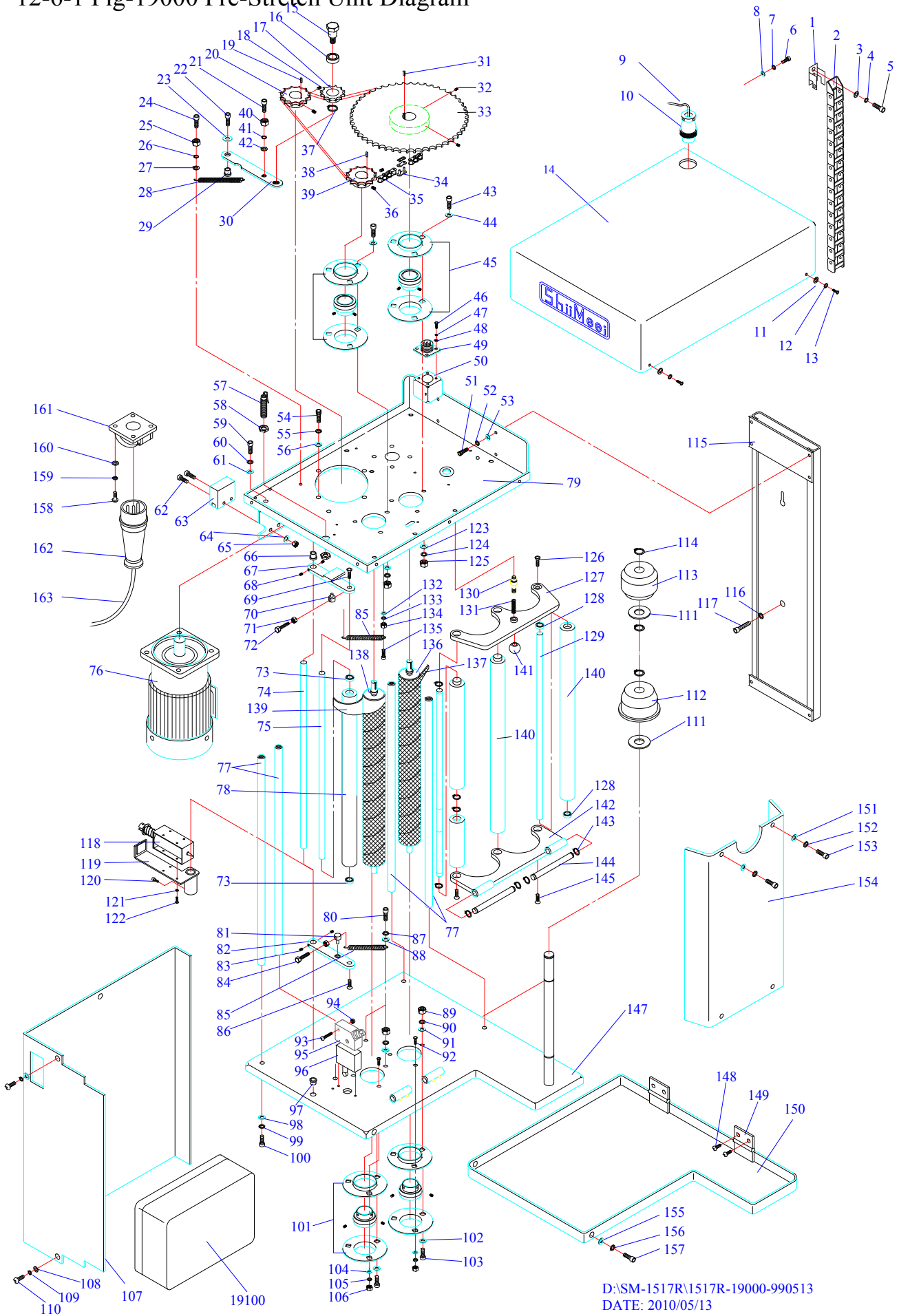

D:\SM-1517R\1517R-19000-990513  
DATE: 2010/05/13

12-6-2 Fig-19000 Pre-Stretch Unit Table (1)

Ref.	Part No.	Description	Qty.	Remarks
1	KYCE-CBC-11C	Fix Plates	2	
2	KYCE-CBC-11	Electric Cable	60	
3	WS-5	M5 Plan Washer	4	
4	SPW-5	M5 Spring Washer	4	
5	CAP-5x10	M5x10 Hexagon Square Head Bolt	4	
6	CAP-M5x15	M5x15 Hexagon Square Head Bolt	2	
7	SPW-5	M5 Spring Washer	2	
8	WS-5	M5 Plan Washer	2	
9	1517R-19009	10P Spring Electric Cable	1	
10	1517R-19010	Socket XS3 2410-RF	1	
11	WS-5	M5 Plan Washer	4	
12	SPW-5	M5 Spring Washer	4	
13	PMS-5x10	M5x10 Round Head Screw	4	
14	1517R-19014	Upper Cover	1	
15	1517R-19015	M10 Screw	1	
16	6903ZZ	6903ZZ Bearing	1	
17	S35-11T-20	#35x11T- $\phi$ 20 Sprocket	1	
18	HSS-6x6	M6x5 Hex Socket Head Set Screw	2	
19	KEY-5x5x20	5x20 Key	1	
20	S35-12T-18-5	#35x12T- $\phi$ 18-5 Sprocket	1	
21	CAP-5x15	M5x15 Hexagon Square Head Bolt	1	
22	CAP-8x30	M8x30 Hexagon Square Head Bolt	1	
23	WS-8	M8 Plan Washer	1	
24	BH5x30	M5x30 Hex Socket Head Bolt	1	
25	HN-5	M5Hexagon Nut	1	
26	SPW-5	M5 Spring Washer	1	
27	WS-5	M5 Plan Washer	1	
28	1517R-19028	Idler Sprocket Tension Spring	1	
29	R-10x12x8	Ring $\phi$ 10x12x $\phi$ 8(D x L x d)	1	
30	1517R-19030	Pressing Arm	1	
31	KEY-5x5x20	5x20 Key	1	
32	HSS-6x6	M6x5 Hex Socket Head Set Screw	2	
33	S35-32T-20-5	#35x32T- $\phi$ 20-5 Sprocket	1	
34	1517R-19034	#35 Chain Link	1	
35	1517R-19035	#35x59L Chain	1	
36	HSS-6x6	M6x5 Hex Socket Head Set Screw	2	
37	RTW-20	"R" Snap Ring $\phi$ 20	1	



12-6-2 Fig-19000 Pre-Stretch Unit Table (2)

Ref.	Part No.	Description	Qty.	Remarks
38	KEY-5x5x20	5x20 Key	1	
39	S35-13T-20-5	#35x13T-20-5 Sprocket	1	
40	HN-5	M5Hexagon Nut	1	
41	SPW-5	M5 Spring Washer	1	
42	WS-5	M5 Plan Washer	1	
43	CAP-8x25	M8x25 Hexagon Square Head Bolt	6	
44	WS-8	M8 Plan Washer	6	
45	BPF-4-	BPF-4 Bearing	2	
46	PMS-3x10	M3x10 Round Head Screw	4	
47	SPW-3	M3 Spring Washer	4	
48	WS-3	M3 Plan Washer	4	
49	LLP 605-24-10P	Plug XP3 2410-PM	1	
50	1517R-19050	Connector Set	1	
51	CAP-6x15	M6x15 Hexagon Square Head Bolt	8	
52	SPW-6	M6 Spring Washer	8	
53	WS-6	M6 Plan Washer	8	
54	CAP-5x20	M5x20 Hexagon Square Head Bolt	1	
55	SPW-5	M5 Spring Washer	1	
56	HN-5	M5 Hexagon Nut	1	
57	9914-0900	PULSO Proximity Switch 9914-0900	1	
58	1517R-19058	Screw Cap for Proximity Switch	2	
59	CAP-8x25	M8x25 Hexagon Square Head Bolt	4	
60	SPW-8	M8 Spring Washer	4	
61	WS-8	M8 Plan Washer	4	
62	PMS-4x30	M4x30 Round Head Screw	2	
63	1517R-19063	FOTEK Photo Sensor FR-2MX	1	
64	SPW-4	M4 Spring Washer	1	
65	HN-4	M4 Hexagon Nut	2	
66	R-10x12x8	Ring $\psi$ 10x12x $\psi$ 8(D x L x d)	1	
67	1517R-19067	Upper Roller Arm	1	
68	HSS-5x5	M5x5 Hex Socket Head Set Screw	2	
69	FMS-8x20	M8x20 Flat Machine Screw	1	
70	1517R-19070	Ouch	1	
71	HN-6	M6Hexagon Nut	1	
72	BH-6x35	M6 Hex Socket Head Bolt	1	
73	6001ZZ	6001ZZ Bearing	2	
74	SH-8-600	$\phi$ 8x 600 L Shaft	1	

12-6-2 Fig-19000 Pre-Stretch Unit Table (3)

Ref.	Part No.	Description	Qty.	Remarks
75	SH-12-525	$\phi$ 12x525 L Shaft	1	
76	1517R-19076	Gear Motor 200/380V 1:3	1	
77	SH-15-565	$\phi$ 15x565 L Shaft	4	
78	R32-520-28	$\phi$ 32x520x $\phi$ 28 Roller (D x L x d)	1	
79	1517R-19078	Upper Bracket	1	
80	BH-5 $\times$ 30	M5x30 Hex Socket Head Bolt	1	
81	1517R-19070	Ouch	1	
82	1517R-19082	Bottom Roller Arm	1	
83	HSS-5x5	M5x5 Hex Socket Head Set Screw	2	
84	BH-6x35	M6 Hex Socket Head Bolt	1	
85	1517R-19028	Idler Roller Tension Spring	1	
86	FMS-8x20	M8x20 Flat Machine Screw	1	
87	HN-5	M5Hexagon Nut	1	
88	SPW-5	M5 Spring Washer	1	
89	HN-8	M8 Hexagon Nut	4	
90	SPW-8	M8 Spring Washer	4	
91	WS-8	M8 Plan Washer	4	
92	FMS-6x25	M6x25 Flat Machine Screw	2	
93	PMS-4x30	M4x30 Round Head Screw	2	
94	HN-4	M4Hexagon Nut	2	
95	TM-1308	Micro Switch	1	
96	AMC-1	Micro Switch Almuce	1	
97	R-10x12x8	Ring $\phi$ 10x12x $\phi$ 8(D x L x d)	1	
98	WS-8	M8 Plan Washer	4	
99	SPW-8	M8 Spring Washer	4	
100	CAP-8x25	M8x25 Hexagon Square Head Bolt	4	
101	BPF-4	BPF-4 Bearing	2	
102	WS-8	M8 Plan Washer	4	
103	CAP-8x25	M8x25 Hexagon Square Head Bolt	4	
104	WS-6	M6 Plan Washer	2	
105	SPW-6	M6 Spring Washer	2	
106	HN-6	M6 Hexagon Nut	2	
107	1517R-19107	Side Cover	1	
108	WS-4	M4 Plan Washer	6	
109	SPW-4	M4 Spring Washer	6	
110	PMS-4 $\times$ 10	M4x10 Round Head Screw	6	
111	1517R-19111	M20 Plan Washer	2	

12-6-2 Fig-19000 Pre-Stretch Unit Table (4)

Ref.	Part No.	Description	Qty.	Remarks
112	1517R-19112	Bottom Casing for Canister	1	
113	1517R-19113	Upper Casing for Canister	1	
114	1517R-19114	"R" Snap Ring $\phi$ 20	3	
115	1517R-19115	Bracket for Pre-stretch Unit	1	
116	1517R-19116	M12 Spring Washer	2	
117	1517R-19117	M12x25 Hexagon Square Head Bolt	2	
118	1517R-19118	Solenoid	1	
119	1517R-19119	Solenoid Set	1	
120	1517R-19120	M6x15 Hexagon Square Head Bolt	2	
121	1517R-19121	M4 Spring Washer	4	
122	1517R-19121	M4x10 Round Head Screw	4	
123	WS-8	M8 Plan Washer	6	
124	SPW-8	M8 Spring Washer	6	
125	CAP-8x25	M8x25 Hexagon Square Head Bolt	6	
126	FMS-8x20	M8x20 Flat Machine Screw	3	
127	1517R-19127	Stockade Roller Arm (Upper)	1	
128	6001ZZ	6001ZZ Bearing	6	
129	SH-12-525	$\phi$ 12x525L Shaft	3	
130	1517R-19130	Pin	1	
131	1517R-19131	Return Spring	1	
132	WS-5	M5 Plan Washer	1	
133	SPW-5	M5 Spring Washer	1	
134	HN-5	M5 Hexagon Nut	1	
135	BH5x30	M5x30 Hex Socket Head Bolt	1	
136	1517R-19136	$\phi$ 50x530 Roller (Without Rubber)	1	
1360	1517R-191360	Roller & Brake Rubber	1	
137	1517R-19137	$\phi$ 50x530 Roller Brake Rubber	1	
138	1517R-19138	$\phi$ 62x530 Roller (Without Rubber)	1	
1380	1517R-191380	Roller & Brake Rubber	1	
139	1517R-19139	$\phi$ 62x530 Roller Brake Rubber	1	
140	R32-520-28	$\phi$ 32x520x $\phi$ 28 Roller (D x L x d)	2	
141	1517R-13008	$\phi$ 25 Plastics Ball	1	
142	1517R-19142	Stockade Roller Arm (Bottom)	1	
143	STW-14	"R" Snap Ring $\phi$ 14	4	
144	SH-14x88	$\phi$ 14x88L Shaft	2	
145	FMS-8x20	M8x20 Flat Machine Screw	3	
146	1517R-19146	None	0	

12-6-2 Fig-19000 Pre-Stretch Unit Table (5)

Ref.	Part No.	Description	Qty	Remarks
147	1517R-19147	Bottom Bracket	1	
148	PMS-4×10	M4x10 Round Head Screw	4	
149	1517R-19149	2" Looseleaf	2	
150	1517R-19150	Security Guard	1	
151	WS-4	M4 Plan Washer	4	
152	SPW-4	M4 Spring Washer	4	
153	PMS-4x10	M4x10 Round Head Screw	4	
154	1517R-19154	Front Cover	1	
155	WS-5	M5 Plan Washer	2	
156	SPW-5	M5 Spring Washer	2	
157	PMS-5x10	M5x15 Round Head Screw	2	
158	WS-4	M4 Plan Washer	4	
159	SPW-4	M4 Spring Washer	4	
160	PMS-4x10	M4×10 Round Head Screw	4	
161	1517R-19161	XP4 Plug CP2031624	1	
162	1517R-19162	XS4 Socket CP0131624	1	
163	1517R-19163	Electric Wire	1	

# 12-7-1 Fig-19100 Pre-Stretch Unit Diagram

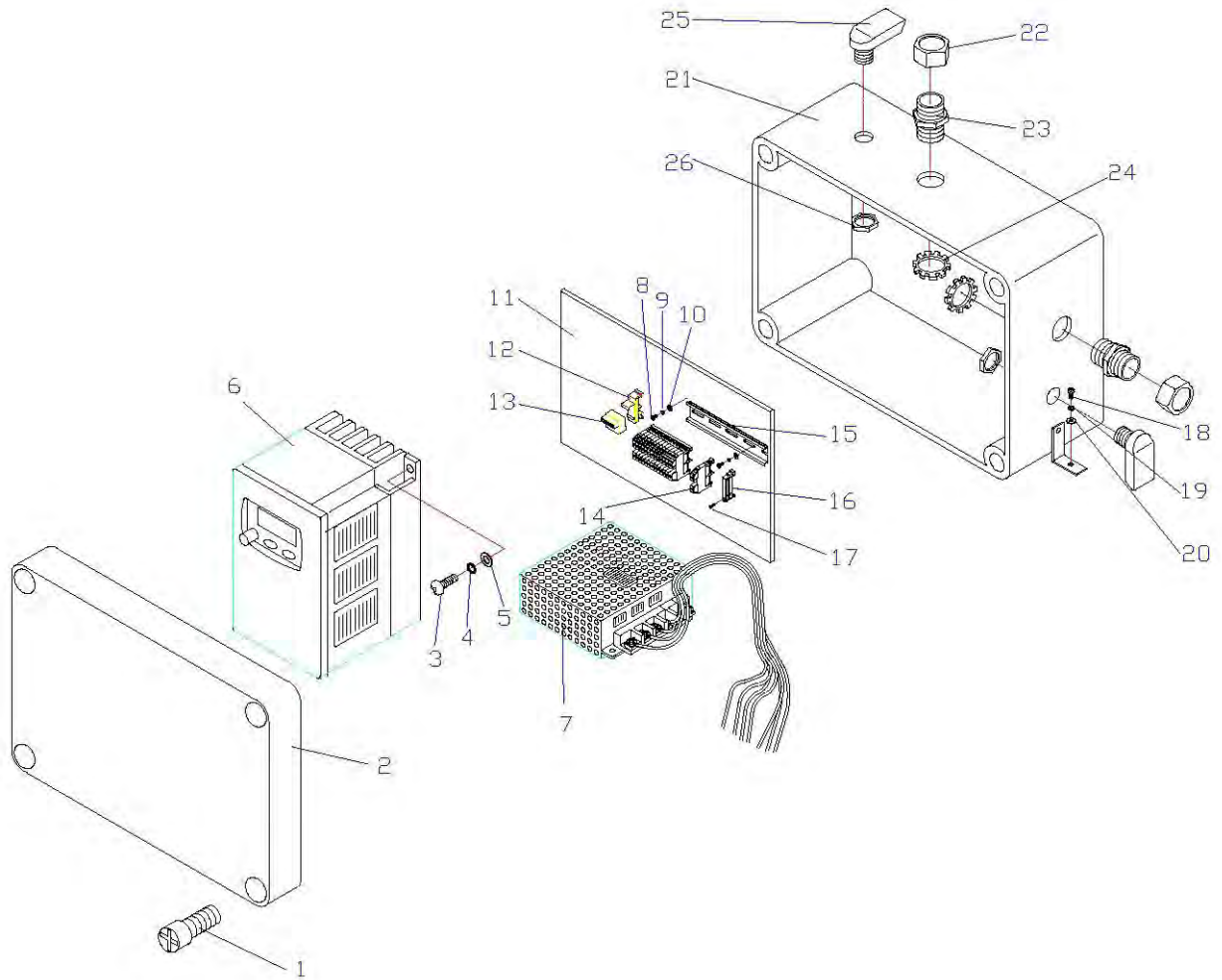

12-7-2 Fig-19100 Pre-Stretch Unit Table

Ref.	Part No.	Description	Qty.	Remarks
1	DSB-25+	Plastics Screw	1	
2	DS-AG-2819C	Casing	1	
3	PMS-5×15	M5x15 Round Head Screw	4	
4	SPW-5	M5 Spring Washer	4	
5	WS-5	M5 Plan Washer	4	
6	1517R-19106	Inverter <b>VFD004E11T</b>	1	
7	NES-15-24	Power Supple	1	
8	SF-4×6	M4×6 Cross Recessed Round Head Screw	2	
9	SPW-4	M4 Spring Washer	2	
10	WS-4	M4 Plan Washer	2	
11	DS-2819	Bottom Base	1	
12	99601	Terminal Block Set	1	
13	997SL	Terminal Block	1	
14	D4/6	Terminal Block M4/6	14	
15	TS-35	Rail TS-35	1	
16	TBRF	End Stop TBRF	1	
17	PMS-4/25×10	4/25x10 Round Head Screw	1	
18	PMS-4×10	M4x10 Round Head Screw	3	
19	SPW-4	M4 Spring Washer	3	
20	WS-4	M4 Plan Washer	3	
21	DS-AG-2819	Junction Box	3	
22	1517-191022	Plastics Hexagon Nut	2	
23	LL305	Junction Box Connect	2	
24	1517-191024	Plastics Hexagon Nut	2	
25	DS-VH-40	Intake	2	
26	1517R-191026	Plastics Hexagon Nut	2	

### 13 Parts List

SM-1517R Manual	1	Unit
Inverter Manual	1	Unit
Tool Box	1	Unit
Ring Bolt		2 Unit
M12 × 25 Hexagon Square Head Bolt		5 Unit
M12 Spring Washer		5 Unit
M12 Plan Washer		5 Unit
R-24-30-12 Ring	2	Unit
Double-side spanner 8 x 10		1 Unit
Double-side spanner 10 x 12		2 Unit
Double-side spanner 11 x 13		1 Unit
L shape spanner 2.5m/m	1	Unit
L shape spanner 3m/m	1	Unit
Double-side spanner 4m/m	1	Unit
L shape spanner 5m/m	1	Unit
L shape spanner 6m/m	1	Unit
L shape spanner 8m/m	1	Unit
L shape spanner 10m/m	1	Unit
Fuse 0.5A		2 Unit
Fuse 1A		2 Unit
Fuse 2A		2 Unit
Fuse 2.5A		2 Unit



Products Certified By

## LIMITED WARRANTY

Vestil Manufacturing Corporation ("Vestil") warrants this SWA-60 semi-automatic stretch wrapping machine to be free of defects in material and workmanship during the warranty period. Our warranty obligation is to provide a replacement for a defective original part if the part is covered by the warranty, after we receive a proper request from the warrantee (you) for warranty service.

### Who may request service?

Only a warrantee may request service. *You are a warrantee if* you purchased the product from Vestil or from an authorized distributor AND Vestil has been fully paid.

### What is an "original part"?

An original part is a part used to make the product as shipped to the warrantee.

### What is a "proper request"?

A request for warranty service is proper if Vestil receives: 1) a photocopy of the Customer Invoice that displays the shipping date; AND 2) a written request for warranty service including your name and phone number. Send requests by any of the following methods:

<u>Mail</u>	<u>Fax</u>	<u>Email</u>
Vestil Manufacturing Corporation 2999 North Wayne Street, PO Box 507 Angola, IN 46703	(260) 665-1339 <u>Phone</u> (260) 665-7586	sales@vestil.com

In the written request, list the parts believed to be defective and include the address where replacements should be delivered.

### What is covered under the warranty?

After Vestil receives your request for warranty service, an authorized representative will contact you to determine whether your claim is covered by the warranty. Before providing warranty service, Vestil may require you to send the entire product, or just the defective part or parts, to its facility in Angola, IN. The warranty covers defects in the following *original* dynamic components: motors, hydraulic pumps, electronic controllers, switches and cylinders. It also covers defects in *original* parts that wear under normal usage conditions ("wearing parts"): bearings, hoses, wheels, seals, brushes, batteries, and the battery charger.

### How long is the warranty period?

The warranty period for original components is 90 days. The warranty period begins on the date when Vestil ships the product to the warrantee. If the product was purchased from an authorized distributor, the period begins when the distributor ships the product. Vestil may extend the warranty period for products shipped from authorized distributors by *up to* 30 days to account for shipping time.

### If a defective part is covered by the warranty, what will Vestil do to correct the problem?

Vestil will provide an appropriate replacement for any *covered* part. An authorized representative of Vestil will contact you to discuss your claim.

### What is not covered by the warranty?

1. Labor;
2. Freight;
3. Occurrence of any of the following, which automatically voids the warranty:
  - Product misuse;
  - Negligent operation or repair;
  - Corrosion or use in corrosive environments;
  - Inadequate or improper maintenance;
  - Damage sustained during shipping;
  - Collisions or other incidental contacts causing damage to the product;
  - Unauthorized modifications: DO NOT modify the product IN ANY WAY without first receiving written authorization from Vestil. Modification(s) might make the machine unsafe to use or might cause excessive and/or abnormal wear.

### Do any other warranties apply to the product?

Vestil Manufacturing Corp. makes no other express warranties. All implied warranties are disclaimed to the extent allowed by law. Any implied warranty not disclaimed is limited in scope to the terms of this Limited Warranty.

