

SEMI-AUTOMATIC STRETCH WRAP MACHINE - SWA-70

APPROX WEIGHT: 970.81 lbs.
DOES NOT INCLUDE WEIGHT OF POWER OR PACKAGING!!!

*** ANY ADDITIONS, DELETIONS, OR OMISSIONS MUST BE CORRECTED ON THIS DRAWING AS THIS DRAWING WILL BE CONSIDERED ALL INCLUSIVE ***

ALL GRAPHICS PROVIDED ARE FOR REFERENCE ONLY. IF CERTAIN DIMENSIONS ARE CRITICAL PLEASE VERIFY THOSE DIMENSIONS WITH YOUR SALESPERSON

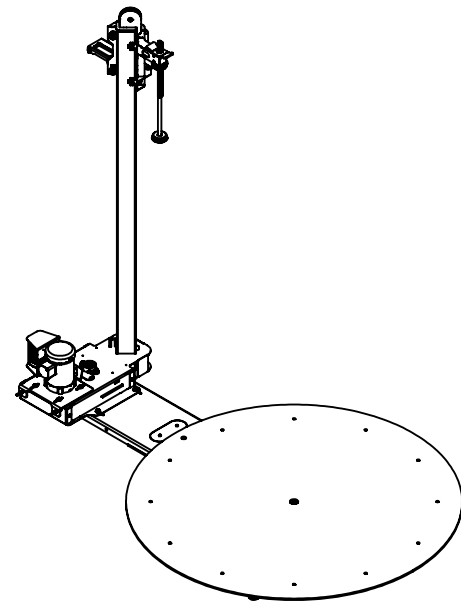
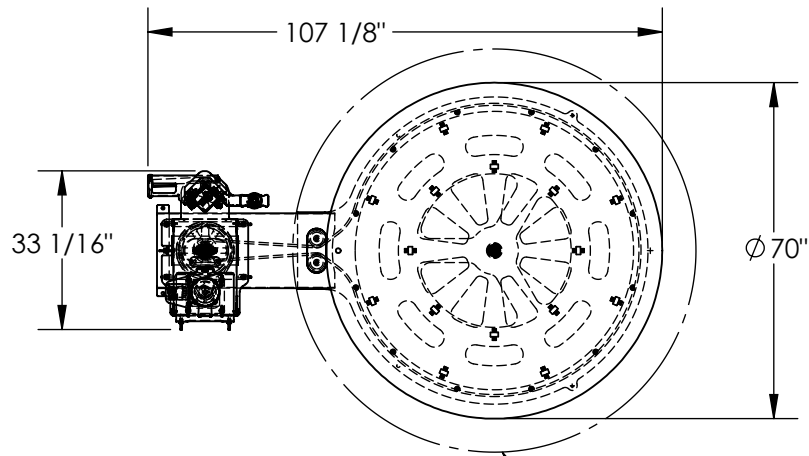

3-D VIEW FOR REFERENCE

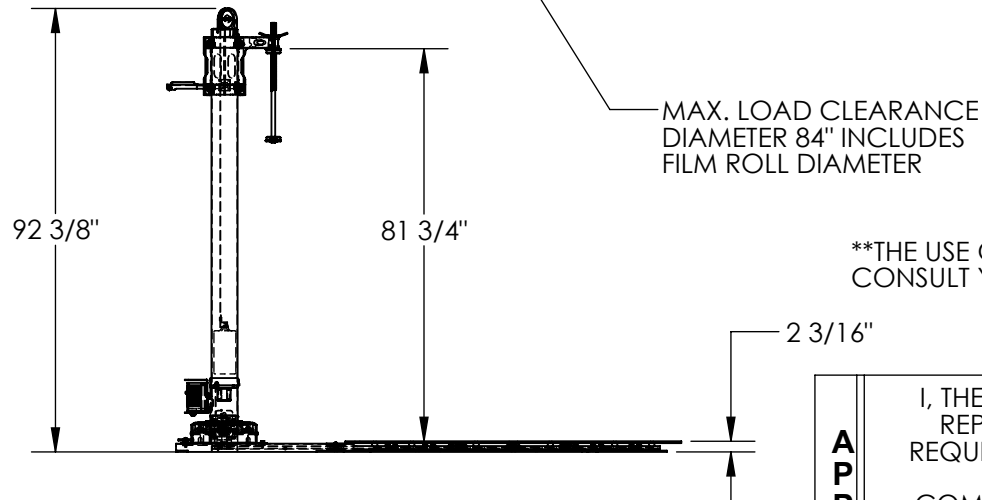

**THE USE OF A GFCI WILL REQUIRE THE USE OF A LINE-REACTOR
CONSULT YOUR LOCAL ELECTRICAL SUPPLIER FOR DETAILS**

DIMENSION TOLERANCE $\pm 1/4$ "

STANDARD FEATURES

- MODEL NUMBER: SWA-70
- CAPACITY: 4000 LBS.
- TURN TABLE DIAMETER: 70"
- OVERALL LENGTH: 107 1/8"
- OVERALL HEIGHT: 92 3/8"
- MAX WRAP HEIGHT: 81 3/4"
- POWER INPUT IS 115 V 1-PHASE
- TURN TABLE DECK HEIGHT: 2 3/16"
- BELT DRIVEN
- VARIABLE SPEED TURN TABLE (3 - 12 RPM)
- WITH SOFT START/STOP
- FOOT CONTROL FOR TURN TABLE ROTATION
- DECK IS TOUGH BAKED IN POWDER COAT YELLOW
- FRAME IS TOUGH BAKED IN POWDER COAT BLUE

SPECIAL FEATURES

NONE

APPROVAL

I, THE UNDERSIGNED, AGREE THAT THE PRODUCT AS REPRESENTED SATISFIES DESIGN AND DIMENSION REQUIREMENTS. I ALSO ACKNOWLEDGE MY DUTY TO CONFIRM PRODUCT AND INSTALLATION COMPLIANCE WITH ALL APPLICABLE FEDERAL, STATE AND LOCAL REGULATIONS AND STANDARDS.

UNITS REQUIRING APPROVAL DRAWINGS OR MODIFIED ARE NON-RETURNABLE

[] As drawn [] As marked

Signed: _____ Date: _____

Printed Name: _____

LEAD TIME WILL START UPON RECEIPT OF SIGNED APPROVAL DRAWING

FOR INTERNAL USE ONLY PROJECT SIGN OFF	
SALES	
ENG.	
FAB.	
POWER	

DISTRIBUTOR'S NAME:		P.O.#
VESTIL MANUFACTURING		X
DRAWN BY: SJA	DATE: 2/3/2015	W.O.#
REFERENCE: X	SCALE: 1:40	X
QUOTED LEAD TIME: X	QUOTE #	FILE NAME:
	X	20-007-118