

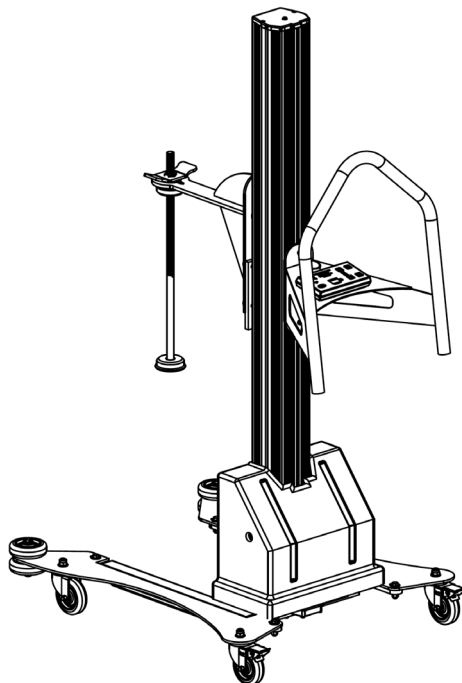

Vestil Manufacturing Corp.
 2999 North Wayne Street, P.O. Box 507, Angola, IN 46703
 Telephone: (260) 665-7586 -or- Toll Free (800) 348-0868
 Fax: (260) 665-1339
 Web: www.vestilmfg.com e-mail: info@vestil.com

PEL-88-A-SWA & PEL-100-A-SWA Wrapping Machines Use and Maintenance Manual



Receiving instructions:

After delivery, remove the packaging from the product. Inspect the product closely to determine whether it sustained damage during transport. If damage is discovered, record a complete description of it on the bill of lading. If the product is undamaged, discard the packaging.

NOTE:

The end-user is solely responsible for confirming that product design, use, and maintenance comply with laws, regulations, codes, and mandatory standards applied where the product is used.

Technical Service and Replacement Parts:

For answers to questions not addressed in these instructions and to order replacement parts, labels, and accessories, call our Technical Service and Parts Department at (260) 665-7586. The department can also be contacted online at http://www.vestilmfg.com/parts_info.htm.

Table of Contents

Specifications.....	2
Signal Words.....	2
Hazards.....	3
PEL-88-A-SWA Exploded View & Bill of Materials.....	4, 5
Electric Circuit Diagram.....	5
PEL-100-A-SWA Exploded View & Bill of Materials.....	6, 7
Labeling Diagram.....	7
Loading Stretch Wrap.....	8
Using the Machine.....	8
System Power and Charging the Batteries.....	9
Record of Original Condition.....	9
Inspections & Maintenance.....	9
Troubleshooting.....	10
Limited Warranty.....	11

Specifications

Dimensions, net weight, and other product specifications appear in the diagrams and table below. Machine design is subject to change without notice, so the appearance of your machine might differ slightly from these illustrations. Compare the diagrams and net weight figure to the "Approval Drawing" you were given when you purchased the machine. If the approval drawing differs from these illustrations, the drawing should be regarded as correct.

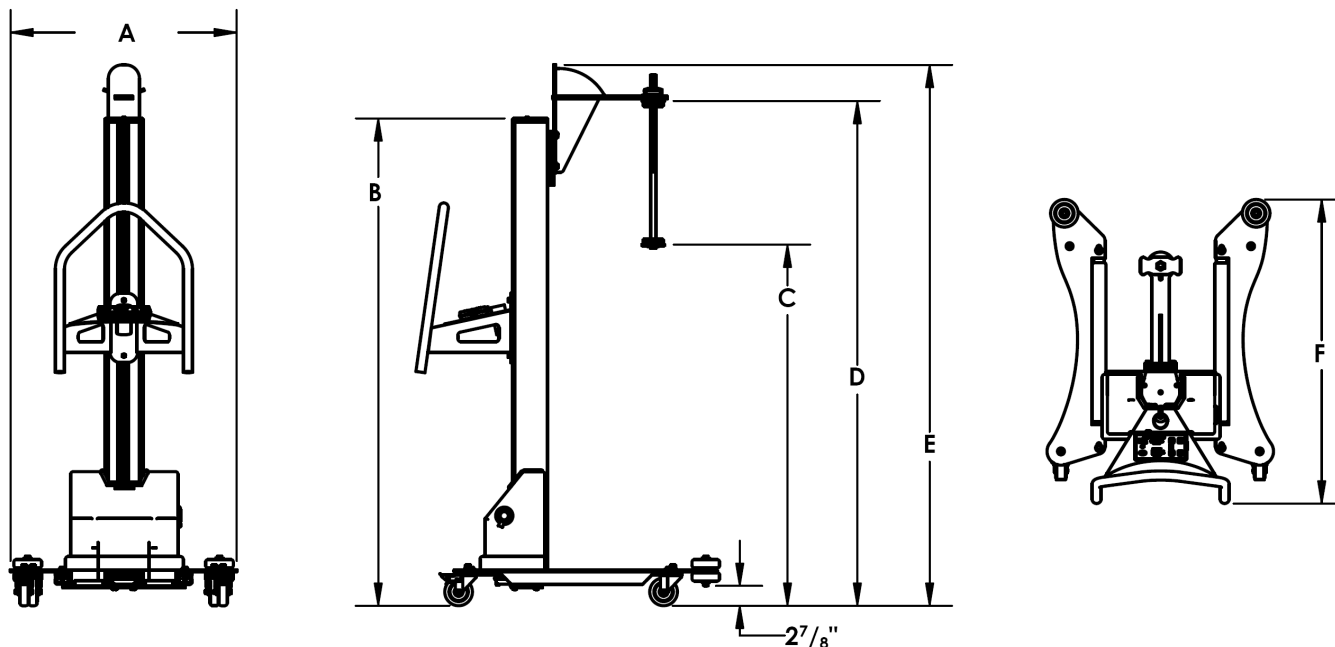

Model	A	B	C	D	E	F	Net weight
PEL-88-A-SWA	32 ³ / ₄ in. 83.2 cm	70 ³ / ₈ in. 178.8 cm	52 ¹ / ₈ in. 132.4 cm	72 ⁷ / ₈ in. 185.1 cm	78 ¹ / ₈ in. 198.4 cm	43 ⁷ / ₈ in. 111.4 cm	206 lb. 93.6 kg
PEL-100-A-SWA	32 ³ / ₄ in. 83.2 cm	85 ¹ / ₈ in. 216.2 cm	67 ³ / ₁₆ in. 170.7 cm	88 ¹ / ₁₆ in. 223.7 cm	93 ¹ / ₈ in. 236.5 cm	43 ⁷ / ₈ in. 111.4 cm	214 lb. 97.3 kg

Signal Words

This manual classifies personal injury risks and situations that might cause property damage with signal words. Signal words indicate the seriousness of injuries that might result if a particular act does, or does not, occur.



DANGER Identifies a hazardous situation which, if not avoided, WILL result in DEATH or SERIOUS INJURY. Use of this signal word is limited to the most extreme situations.



WARNING Identifies a hazardous situation which, if not avoided, COULD result in DEATH or SERIOUS INJURY.



CAUTION Indicates a hazardous situation which, if not avoided, COULD result in MINOR or MODERATE injury.



NOTICE Identifies practices likely to result in product/property damage, such as operation that might damage the product.

Hazards

We strive to identify all hazards associated with the use of our products. However, material handling is dangerous and no manual can address every risk. The most effective way to avoid injury is for the end-user to exercise sound judgment whenever using this product.

- ⚠ WARNING** Material handling is dangerous. Improper or careless operation of this wrapping machine might result in death or serious personal injuries.
- **Read the entire manual and understand it before assembling, using, or servicing the product.** Read the manual whenever necessary to refresh your understanding of use, stretch wrap reloading, and maintenance procedures.
 - DO NOT use the wrapping machine unless it is in original condition. Inspect the unit as described in the [Inspections & Maintenance](#) instructions on p. 9 to determine whether it is functioning normally. DO NOT use the machine unless it passes every part of the inspection or until it is restored to normal operating condition.
 - Always watch the carriage carefully while raising and lowering it.
 - This machine is specially adapted for applying stretch wrap. DO NOT lift items with the carriage. DO NOT push or pull items with the machine. DO NOT use the machine to lift anything but properly loaded stretch wrap.
 - DO NOT stand on the machine or ride on it.
 - Load the wrapping material and set tension appropriately. See [Loading Stretch Wrap](#) on p. 8. If tension is too great, or if the user suddenly jerks the wrapping rather than steadily pulling it from the roll, the machine might fall over.
 - ONLY install manufacturer-approved replacement parts to repair the machine.
 - The carriage should elevate and lower smoothly. Watch for binding or jerky movement and listen for unusual noises. Remove the unit from service if you observe anything abnormal.
 - DO NOT use this wrapping machine UNLESS all labels are in place, undamaged, and easily readable. See [Labeling Diagram](#) on p. 7.
 - DO NOT modify this product in any way. Modifying the machine automatically voids the [Limited Warranty](#) and might make it unsafe to use.

NOTICE Proper use and maintenance are essential for this product to operate correctly for as long as possible.

- Always use this product in accordance with the instructions in this manual.
- Periodically clean the machine and lubricate moving parts.
- Keep the product dry at all times. Always store the unit inside. Do not use outside if it is snowing, raining, etc.
- Only use approved replacement parts. To order replacement or spare parts for this equipment, contact the [Parts Department](#).

PEL-88-A-SWA Exploded View
 [NOTE: Bill of Materials on Following Page]

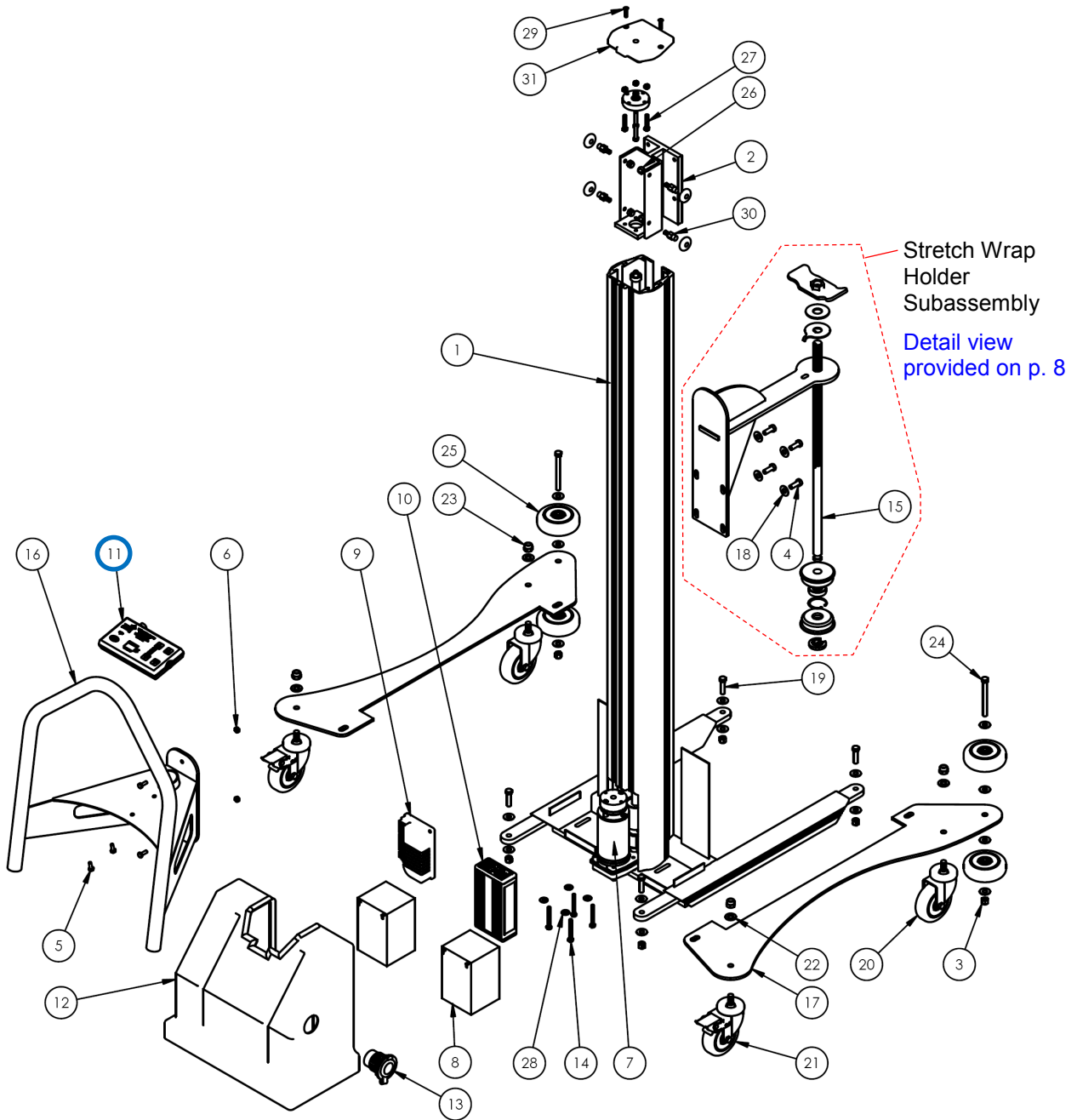

Item 11: Touchpad control

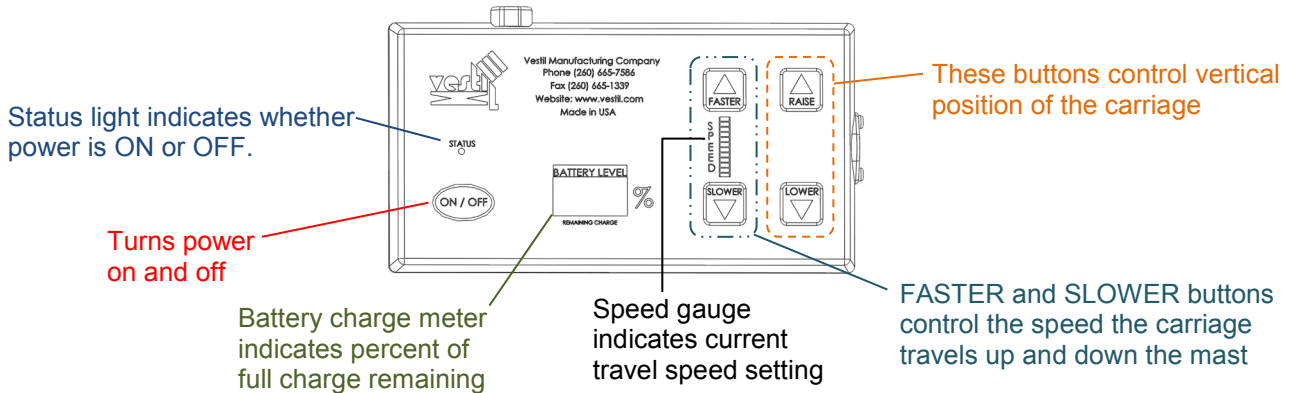

PEL-88-A-SWA Bill of Materials

Item	Part no.	Description	Quantity	Item	Part no.	Description	Quantity
1	42-514-002	Weldment, frame [NOTE: upright portion called "mast"]	1	17	20-016-076	Bracket, roller	2
2	42-538-001	Weldment, carriage	1	18	33008	3/8in. flat washer	20
3	37024	3/8in.-16 Nylock insert nut	6	19	11109	3/8in. - 16 x 1 1/2in. HHCS #2 zinc-plated bolt	4
4	11105	3/8in. - 16 x 1in. hex head bolt	4	20	16-132-155	Caster, swivel, stem, HR-4/1.25-SLB-S	2
5	11003	1/4in. - 20 x 3/4in. hex head bolt	4	21	16-132-156	Caster, swivel, with brake, HR-4-1.25-SLB-S	2
6	37018	1/4in. - 20 lock nut	6	22	33011	1/2in. flat washer	4
7	21-641-008	Assembly, screw drive	1	23	37030	1/2in. - 13 Nylock nut	4
8	21-139-001	12V battery	2	24	11119	3/8in. - 16 x 4in. HHCS #2 zinc-plated hex head bolt	2
9	21-156-006	Accessories, Electrical control box, Curtis 1210-2401	1	25	16-132-009	PP-4/1.25-W	4
10	21-034-010	24V battery charger	1	26	37021	5/16in. - 18, Nylock nut, zinc	4
11	21-156-002	Electronic touchpad control	1	27	11009	1/4in.-20x1 1/2", bolt. Gr. A, zinc	4
12	21-024-042	Motor cover	1	28	33004	1/4in. flat washer, USS, zinc	4
13	21-034-025	Flanged inlet sleeve with locking ring	1	29	24213	Flat socket head countersunk cap screw #10-32 x 1in.	2
14	11012	1/4in. - 20 x 2 1/4in. HHCS #2 zinc-plated bolt	4	30	42-110-001	Bearing, roller	4
15	20-538-002	Assembly, carriage, stretch wrap carrier	1	31	42-524-001	Subassembly, cover/guard, top cap	1
16	20-525-001	Weldment, handle	1				

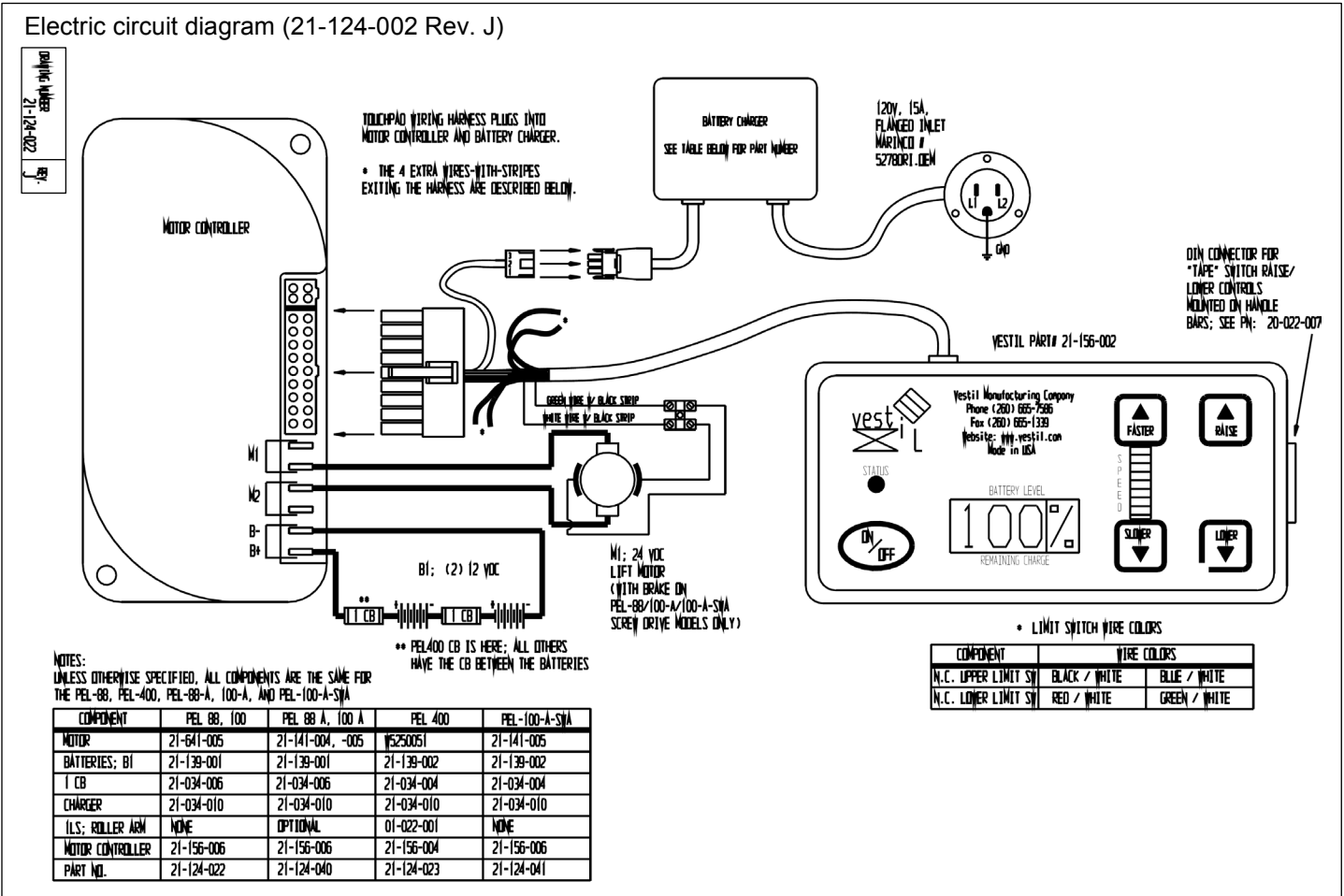

PEL-100-A-SWA Exploded View [NOTE: Bill of Materials on Following Page]

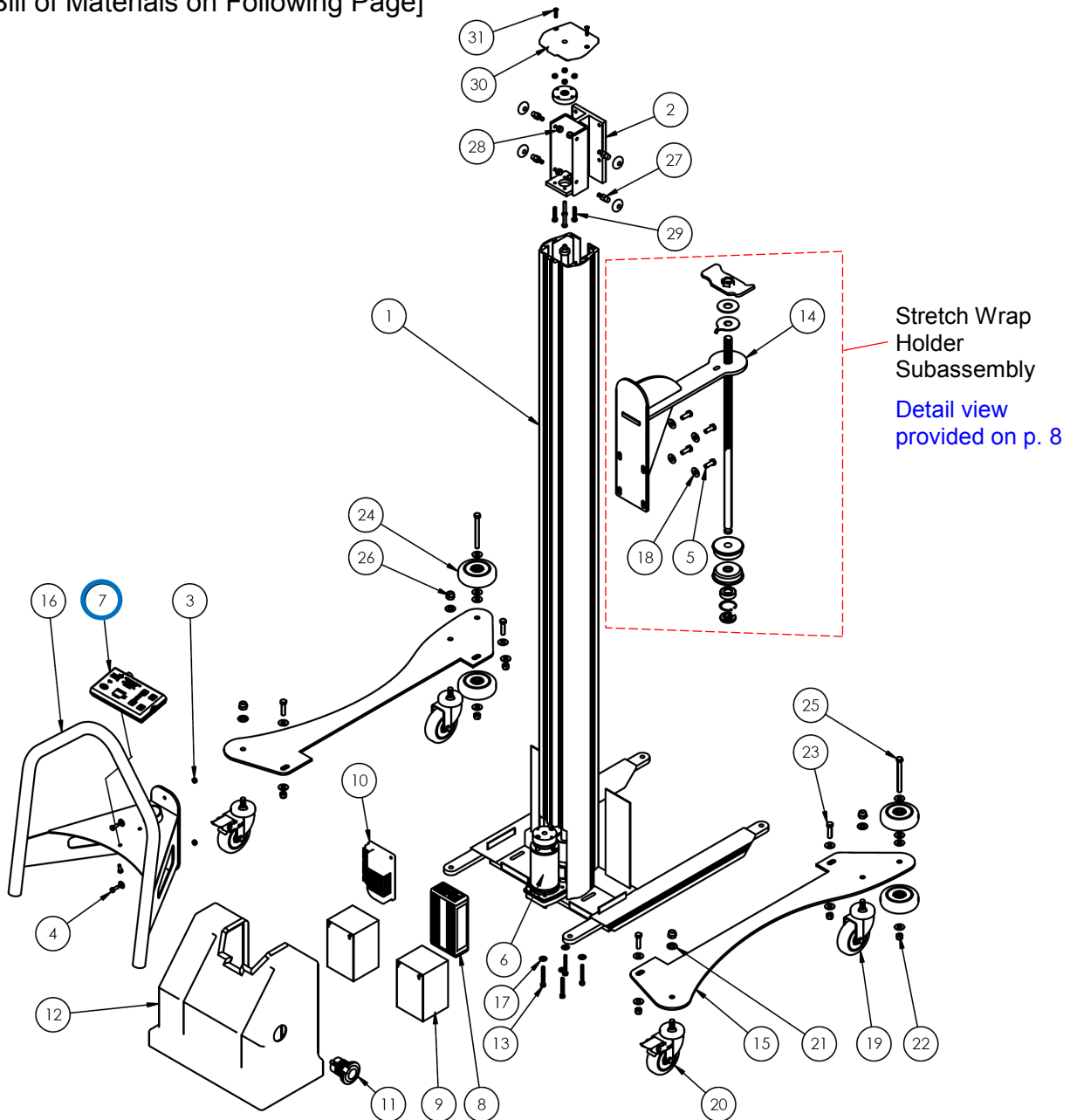

Stretch Wrap Holder Subassembly
Detail view provided on p. 8

Item 7: Touchpad Control

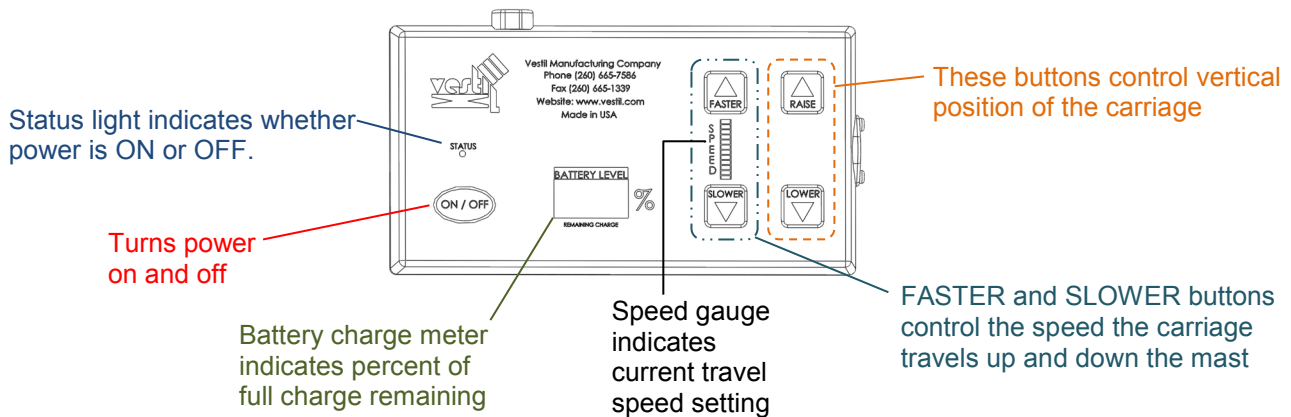

PEL-100-A-SWA Bill of Materials

Item	Part no.	Description	Quantity	Item	Part no.	Description	Quantity
1	42-514-003	Weldment, frame [NOTE: upright portion called "mast"]	1	17	33004	1/4in. flat washer, USS, zinc	6
2	42-538-001	Weldment, carriage	1	18	33008	3/8in. flat washer	20
3	37018	1/4in. – 20 lock nut	6	19	16-132-155	Caster, swivel, stem, HR-4/1.25-SLB-S	2
4	11003	1/4in. – 20 x 3/4in. hex head bolt	4	20	16-132-156	Caster, swivel, with brake, HR-4-1.25-SLB-S	2
5	11105	3/8in. – 16 x 1in. hex head bolt	4	21	33011	1/2in. flat washer	4
6	21-641-009	Assembly, screw drive	1	22	37024	3/8in.-16 Nylock insert nut	6
7	21-156-002	Electronic touchpad control	1	23	11109	3/8in. – 16 x 1 1/2in. HHCS #2 zinc-plated bolt	4
8	21-034-010	24V battery charger	1	24	16-132-009	PP-4/1.25-W	4
9	21-139-001	12V battery	2	25	11119	3/8in. – 16 x 4in. HHCS #2 zinc-plated hex head bolt	2
10	21-156-006	Accessories, Electrical control box, Curtis 1210-2401	1	26	37030	1/2in. – 13 Nylock nut	4
11	21-034-025	Flanged inlet sleeve with locking ring	1	27	42-110-001	Bearing, roller	4
12	21-024-042	Motor cover	1	28	37021	5/16in. – 18, Nylock nut, zinc	4
13	11012	1/4in. – 20 x 2 1/4in. HHCS #2 zinc-plated bolt	4	29	11009	1/4in.-20x1 1/2", bolt. Gr. A, zinc	4
14	20-538-002	Assembly, carriage, stretch wrap carrier	1	30	42-524-001	Subassembly, cover/guard, top cap	1
15	20-016-076	Bracket, roller	2	31	24213	Flat socket head countersunk cap screw #10-32 x 1in.	2
16	20-525-001	Weldment, handle	1				

Labeling diagram

The unit should be labeled as shown in the diagram. However, label content and location are subject to change so your product might not be labeled exactly as shown. Compare this diagram to your *Record of Original Condition*. Replace all labels that are damaged, missing, or not easily readable (e.g. faded). Order replacement labels by contacting the *Replacement Parts Department* online at http://www.vestilmfg.com/parts_info.htm. Alternatively, you may request replacement parts and/or service by calling (260) 665-7586 and asking the operator to connect you to the Parts Department.

A: Label 287

MODEL/MODELO/MODELE	
STATIC CAPACITY (evenly distributed)	_____ lbs.
LA CAPACIDAD CONSTANTE (distribuida uniformemente)	_____ kgs.
CAPACITÉ STATIQUE (distribuée régulièrement)	_____ kgs.
SERIAL/SERIE/SÉRIE	

287 REV 04/18

B: Label 454

Charge unit at least every two weeks or leave plugged in when not in use. Disconnect battery when storing unit without power for more than one month.

Cargue la unidad por lo menos cada dos semanas o enchufado cuando no en uso. Desconecte la batería al salvar la unidad sin carga por más de un mes.

Charger l'unité au moins deux fois par semaine ou laissez branché lorsque la batterie lorsque l'unité est rangée et ne va pas fonctionner pendant plus d'un mois.

VESTIL MANUFACTURING CORP. - Angola, IN 46703 USA
Phone (260) 665-7586 • Fax (260) 665-1339 • www.vestil.com 454

C: Label 208

▲ WARNING KEEP CLEAR OF PINCH POINT	▲ ADVERTENCIA MANTENGASE ALEJADO DEL PUNTO DE CORTE	▲ AVERTISSEMENT SE TENIR À DISTANCE DU POINT DE PINCEMENT
---	---	---

D: Label 212

▲ WARNING LOCK CASTER and/or FLOOR LOCK when loading and unloading	▲ ADVERTENCIA La RUEDECILLA de la CERRADURA y/o el PISO CIERRAN al cargar y descargar	▲ AVERTISSEMENT LOCK CASTER et/ou SOL LOCK lors du chargement et de déchargement
--	---	--

E: Label 527

▲ WARNING

Only trained, authorized persons should operate this device. Improper operation might result in serious personal injuries sustained by the truck operator and/or bystanders. Operators must observe the following safety-enhancing practices:

- **BEFORE** operating, inspect mast, carriage, fork/lock, cab/chair, wheels, and brakes for damage. **DO NOT** use if damaged.
- **ALWAYS** walk travel path before using truck to identify hazards:
 - **DO NOT** contact electrical lines or overhead objects with device or load.
 - **DO NOT** travel up/down inclines if an alternate route is available.
 - **DO NOT** travel over debris.
- **ONLY** travel with fork/lock in lowest position appropriate for conditions.
- **ALWAYS** center and evenly distribute loads on fork/lock.
- **ALWAYS** secure load to fork/lock.
- **ONLY** drive or operate truck functions from operator position.
- **DO NOT** exceed maximum rated load (capacity).
- **DO NOT** allow people to ride on device.
- **DO NOT** lift loads over people. **DO NOT** permit people to walk beneath the fork/lock when raised (loaded or unloaded).
- **DO NOT** leave unattended UNTIL fully lowered AND unloaded.
- **DO NOT** modify device in any way.

▲ ADVERTENCIA

Solo personas entrenadas y autorizadas deben operar este equipo. La operación inadecuada podría resultar en daños serios al operador del camión y/o a los transeúntes. Los operarios deben observar y seguir las siguientes prácticas de seguridad:

- **ANTES** de usar, inspeccione e intente el equipo, las horquillas/plataforma, cables/correa, ruedas y frenos por daños. **NO** use si se observan daños.
- **SIEMPRE** camine el trayecto de viaje antes de usar el camión para identificar riesgos:
 - **NO** toque las líneas eléctricas u objetos arriba con el dispositivo o la carga.
 - **NO** viaje en inclinaciones de subida y bajada si hay otra ruta alternativa.
- **SOLAMENTE** viaje con las horquillas/plataforma en la posición de descenso más apropiada para las condiciones.
- **SIEMPRE** centre y distribuya las cargas uniformemente en las horquillas/plataforma.
- **SIEMPRE** asegure la carga a las horquillas/plataforma.
- **SOLAMENTE** conduzca u opere las funciones del camión desde la posición del operario.
- **NO** exceda la capacidad máxima tasada de carga.
- **NO** permita que la gente viaje en el equipo.
- **NO** levante las cargas sobre la gente. **NO** permita que la gente camine debajo de las horquillas/plataforma cuando está elevada (con carga o sin carga).
- **NO** deje el equipo desatendido **HASTA** que está completamente cargado y descargado.
- **NO** modifique el equipo de ninguna manera.

527-Rev 1/10

F: Label 399 (inside housing)

PEL BATTERY CONNECTIONS

The red wire (from T1 on the motor controller) connects to one side of the circuit breaker. The other side of the circuit breaker connects to the positive (+) post (red) on BAT1.

The short purple wire connects between the BAT1 negative (-) post (black) and BAT2 positive (+) post (red).

The unfused black wire (from T2 on the controller) connects to the negative (-) post (black) on BAT2.

The charger plugs into the quick-connect harness located on the end of the touchpad harness.

CONEXIONES DE LA BATERIA PEL

El alambre rojo (del T1 en el control del motor) se conecta a un lado del interruptor. El otro lado del corte circuito se conecta al poste (rojo) positivo (+) en BAT1.

El alambre de hilo corto morado conecta entre el poste (negro) BAT1 (negativo (-)) y el poste (rojo) BAT2 (positivo (+)).

El alambre negro sin fusible (del T2 en el controlador) se conecta al poste (negro) negativo (-) en el BAT2.

El cargador se enchufa en el equipo de conexión rápida localizado en el extremo del equipo del teclado.

CONEXIONES DE BATTERIE PEL

Le fil rouge (de T1 sur le contrôleur du moteur) se connecte à un côté du disjoncteur. L'autre côté du disjoncteur connecte à l'échelle (borne positive) rouge (+) de BAT1.

Le fil de liaison court connecte entre la batterie BAT1 (négative) négative (-) et la borne BAT2 (positive) rouge (+).

Le chargeur se enchufe dans l'équipement de chargement connecté à la borne négative (-) de BAT2.

Le chargeur de batterie branche à la distribution électrique de la prise de courant située sur le bord de la touche à l'équipement.

VESTIL MANUFACTURING CORPORATION
Angola, Indiana USA
Phone (260) 665-7588 • www.vestil.com
Revision 1003

G: Label 295

▲ WARNING

Enclosed battery contains hazardous chemicals.

DO NOT handle enclosed battery UNLESS wearing eye protection and other appropriate personal protective equipment.

DO NOT directly contact skin with battery.

DO NOT expose to sparks or extreme heat; battery contains explosive gases.

▲ ADVERTENCIA

La batería incluida contiene materiales peligrosos.

NO use la batería incluida A NO SER que lleve protección de ojos y otros equipos de protección apropiados para el personal.

NO tenga contacto directo en la piel con la batería.

NO exponga a destellos o a calor excesivo, la batería contiene gases explosivos.

295
REV 11/11

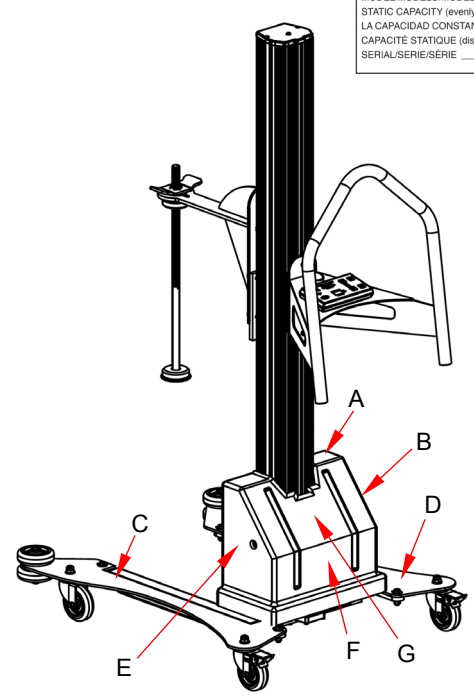

Loading Stretch Wrap

The stretch wrap holder is easily disassembled and reassembled. To load the holder with stretch wrap, follow steps 1-5 below. The holder will accommodate rolls of wrapping material up to 20in. long. [NOTE: Numbers in parentheses () in steps 1-5 below correspond to item numbers in the table.]

Item	Part no.	Description	Qty.	Item	Part no.	Description	Qty.
1	20-113-022	Slotted spacer	1	6	20-014-116	Threaded rod	1
*2	68061	Retaining ring, 1 ⁵ / ₈ "	1	7	20-538-001	Weldment, carriage	1
*3	20-110-002	Assembly, bearing, ball, 3/4" bore	1	8	20-121-001	Formed washer	1
*4	20-014-006	Roll retainer, lower	1	9	20-113-003	Fiber washer	2
5	20-014-005	Roll retainer, upper	1	10	20-620-001	Weldment, rod tension, wing nut	1

* Items 2, 3, & 4 form a "lower roll retainer subassembly" and are already put together.

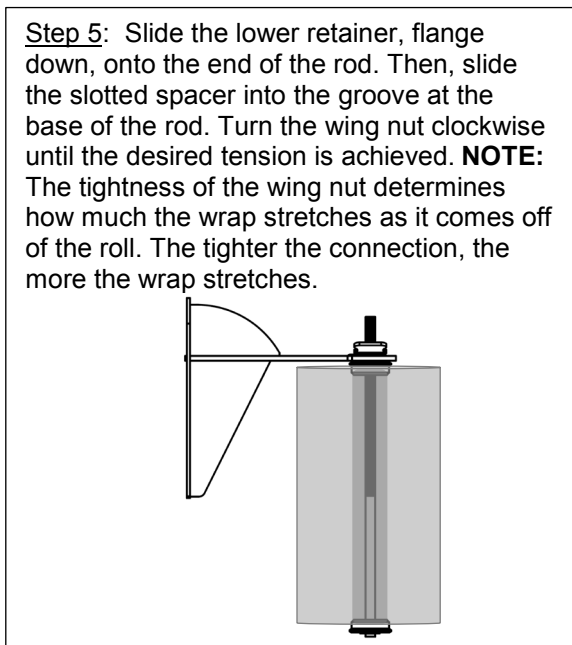
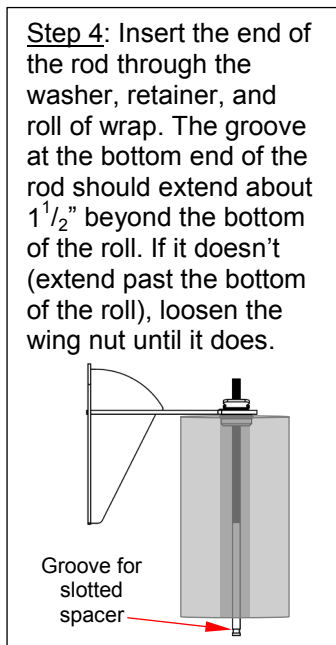
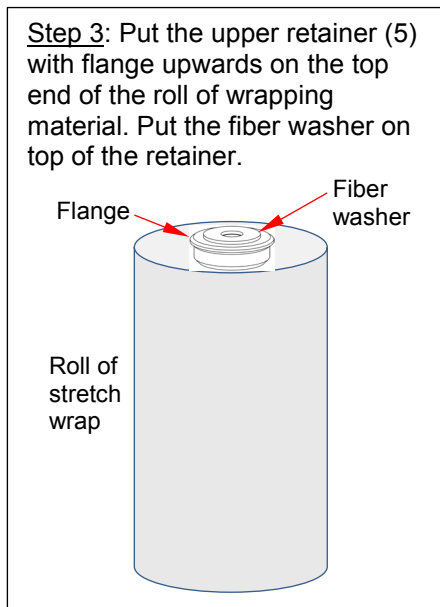
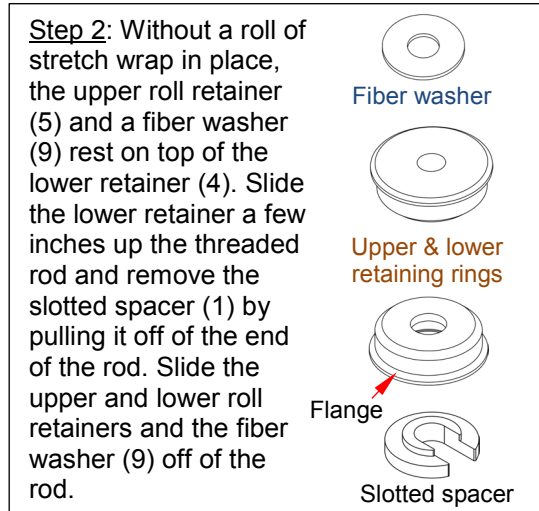
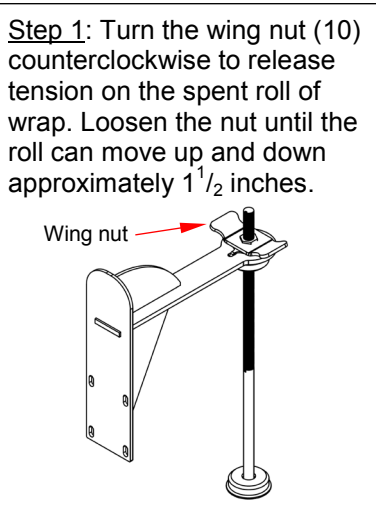
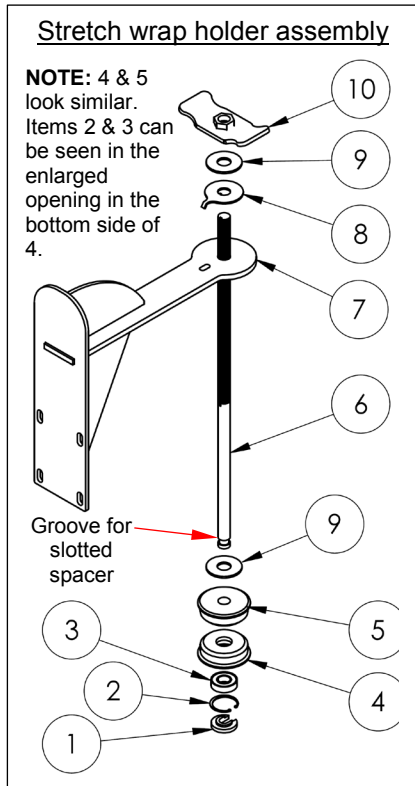

Using the Machine

This machine is not self-propelled. Move the unit by carefully pushing it to the work location.

Carriage travel up and down the mast is controlled electronically via the touchpad. Use the RAISE and LOWER buttons to adjust the vertical position of the carriage as the application requires. Travel speed of the carriage is adjustable. Press the FASTER button to increase travel speed. Press the SLOWER button to decrease speed. A SPEED gauge between the buttons indicates the current (travel) speed setting.

Wrap an item by attaching the free end of the wrap to it. Push the wrapping machine around the object to dispense wrap. When the wrapping process is finished, cut the wrap. Then, lower the carriage, move the machine to its storage location, and apply the caster brakes to immobilize it. See appropriate *Exploded View* on p. 4 or 6.

Store the wrapping machine in a dry, indoor location to protect the electrical and electronic components.

System Power & Charging Batteries

Power is supplied by two 12V batteries. Both batteries are completely sealed and maintenance free.

This wrapping machine includes a 24V charger to recharge the batteries. The charger operates on 115 VAC and requires a 3-prong, grounded extension cord (not included). The charger monitors and reacts to the battery voltage during the recharging process. When the batteries are fully charged, a green LED on the bottom of the charger turns on. See *Battery Charger* diagrams (right). The battery charge gauge displays the amount of battery charge remaining as a percentage of full charge. See *Touchpad control* on page 4 or 6. To determine the true level of charge, wait at least 1/2 hour after turning off the charger. If the voltage is 12.65V or more, then the batteries are fully charged.

Charge the batteries for at least 4 hours before using the wrapping machine for the first time.

How frequently the batteries require charging depends on the load applied to the batteries, i.e. how many times the carriage is moved and how quickly—faster speed will drain the battery more rapidly, and the duration and frequency of use. Experience will indicate when the batteries should be charged.

Recharge batteries until they are fully charged. Do not interrupt the charging cycle. Fully charging the batteries every time recharging is undertaken maximizes battery life.

Recommendations regarding battery charging: 1) Recharge the batteries *at least* once every 2 weeks; 2) Leave the charger plugged in when the unit is not in use (the battery charger can remain connected to the batteries for long periods without causing damage to the batteries); 3) Disconnect the batteries when the unit will not be used for 1 month or longer; and 4) ALWAYS keep the machine dry.

Record of Original Condition

Before putting the unit into service, make a record of its condition and appearance. Thoroughly photograph the unit from multiple angles. Include close range photos of all labels, the touchpad control, the *stretch wrap holder assembly*—particularly the fiber washers, and all casters. Cycle the carriage all the way up and down the mast. Describe the sound of the carriage as it moves. Does the carriage move smoothly up and down the mast? Remove the motor cover. Photograph the internal components (screw drive, battery charger, batteries, electrical control box). Collate all photographs and written descriptions into a single file. This file is a record of the unit in original condition. Compare the results of each inspection to the record to determine whether each component and the unit overall are in original condition. Do not use the machine unless it is in original condition. Purely cosmetic changes are not changes from original condition. However, touchup paint should be applied wherever the finish is damaged as soon as damage occurs.

Inspections & Maintenance

If any of the inspections described below reveal problems, tag the unit “Out of Service”. Restore the machine to normal operating condition BEFORE using it again.

A. Before each use, inspect the following components. Each component must be in normal operating condition. To establish normal operating condition, make a thorough record of the appearance, sound, and function of the various parts of the wrapping machine when you first receive it. Compare later observations to the record to determine whether the machine is in normal operating condition.

1. Frame: Examine the base frame, roller brackets, and handle weldment. Look for damaged welds, warps, cracks, or other deformations.
2. Casters: Examine each caster. Confirm that casters are not severely worn, swivel freely, and that the brakes firmly engage the wheels.
3. Carriage mechanism: Cycle the carriage to the top of the mast and back down. The carriage should move smoothly and at a uniform rate up-and-down the mast. Watch for binding and listen for unusual sounds.
4. Fasteners: Check bolts and nuts. Make sure all fasteners are tight.
5. Roller bearings: Look inside the channel of the mast and examine the roller bearings of the carriage. See *Exploded View*, p. 4 or 6. Clean the interior of the mast to remove debris that might interfere with the rollers.

B. At least once per month:

1. Wiring: Inspect the electrical system and look for loose connections and damage.
2. Clean the machine: Remove dirt and other matter from all surfaces.
3. Labels: Refer to the *Labeling Diagram* on p. 7. Make sure that all labels are in place and easily readable.
4. Batteries: Remove corrosion from the terminal posts.

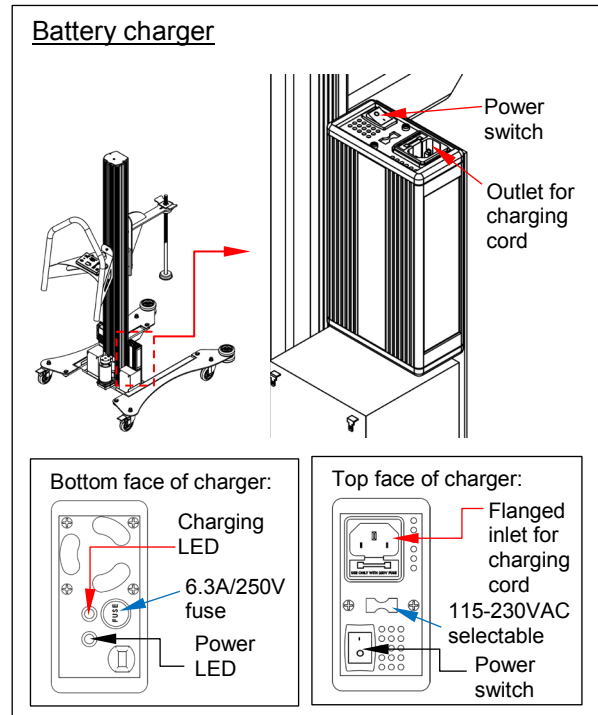

Troubleshooting

The following table describes common issues that occur with these wrapping machines. If your unit experiences a problem not included in this guide, or if you are uncertain whether the machine requires repair, contact the [Technical Service](#) for assistance.

NOTE: The touchpad is not serviceable. DO NOT open the touchpad or attempt to correct a problem you believe might be caused by a touchpad malfunction. Doing so voids the [Limited Warranty](#) (p. 11). Contact [Technical Service](#) to discuss all problems related to the touchpad.

Issue	Explanation	Solution
1) I press the UP or DOWN button on the touchpad but nothing happens.	a. Battery voltage too low. LED flashes: ●●●●● b. Faulty wiring, e.g. broken wire in circuit. c. If using optional hand control, plug loose in touchpad socket. d. Problem with motor or controller. e. Battery charger still plugged into wall socket. f. Circuit breaker or fuse blown.	a. Charge batteries . b. Inspect wiring. Perform circuit continuity checks with meter. See Electric Circuit Diagram on p. 5. c. Unplug hand control and reinsert plug into socket on touchpad. d. See Motor Controller Diagnostics . e. Unplug charger. f. Rest circuit breaker or replace fuse.
2) I press UP or DOWN and can hear the motor humming, but the carriage does not move.	g. Battery voltage is low. h. Load applied to carriage too heavy.	g. Charge battery. h. Reduce load.
3) Carriage stops moving before it reaches fully raised or fully lowered position.	i. Battery voltage is low. j. Roller bearings obstructed or binding. k. Load applied to carriage too heavy.	i. Charge battery. j. Inspect roller track for debris or objects interfering with rollers. k. Examine carriage; reduce load.
4) Touchpad does not respond to any input. LED flashes: ●●	l. Motor temperature either exceeds (>92°C) or below (-25°C) threshold operating temperature.	l. Check load applied to carriage. Reduce, if necessary. Cease use to allow motor to cool. Increase ambient temperature.
5) Touchpad does not respond to any input. LED flashes: ●●● or ●●●● or ●●●●●	m. Throttle input wire open or shorted. n. Throttle pot defective.	m. Check wiring. Confirm all connections are sound. n. Contact factory.
6) Touchpad does not respond to any input. LED flashes: ●●●●	o. Speed limit pot wires broken or shorted. p. Broken speed limit potentiometer.	o. Check wiring. Confirm all connections are sound. p. Contact factory.
7) Touchpad does not respond to any input. LED flashes: ●●●●●	q. Controller failure; low battery voltage.	q. Replace battery.
8) Touchpad does not respond to any input. LED flashes: ●●●●●●	r. Short in motor or in motor wiring. s. Controller failure.	r. Check wiring. Confirm all connections are sound. s. Contact factory.

LIMITED WARRANTY

Vestil Manufacturing Corporation (“Vestil”) warrants this product to be free of defects in material and workmanship during the warranty period. Our warranty obligation is to provide a replacement for a defective, original part covered by the warranty after we receive a proper request from the Warrantee (you) for warranty service.

Who may request service?

Only a warrantee may request service. You are a warrantee if you purchased the product from Vestil or from an authorized distributor AND Vestil has been fully paid.

Definition of “original part”?

An original part is a part used to make the product as shipped to the Warrantee.

What is a “proper request”?

A request for warranty service is proper if Vestil receives: 1) a photocopy of the Customer Invoice that displays the shipping date; AND 2) a written request for warranty service including your name and phone number. Send requests by one of the following methods:

<u>US Mail</u>	<u>Fax</u>	<u>Email</u>
Vestil Manufacturing Corporation 2999 North Wayne Street, PO Box 507 Angola, IN 46703	(260) 665-1339 <u>Phone</u> (260) 665-7586	info@vestil.com Enter “Warranty service request” in subject field.

In the written request, list the parts believed to be defective and include the address where replacements should be delivered. After Vestil receives your request for warranty service, an authorized representative will contact you to determine whether your claim is covered by the warranty. Before providing warranty service, Vestil will require you to send the entire product, or just the defective part (or parts), to its facility in Angola, IN.

What is covered under the warranty?

The warranty covers defects in the following original, dynamic parts: motors, hydraulic pumps, motor controllers, and cylinders. It also covers defects in original parts that wear under normal usage conditions (“wearing parts”), such as bearings, hoses, wheels, seals, brushes, and batteries.

How long is the warranty period?

The warranty period for original dynamic components is 90 days. For wearing parts, the warranty period is 90 days. Both warranty periods begin on the date Vestil ships the product to the Warrantee. If the product was purchased from an authorized distributor, the periods begin when the distributor ships the product. Vestil may, at its sole discretion, extend a warranty period for products shipped from authorized distributors by up to 30 days to account for shipping time.

If a defective part is covered by the warranty, what will Vestil do to correct the problem?

Vestil will provide an appropriate replacement for any *covered* part. An authorized representative of Vestil will contact you to discuss your claim.

What is not covered by the warranty?

The Warrantee (you) is responsible for paying labor costs and freight costs to return the product to Vestil for warranty service.

Events that automatically void this Limited Warranty.

- Misuse;
- Negligent assembly, installation, operation or repair;
- Installation/use in corrosive environments;
- Inadequate or improper maintenance;
- Damage sustained during shipping;
- Collisions or other accidents that damage the product;
- Unauthorized modifications: Do not modify the product IN ANY WAY without first receiving written authorization from Vestil.

Do any other warranties apply to the product?

Vestil Manufacturing Corp. makes no other express warranties. All implied warranties are disclaimed to the extent allowed by law. Any implied warranty not disclaimed is limited in scope to the terms of this Limited Warranty. Vestil makes no warranty or representation that this product complies with any state or local design, performance, or safety code or standard. Noncompliance with any such code or standard is not a defect in material or workmanship.

