

2,000 LBS POWER STACKER PARTS LIST
64"/68" LIFT

POWERED STACKERS

Features:

- Adjustable base legs available on fork models.
- Fixed platforms 24x24, 24x27, 30x32
- Reinforced frame and base.
- Double chain, lift support.
- Heavy-duty pump.
- Ergonomic "D" handles.
- 110V AC models available.

1	051180	HYDRAULIC CYLINDER	1
2	109101	POWER UNIT	1
3	109099	BATTERY	1
4	109104	VOLTMETER	1
5	052782	BATTERY CABLE (NEG.)	1
6	052783	BATTERY CABLE (POS.)	1
7	109150	BATTERY CHARGER	1
8	125824	HYDRAULIC HOSE	1
9	052726	REMOTE CONTROL ASS'Y	1
10	109325	SWITCH	1
11	050782	LIFT CHAIN ASS'Y	2
12	050776	ROLLER CARRIER ASS'Y	2
13	052010	FLOOR LOCK	1
14	053769	WHEEL	2
15	054267	CASTER	2
16	109117	SOLENOID	1

ADJUSTABLE FORK MODELS

Model: PASFL-64-42-3550S-2K
 Lift Height: 64"
 O.A.H: 82"
 Weight: 548
 Capacity: 2000 lbs
 Load Center: 24"
 Fork W/L: 3"/42"
 Base Leg ID/OD: 35"-50" ID ADJ.

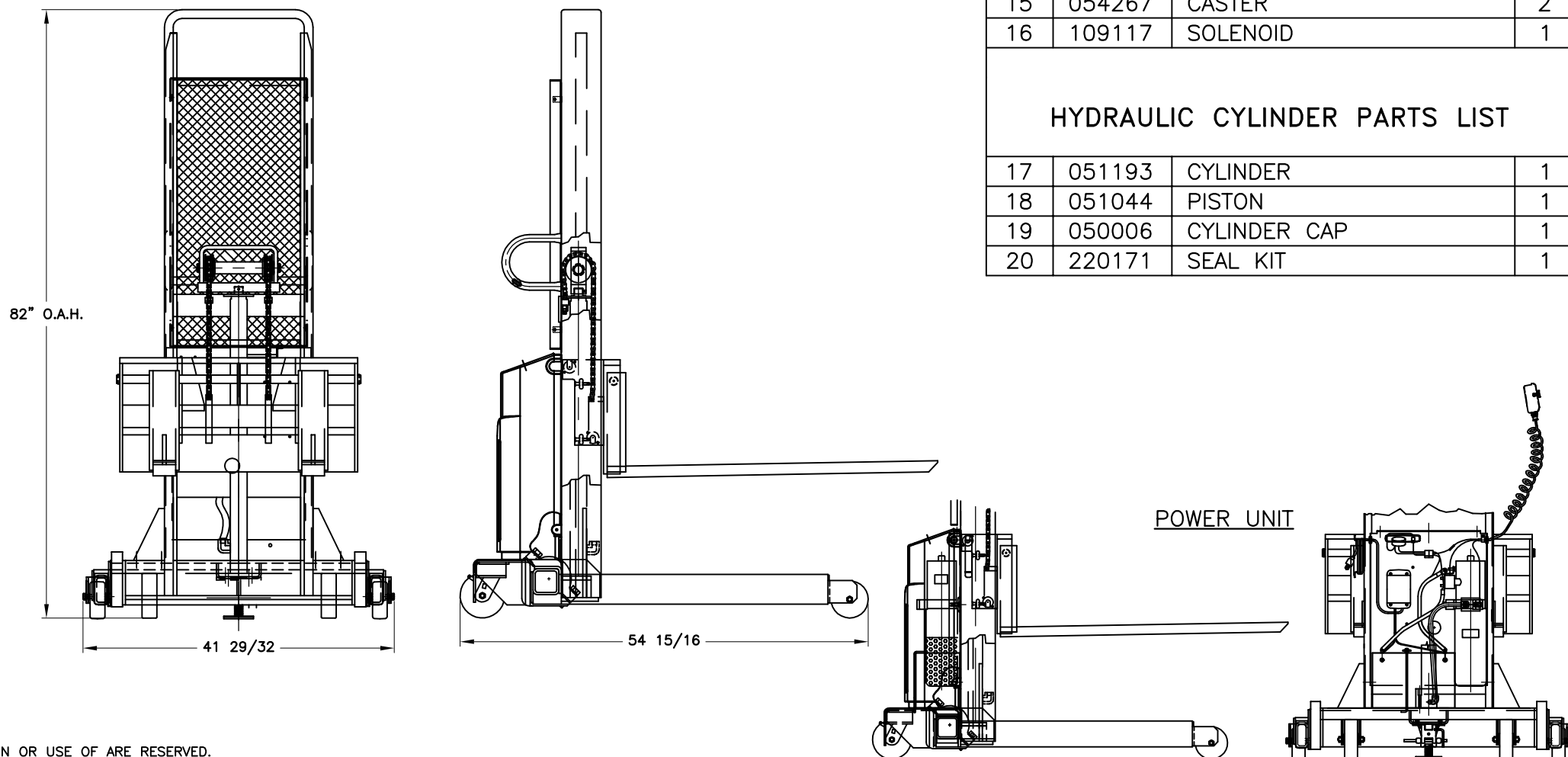

HYDRAULIC CYLINDER PARTS LIST

17	051193	CYLINDER	1
18	051044	PISTON	1
19	050006	CYLINDER CAP	1
20	220171	SEAL KIT	1

THIS DRAWING IN ALL PARTICULARS IS WESCO INDUSTRIAL PRODUCTS INC. PROPERTY. ALL RIGHTS OF DESIGN, INVENTION OR USE OF ARE RESERVED.

PRINT ISSUED
 DEC 06 2007
 WESCO MANUFACTURING
 ENGINEERING DEPARTMENT

WESCO INDUSTRIAL PRODUCTS INC.
 LANSDALE PENNA. 19446

PART NAME PASFL-64-42-3550S-2K

DRAWN: KL 08-07-01
 CHECKED: PS 08-16-01
 APP. ENGR.

TOLERANCE UNLESS OTHERWISE SPECIFIED

FRACTION	3 PLACE DECIMAL	2 PLACE DECIMAL
± 1/64	± .005	± .01

ANGULAR ± 1-1/2' SHEET 1 OF 2

BREAK ALL SHARP EDGES AND REMOVE ALL BURRS

SCALE: 1" = 20"

B-261053

APP
 ECN & DATE
 REVISIONS
 REV.