

261029

POWERED STACKER 1,000 LBS

Features:

- Remote control, floor lock, and safety screen are standard on all models.
- With a minimally charged battery, unit can be used while recharging.
- Easy to read illuminated battery status voltmeter - No extra cost.
- 12V DC battery or 110V AC units available.

FORK MODELS

- Forks lower to floor on all models.
- 5" phenolic wheels on front, 4" swivel on rear.

Model: PESFL-64-25  
 Lift Height: 64"  
 O.A.H 80"  
 Weight: 460 lbs.  
 Leg ID/OD: 15"/21"  
 Capacity: 1,000 lbs.  
 Load Center: 15"

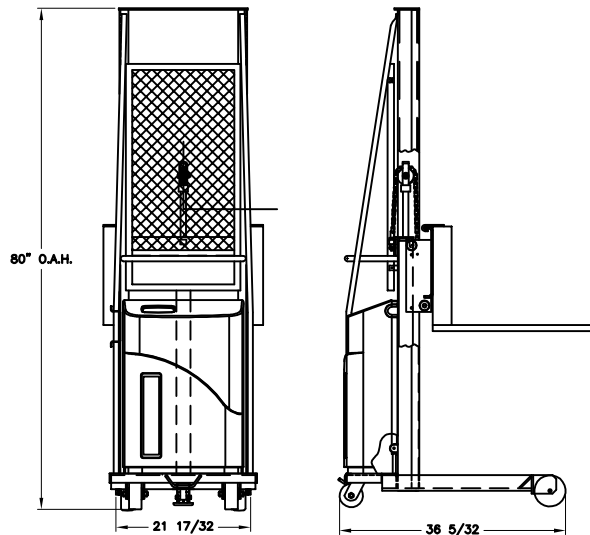

POWER-LIFT STACKER PARTS LIST  
64"/68" LIFT

1	051164	HYDRAULIC CYLINDER	1
2	109101	POWER UNIT	1
3	109102	BATTERY	1
4	109104	VOLTMETER	1
5	052779	BATTERY CABLE (NEG.)	1
6	052780	BATTERY CABLE (POS.)	1
7	109150	BATTERY CHARGER	1
8	125824	HYDRAULIC HOSE	1
9	052726	REMOTE CONTROL ASS'Y	1
10	109325	SWITCH	1
11	050771	LIFT CHAIN ASS'Y	1
12	260143	ROLLER CARRIER ASS'Y	1
13	150001	FLOOR LOCK	1
14	053769	WHEEL	2
15	054265	CASTER	2
16	109117	SOLENOID	1

HYDRAULIC CYLINDER PARTS LIST

17	051073	CYLINDER	1
18	051196	PISTON	1
19	051198	CYLINDER CAP	1
20	220170	SEAL KIT	1

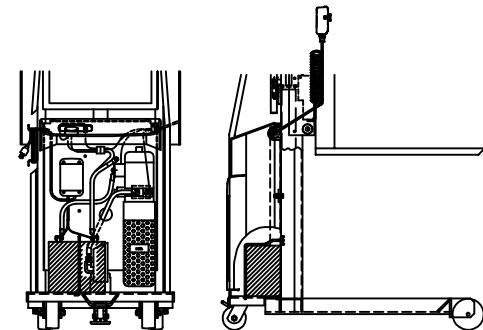

POWER UNIT

THIS DRAWING IN ALL PARTICULARS IS WESCO INDUSTRIAL PRODUCTS INC. PROPERTY. ALL RIGHTS OF DESIGN, INVENTION OR USE OF ARE RESERVED.

PRINT ISSUED  
 DEC 06 2007  
 WESCO MANUFACTURING  
 ENGINEERING DEPARTMENT

REV.	ECN & DATE	REVISIONS	APP		WESCO INDUSTRIAL PRODUCTS INC. LANSDALE PENNA. 19446	
			PART NAME		DRAWN: KL 08-07-01	
			PESFL-64-25		CHECKED: PS 08-16-01	
			TOLERANCE UNLESS OTHERWISE SPECIFIED		APP. ENGR.	
FRACTION		3 PLACE DECIMAL	2 PLACE DECIMAL	SCALE: 1" = 20"		
± 1/64		± .005	± .01	SHEET 1 OF 2		
ANGULAR ± 1-1/2°		BREAK ALL SHARP EDGES AND REMOVE ALL BURRS		B- 261029		