

RNR MACHINERY MOVERS

IF CUSTOMER NEEDS A REPLACEMENT JACK, THEY MUST ORDER THE 270429 KIT

Features:

- Heavy duty capacities up to 5 tons – the most economical way to lift and move large bulky loads.
- Swivel casters allow movement in any direction.
- Hand operated hydraulic jack for easy lifting and controlled lowering of loads.
- All models supplied with hooks for recommended optional LB-1 or LB-2 load binders.

Model RNR-2P
Lift: 5"
Weight: 176 lbs/pair
Casters: 5" X 2"
 Polyurethane
Capacity: 2,000 lb/pair

OD Fork
Span Range: 7.25" to 17.5"

REPLACEMENT PARTS LIST

ITEM	P/N	DESCRIPTION	QTY
1	270429	KIT: REPLACEMENT JACK NEW	2
2	108149	SCREW: HEX HD CAP (5/16-18X1)	4
3	100170	WASHER: LOCK 5/16 MED SPLIT	4
4	100069	WASHER: FLAT (PLTD) 5/16 SAE	4
5	108841	CASTER, 5" x 2" POLY WHL	4
6	109642	BOLT: CARRIAGE 3/8-16X1"	16
7	108201	WASHER: FLAT (PLTD) 3/8" USS	16
8	100217	WASHER: LOCK (PLTD) 3/8"	16
9	100642	NUT: HEX (PLTD) 3/8-16	16
10	106172	TUBING: FLEXO	2
11	106167	STRIP: RUBBER	2
12	051717	HANDLE: JACK (R-N-R)	1
OPTION: LOAD BINDER ACCESSORY			
	260096	LB-1 LOAD BINDER SET W/ DELTA RINGS	1
	260147	LB-2 LOAD BINDER SET W/ "E" TRACK HOOKS	1

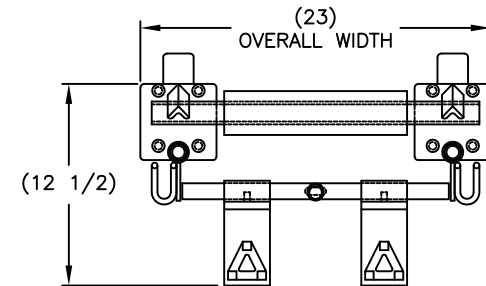
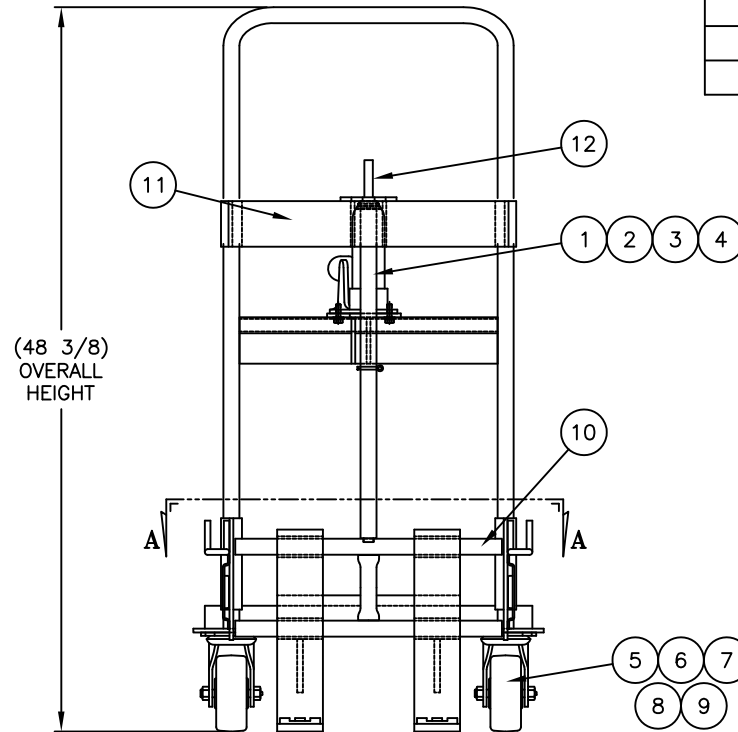
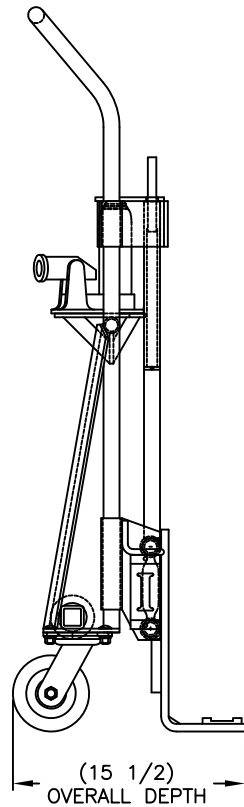

SECTION A-A

THIS DRAWING IN ALL PARTICULARS IS WESCO INDUSTRIAL PRODUCTS, LLC PROPERTY. ALL RIGHTS OF DESIGN, INVENTION OR USE OF ARE RESERVED.

PRINT ISSUED

DEC 29, 2004

WESCO MANUFACTURING
ENGINEERING DEPARTMENT

REV. ECH & DATE	APP.	WESCO INDUSTRIAL PRODUCTS, LLC		APP.
	REVISIONS	NORTH WALES PENNA. 19454		APP. ENGR.
		PART NAME RNR-2P		SCALE:
		TOLERANCE UNLESS OTHERWISE SPECIFIED		C- 260091
		FRACTION	3 PLACE DECIMAL	
		± 1/64	± .005	± .01
		ANGULAR ± 1-1/2°		SHEET 1 OF 1
		BREAK ALL SHARP EDGES AND REMOVE ALL BURRS		REV