

# RNR MACHINERY MOVERS

IF CUSTOMER NEEDS A REPLACEMENT JACK, THEY MUST ORDER THE 270429 KIT

**Features:**

- Heavy duty capacities up to 5 tons – the most economical way to lift and move large bulky loads.
- Swivel casters allow movement in any direction.
- Hand operated hydraulic jack for easy lifting and controlled lowering of loads.
- All models supplied with hooks for recommended optional LB-1 or LB-2 load binders.

**Model** RNR-2  
**Lift:** 5"  
**Weight:** 160 lbs/pair  
**Casters:** 5" X 2"  
 Phenolic  
**Capacity:** 2,000 lb/pair  
  
**OD Fork**  
**Span Range:** 7.25" to 17.5"

## REPLACEMENT PARTS LIST

ITEM	P/N	DESCRIPTION	QTY
1	270429	KIT: REPLACEMENT JACK NEW	2
2	108149	SCREW: HEX HD CAP (5/16-18X1)	4
3	100170	WASHER: LOCK 5/16 MED SPLIT	4
4	100069	WASHER: FLAT (PLTD) 5/16 SAE	4
5	054267	CASTER, 5" x 2" PHENOLIC WHL	4
6	109642	BOLT: CARRIAGE 3/8-16X1"	16
7	108201	WASHER: FLAT (PLTD) 3/8" USS	16
8	100217	WASHER: LOCK (PLTD) 3/8"	16
9	100642	NUT: HEX (PLTD) 3/8-16	16
10	106172	TUBING: FLEXO	2
11	106167	STRIP: RUBBER	2
12	051717	HANDLE: JACK (R-N-R)	1
OPTION: LOAD BINDER ACCESSORY			
	260096	LB-1 LOAD BINDER SET W/ DELTA RINGS	1
	260147	LB-2 LOAD BINDER SET W/ "E" TRACK HOOKS	1

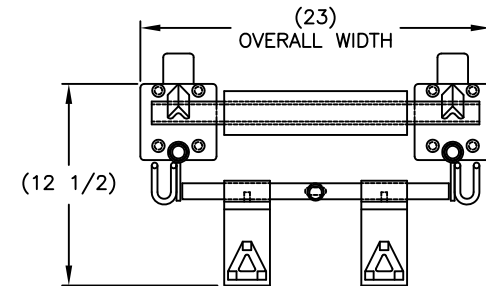
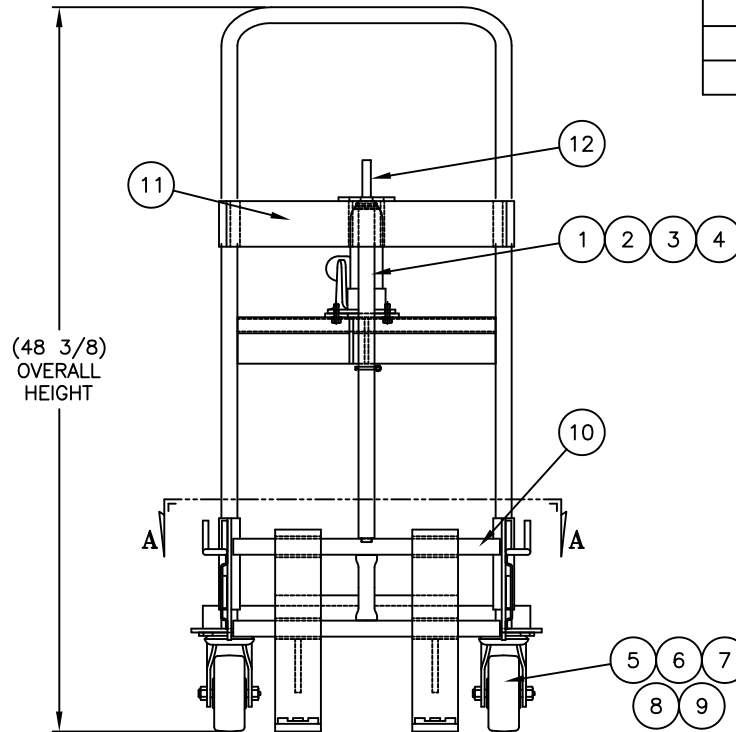
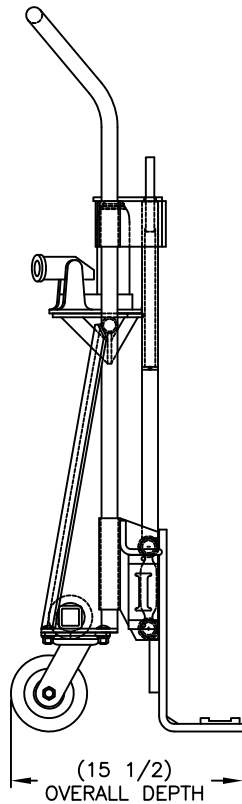

SECTION A-A

THIS DRAWING IN ALL PARTICULARS IS WESCO INDUSTRIAL PRODUCTS, LLC PROPERTY. ALL RIGHTS OF DESIGN, INVENTION OR USE OF ARE RESERVED.

PRINT ISSUED

APR 2, 2018

WESCO MANUFACTURING  
ENGINEERING DEPARTMENT

REV. ECH & DATE	REVISIONS		APP.	
	<b>WESCO INDUSTRIAL PRODUCTS, LLC</b>			
	PART NAME		DRAWING: PS 7-25-00	
	RNR-2		CHECKED:	
	TOLERANCE UNLESS OTHERWISE SPECIFIED		APP. ENGR.	
FRACTION	3 PLACE DECIMAL	2 PLACE DECIMAL	SCALE:	
± 1/64	± .005	± .01	C-260086	
ANGULAR ± 1-1/2°		SHEET 1 OF 1		REV
BREAK ALL SHARP EDGES AND REMOVE ALL BURRS				