

240076

P/N 240076  
 Model: 40BTW  
 Capacity: 1,000 lbs  
 Weight: 67 lbs  
 Wheel: 10" x 2-1/4" Polyolefin

REPLACEMENT PARTS LIST			
1	150691	WHEEL: 10 X 2-1/4" poly	2
	108208	WASHER: FLAT 1" SAE	4
	108218	COTTER PIN 3/16 X 1.5"	2
2	108433	HANDGRIP: YELLOW 1-1/4"	2
3	150303	STRAP: W/HANDLE, ASS'Y	1
	108900	SCR: HEX HD 1/4-20 x 3	2
	108929	NUT: LOCK 1/4-20	2
4	051346	UPPER SPRING HOUSING	1
5	051347	ASS'Y: FLOATING AXLE	1
6	051356	SET: HARDWARE, AXLE	1
7	240115	SET: NOSE PAD	1
8	-	BOX	

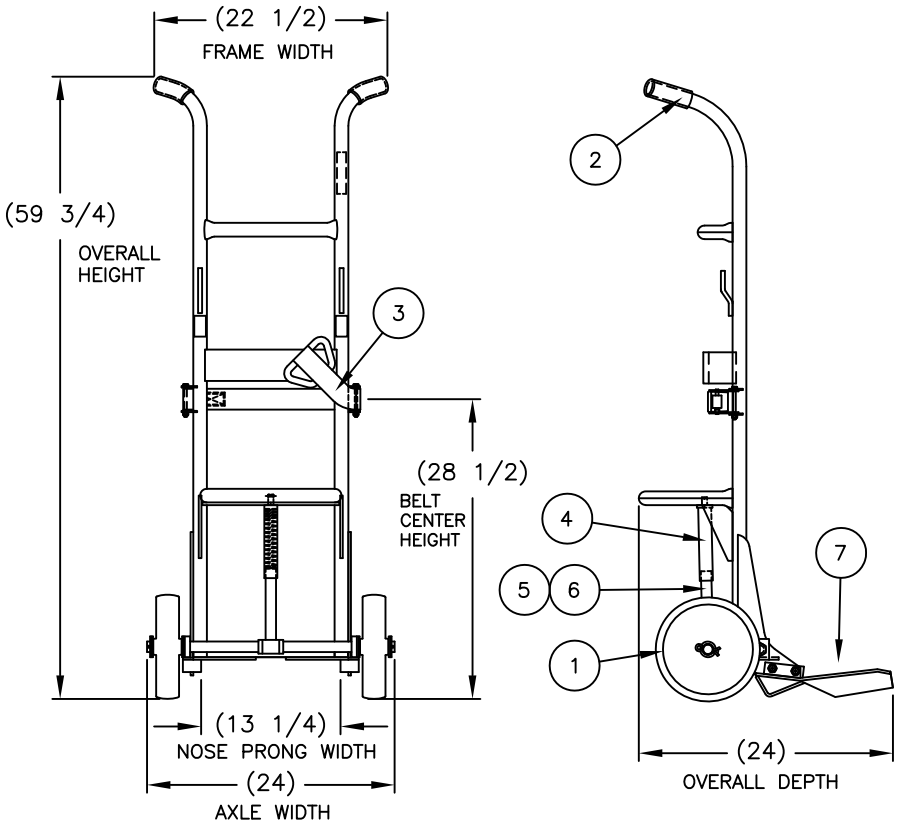

**DRUM TRUCK Features:**

- Industrial strength heavy duty 1" structural pipe frames.
- All joints double welded.
- High quality cast iron center moldon rubber wheel with 1" (ID) roller bearings.
- Polyolefin wheel is cost competitive and resistant to most environments that may damage rubber wheels.
- All trucks can be stored standing upright.
- Engineered to handle 55 gallon steel drum.
- capacity: 1,000 lbs.

**40BT/40BTW Features:**

- Handles all poly and fiber drums except overpacks (use 45BT)
- Replaceable "feet" and belt.
- Floating axle reduces effort required to break over and balance load.
- 24" depth
- With wheels resting on floor, 28.5" center of belt.

PRINT ISSUED  
 NOV. 10, 2006  
 WESCO MANUFACTURING  
 ENGINEERING DEPARTMENT

R W S  
 10-22-12  
 UPDATED  
 J

<b>WESCO INDUSTRIAL PRODUCTS INC.</b> NORTH WALES PENNA. 19454		PART NAME	<b>40BTW</b> <b>DRUM TRUCKS</b>	DRAWN: LDU 8-9-00
		TOLERANCE UNLESS OTHERWISE SPECIFIED FRACTION 3 PLACE DECIMAL 2 PLACE DECIMAL ± 1/64 ± .005 ± .01 ANGULAR ± 1-1/2" SHEET 1 OF 1 BREAK ALL SHARP EDGES AND REMOVE ALL BURRS		CHECKED:
REV. ECN & DATE REVISIONS		APP. ENGR.		SCALE: 1" = 12"
REV.		B- 240076		REV B