

240006

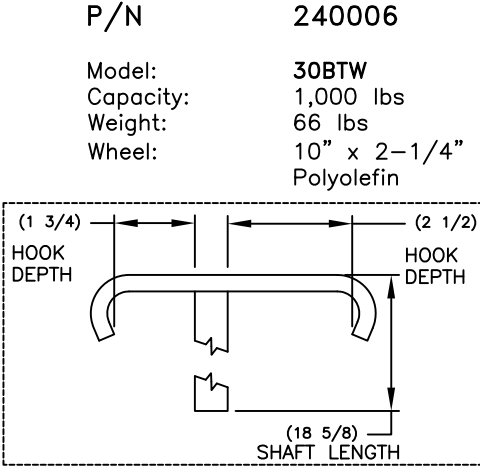
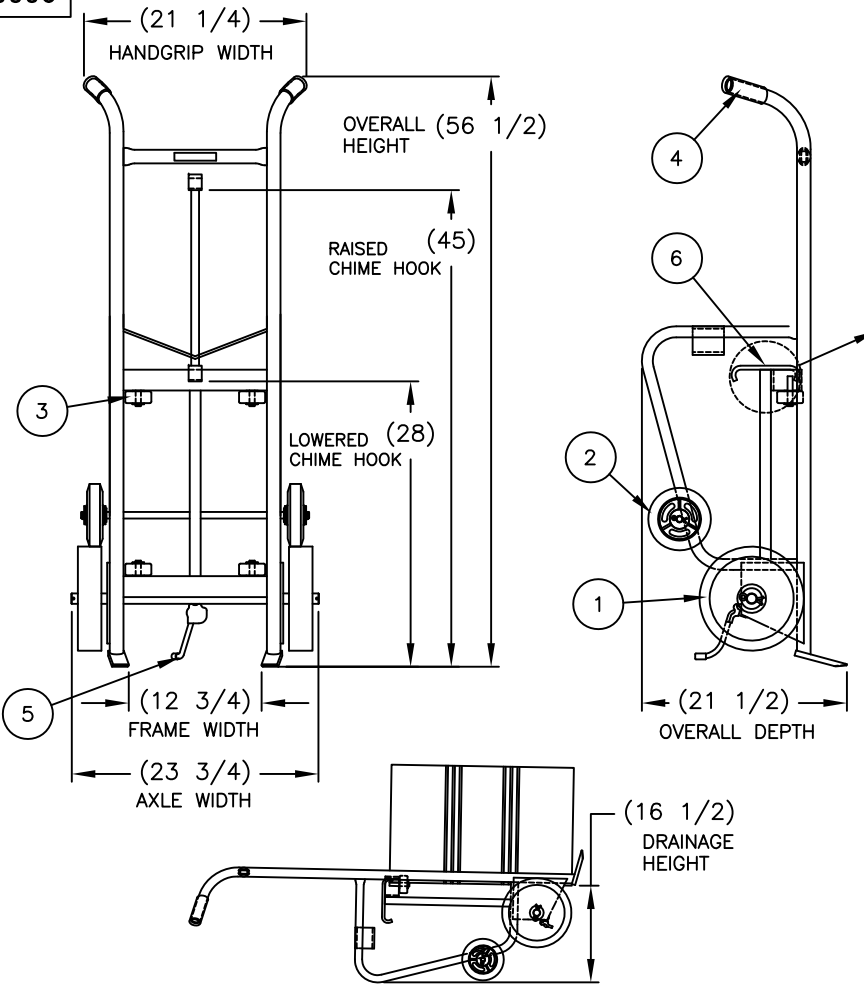

P/N 240006  
 Model: 30BTW  
 Capacity: 1,000 lbs  
 Weight: 66 lbs  
 Wheel: 10" x 2-1/4" Polyolefin

REPLACEMENT PARTS LIST			
1	150691	WHEEL: 10 X 2-1/4" poly	2
	108208	WASHER: FLAT 1" SAE	6
	108218	COTTER PIN 3/16 X 1.5"	2
2	150693	WHEEL: 6 x 1-1/2" poly	2
	100051	FLAT WASHER 5/8 SAE	4
	108219	COTTER PIN 5/32 X 1	2
3	150103	WHEEL: 2.5 X 1-1/8"	4
	108200	FLAT WASHER 1/2 SAE	4
	150867	NUT: ROUND 1/2 (PLTD)	4
4	108433	HANDGRIP: YELLOW 1-1/4"	2
5	109632	KICKSTAND (15/30BT)	1
6	050187	DRUM HOOK	1
7	-	BOX	

**DRUM TRUCK Features:**

- Industrial strength heavy duty 1" structural pipe frames.
- All joints double welded.
- High quality cast iron center moldon rubber wheel with 1" (ID) roller bearings.
- Polyolefin wheel is cost competitive and resistant to most environments that may damage rubber wheels.
- All trucks can be stored standing upright.
- Engineered to handle 55 gallon steel drum.
- capacity: 1,000 lbs.

**30BT/30BTW DELUXE Features:**

- Multi-functional drum truck allows you to move drums on four wheels and acts as a drum cradle for storage or dispensing.
- Frame clearance for dispensing into 5 gallon pails.
- Polyolefin rollers allow for easy faucet positioning of drums.
- Rear axle allows for loading and unloading of drums from pallets.
- Kickstand
- 16.5" drain height.
- with wheels resting on floor 27" to center of lowered chime hook.

PRINT ISSUED  
 NOV. 10, 2006  
 WESCO MANUFACTURING  
 ENGINEERING DEPARTMENT

REV. J	DATE 10-22-12	BY WS	APP. APP
REVISIONS			
EON & DATE			
10-22-12 UPDATED			

<b>WESCO INDUSTRIAL PRODUCTS INC.</b> NORTH WALES PENNA. 19454			
PART NAME		DRAWN: LDU 8-9-00	
<b>30BTW</b> <b>DRUM TRUCKS</b>		CHECKED:	
TOLERANCE UNLESS OTHERWISE SPECIFIED		APP. ENGR.	
FRACTION	3 PLACE DECIMAL	2 PLACE DECIMAL	SCALE: 1" = 12"
± 1/64	± .005	± .01	
ANGULAR ± 1-1/2'	SHEET 1	OF 1	B- 240006
BREAK ALL SHARP EDGES AND REMOVE ALL BURRS			
REV. J			